

# Developer's Guide to Web Applications

*Sun<sup>TM</sup> ONE Application Server*

**Version 7**

816-7150-10  
September 2002

Copyright © 2002 Sun Microsystems, Inc., 4150 Network Circle, Santa Clara, California 95054, U.S.A. All rights reserved.

THIS SOFTWARE CONTAINS CONFIDENTIAL INFORMATION AND TRADE SECRETS OF SUN MICROSYSTEMS, INC. USE, DISCLOSURE OR REPRODUCTION IS PROHIBITED WITHOUT THE PRIOR EXPRESS WRITTEN PERMISSION OF SUN MICROSYSTEMS, INC. U.S. Government Rights - Commercial software. Government users are subject to the Sun Microsystems, Inc. standard license agreement and applicable provisions of the FAR and its supplements. Use is subject to license terms.

This distribution may include materials developed by third parties.

Sun, Sun Microsystems, the Sun logo, Java and the Sun ONE logo are trademarks or registered trademarks of Sun Microsystems, Inc. in the U.S. and other countries.

UNIX is a registered trademark in the U.S. and other countries, exclusively licensed through X/Open Company, Ltd.

This product is covered and controlled by U.S. Export Control laws and may be subject to the export or import laws in other countries. Nuclear, missile, chemical biological weapons or nuclear maritime end uses or end users, whether direct or indirect, are strictly prohibited. Export or reexport to countries subject to U.S. embargo or to entities identified on U.S. export exclusion lists, including, but not limited to, the denied persons and specially designated nationals lists is strictly prohibited.

---

Copyright © 2002 Sun Microsystems, Inc., 4150 Network Circle, Santa Clara, California 95054, Etats-Unis. Tous droits réservés.

CE LOGICIEL CONTIENT DES INFORMATIONS CONFIDENTIELLES ET DES SECRETS COMMERCIAUX DE SUN MICROSYSTEMS, INC. SON UTILISATION, SA DIVULGATION ET SA REPRODUCTION SONT INTERDITES SANS L'AUTORISATION EXPRESSE, ÉCRITE ET PRÉALABLE DE SUN MICROSYSTEMS, INC. Droits du gouvernement américain, utilisateurs gouvernementaux - logiciel commercial. Les utilisateurs gouvernementaux sont soumis au contrat de licence standard de Sun Microsystems, Inc., ainsi qu'aux dispositions en vigueur de la FAR [ (Federal Acquisition Regulations) et des suppléments à celles-ci. Distribué par des licences qui en restreignent l'utilisation.

Cette distribution peut comprendre des composants développés par des tiers.

Sun, Sun Microsystems, le logo Sun, Java et le logo Sun ONE sont des marques de fabrique ou des marques déposées de Sun Microsystems, Inc. aux Etats-Unis et dans d'autres pays.

UNIX est une marque déposée aux Etats-Unis et dans d'autres pays et licenciée exclusivement par X/Open Company, Ltd.

Les produits qui font l'objet de ce manuel d'entretien et les informations qu'il contient sont régis par la législation américaine en matière de contrôle des exportations et peuvent être soumis au droit d'autres pays dans le domaine des exportations et importations. Les utilisations finales, ou utilisateurs finaux, pour des armes nucléaires, des missiles, des armes biologiques et chimiques ou du nucléaire maritime, directement ou indirectement, sont strictement interdites. Les exportations ou réexportations vers des pays sous embargo des États-Unis, ou vers des entités figurant sur les listes d'exclusion d'exportation américaines, y compris, mais de manière non exclusive, la liste de personnes qui font objet d'un ordre de ne pas participer, d'une façon directe ou indirecte, aux exportations des produits ou des services qui sont régi par la législation américaine en matière de contrôle des exportations ("U.S. Commerce Department's Table of Denial Orders") et la liste de ressortissants spécifiquement désignés ("U.S. Treasury Department of Specially Designated Nationals and Blocked Persons"), sont rigoureusement interdites.

# Contents

<b>About This Guide</b> .....	<b>9</b>
Who Should Use This Guide .....	9
Using the Documentation .....	10
How This Guide Is Organized .....	12
Documentation Conventions .....	13
General Conventions .....	13
Conventions Referring to Directories .....	15
Related Information .....	15
Product Support .....	16
<b>Chapter 1 Web Applications</b> .....	<b>17</b>
Introducing Web Applications .....	17
Servlets .....	19
JavaServer Pages .....	20
SHTML .....	21
CGI .....	21
Creating a Web Application .....	21
Deploying a Web Application .....	22
Debugging a Web Application .....	22
Internationalization Issues .....	22
The Server .....	23
Servlets .....	23
Servlet Request .....	23
Servlet Response .....	23
JSPs .....	24
Virtual Servers .....	24
Using the Administration Interface .....	25
Editing the server.xml File .....	25
Default Web Modules .....	26
Servlet and JSP Caching .....	26
Database Connection Pooling .....	27

Configuring the Web Container .....	27
Web Application Examples .....	27
<b>Chapter 2 Using Servlets .....</b>	<b>29</b>
About Servlets .....	29
Servlet Data Flow .....	30
Servlet Types .....	31
Creating Servlets .....	32
Creating the Class Declaration .....	33
Overriding Methods .....	33
Overriding Initialize .....	33
Overriding Destroy .....	34
Overriding Service, Get, and Post .....	34
Accessing Parameters and Storing Data .....	36
Handling Sessions and Security .....	36
Accessing Business Logic Components .....	37
Handling Threading Issues .....	39
Delivering Client Results .....	40
Creating a Servlet Response Page .....	40
Creating a JSP Response Page .....	41
Invoking Servlets .....	42
Calling a Servlet with a URL .....	42
Calling a Servlet Programmatically .....	43
Servlet Output .....	44
Using the Administration Interface .....	44
Editing the server.xml File .....	45
Caching Servlet Results .....	45
Caching Features .....	46
Default Cache Configuration .....	47
Caching Example .....	47
CacheHelper Interface .....	48
CacheKeyGenerator Interface .....	50
About the Servlet Engine .....	51
Instantiating and Removing Servlets .....	51
Request Handling .....	51
Allocating Servlet Engine Resources .....	52
<b>Chapter 3 Using JavaServer Pages .....</b>	<b>53</b>
Introducing JSPs .....	53
Creating JSPs .....	54
Designing for Ease of Maintenance .....	55
Designing for Portability .....	55

Handling Exceptions .....	55
JSP Tag Libraries and Standard Portable Tags .....	55
JSP Caching .....	56
cache .....	56
flush .....	58
Compiling JSPs: The Command-Line Compiler .....	59
Debugging JSPs .....	62
<b>Chapter 4 Creating and Managing User Sessions .....</b>	<b>63</b>
Introducing Sessions .....	63
Sessions and Cookies .....	64
Sessions and URL Rewriting .....	64
Sessions and Security .....	64
How to Use Sessions .....	65
Creating or Accessing a Session .....	65
Examining Session Properties .....	66
Binding Data to a Session .....	68
Invalidating a Session .....	68
Session Managers .....	69
StandardManager .....	70
Enabling StandardManager .....	70
Manager Properties for StandardManager .....	70
PersistentManager .....	71
Enabling PersistentManager .....	71
Manager Properties for PersistentManager .....	72
Store Properties for PersistentManager .....	72
<b>Chapter 5 Securing Web Applications .....</b>	<b>75</b>
User Authentication by Servlets .....	75
HTTP Basic Authentication .....	76
SSL Mutual Authentication .....	76
Form-Based Login .....	77
User Authentication for Single Sign-on .....	77
User Authorization by Servlets .....	79
Defining Roles .....	79
Defining Servlet Authorization Constraints .....	80
Fetching the Client Certificate .....	80
Security for SHTML and CGI .....	81
<b>Chapter 6 Assembling and Deploying Web Modules .....</b>	<b>83</b>
Web Application Structure .....	84
Creating Web Deployment Descriptors .....	85

Deploying Web Applications .....	86
Using the Command Line .....	86
Using the Administration Interface .....	87
Using Sun ONE Studio .....	88
Dynamic Reloading of Web Applications .....	88
The sun-web-app_2_3-0.dtd File .....	89
Subelements .....	90
Data .....	90
Attributes .....	91
Elements in the sun-web.xml File .....	91
General Elements .....	92
sun-web-app .....	92
property .....	94
description .....	95
Security Elements .....	95
security-role-mapping .....	95
servlet .....	96
servlet-name .....	96
role-name .....	96
principal-name .....	97
group-name .....	97
Session Elements .....	97
session-config .....	98
session-manager .....	98
manager-properties .....	99
store-properties .....	100
session-properties .....	101
cookie-properties .....	102
Reference Elements .....	103
resource-env-ref .....	104
resource-env-ref-name .....	104
resource-ref .....	105
res-ref-name .....	105
default-resource-principal .....	106
name .....	106
password .....	106
ejb-ref .....	107
ejb-ref-name .....	107
jndi-name .....	107
Caching Elements .....	108
cache .....	108
cache-helper .....	111
default-helper .....	111

cache-mapping .....	112
url-pattern .....	114
cache-helper-ref .....	114
timeout .....	114
refresh-field .....	115
http-method .....	115
key-field .....	116
constraint-field .....	116
value .....	117
Classloader Elements .....	118
class-loader .....	118
JSP Elements .....	119
jsp-config .....	119
Internationalization Elements .....	121
locale-charset-info .....	121
locale-charset-map .....	122
parameter-encoding .....	123
Sample Web Module XML Files .....	124
Sample web.xml File .....	124
Sample sun-web.xml File .....	130
<b>Chapter 7 Using Server-Parsed HTML .....</b>	<b>131</b>
Server-Side HTML and J2EE Web Applications .....	131
Enabling Server-Side HTML .....	132
Using Server-Side HTML Commands .....	133
config .....	134
include .....	134
echo .....	135
fsize .....	135
flastmod .....	135
exec .....	135
Environment Variables in Server-Side HTML Commands .....	136
Embedding Servlets .....	136
Time Formats .....	137
<b>Chapter 8 Using CGI .....</b>	<b>139</b>
CGI and J2EE Web Applications .....	140
Enabling CGI .....	140
Specifying CGI Directories .....	140
Specifying CGI File Extensions .....	142
Creating Custom Execution Environments for CGI Programs (UNIX only) .....	143
Specifying a Unique CGI Directory and UNIX User and Group for a Virtual Server .....	145

Specifying a Chroot Directory for a Virtual Server .....	146
Adding CGI Programs to the Server .....	149
Setting the Priority of a CGI Program .....	149
Windows CGI Programs .....	150
Overview of Windows CGI Programs .....	150
Specifying a Windows CGI Directory .....	151
Specifying Windows CGI as a File Type .....	152
Shell CGI Programs for Windows .....	152
Overview of Shell CGI Programs for Windows .....	153
Specifying a Shell CGI Directory (Windows) .....	153
Specifying Shell CGI as a File Type (Windows) .....	155
The Query Handler .....	156
Perl CGI Programs .....	157
Global CGI Settings .....	157
CGI Variables .....	158
<b>Index .....</b>	<b>161</b>



# About This Guide

This guide describes how to create and run Java 2 Platform, Enterprise Edition (J2EE) applications that follow the new open Java standards model for Servlets and JavaServer Pages (JSPs) on the Sun™ Open Net Environment (Sun ONE) Application Server 7. In addition to describing programming concepts and tasks, this guide offers implementation tips and reference material.

This preface contains information about the following topics:

- Who Should Use This Guide
- Using the Documentation
- How This Guide Is Organized
- Documentation Conventions
- Related Information
- Product Support

## Who Should Use This Guide

The intended audience for this guide is the person who develops, assembles, and deploys web applications (servlets and JSPs) in a corporate enterprise.

This guide assumes you are familiar with the following topics:

- J2EE specification
- HTML
- Java programming
- Java APIs as defined in servlet, JSP, EJB, and JDBC specifications

- Structured database query languages such as SQL
- Relational database concepts
- Software development processes, including debugging and source code control

## Using the Documentation

The Sun ONE Application Server manuals are available as online files in Portable Document Format (PDF) and Hypertext Markup Language (HTML) formats, at:

<http://docs.sun.com/>

The following table lists tasks and concepts described in the Sun ONE Application Server manuals. The left column lists the tasks and concepts, and the right column lists the corresponding manuals.

### Sun ONE Application Server Documentation Roadmap

<b>For information about</b>	<b>See the following</b>
Late-breaking information about the software and the documentation	<i>Release Notes</i>
Supported platforms and environments	<i>Platform Summary</i>
Introduction to the application server, including new features, evaluation installation information, and architectural overview.	<i>Getting Started Guide</i>
Installing Sun ONE Application Server and its various components (sample applications, Administration interface, Sun ONE Message Queue).	<i>Installation Guide</i>
Creating and implementing J2EE applications that follow the open Java standards model on the Sun ONE Application Server 7. Includes general information about application design, developer tools, security, assembly, deployment, debugging, and creating lifecycle modules.	<i>Developer's Guide</i>
Creating and implementing J2EE applications that follow the open Java standards model for web applications on the Sun ONE Application Server 7. Discusses web application programming concepts and tasks, and provides sample code, implementation tips, and reference material.	<i>Developer's Guide to Web Applications</i>

Sun ONE Application Server Documentation Roadmap (*Continued*)

<b>For information about</b>	<b>See the following</b>
Creating and implementing J2EE applications that follow the open Java standards model for enterprise beans on the Sun ONE Application Server 7. Discusses EJB programming concepts and tasks, and provides sample code, implementation tips, and reference material.	<i>Developer's Guide to Enterprise JavaBeans Technology</i>
Creating clients that access J2EE applications on the Sun ONE Application Server 7	<i>Developer's Guide to Clients</i>
Creating web services	<i>Developer's Guide to Web Services</i>
J2EE features such as JDBC, JNDI, JTS, JMS, JavaMail, resources, and connectors	<i>Developer's Guide to J2EE Features and Services</i>
Creating custom NSAPI plugins	<i>Developer's Guide to NSAPI</i>
Performing the following administration tasks:	<i>Administrator's Guide</i>
<ul style="list-style-type: none"> <li>• Using the Administration interface and the command line interface</li> <li>• Configuring server preferences</li> <li>• Using administrative domains</li> <li>• Using server instances</li> <li>• Monitoring and logging server activity</li> <li>• Configuring the web server plugin</li> <li>• Configuring the Java Messaging Service</li> <li>• Using J2EE features</li> <li>• Configuring support for CORBA-based clients</li> <li>• Configuring database connectivity</li> <li>• Configuring transaction management</li> <li>• Configuring the web container</li> <li>• Deploying applications</li> <li>• Managing virtual servers</li> </ul>	
Editing server configuration files	<i>Administrator's Configuration File Reference</i>

Sun ONE Application Server Documentation Roadmap (*Continued*)

<b>For information about</b>	<b>See the following</b>
Configuring and administering security for the Sun ONE Application Server 7 operational environment. Includes information on general security, certificates, and SSL/TLS encryption. HTTP server-based security is also addressed.	<i>Administrator's Guide to Security</i>
Configuring and administering service provider implementation for J2EE CA connectors for the Sun ONE Application Server 7. Includes information about the Administration Tool, DTDs and provides sample XML files.	<i>J2EE CA Service Provider Implementation Administrator's Guide</i>
Migrating your applications to the new Sun ONE Application Server 7 programming model from the Netscape Application Server version 2.1, including a sample migration of an Online Bank application provided with Sun ONE Application Server	<i>Migration Guide</i>
Using Sun ONE Message Queue.	The Sun ONE Message Queue documentation at:  <a href="http://docs.sun.com/?p=/coll/S1_MessageQueue_30">http://docs.sun.com/?p=/coll/S1_MessageQueue_30</a>

## How This Guide Is Organized

This guide provides a Sun ONE Application Server environment overview for designing web applications. The content is as follows:

- Chapter 1, “Web Applications”

This chapter introduces web applications and describes how they are supported in Sun ONE Application Server.

- Chapter 2, “Using Servlets”

This chapter describes how to create and use servlets.

- Chapter 3, “Using JavaServer Pages”

This chapter describes how to create and use JavaServer Pages (JSPs).

- Chapter 4, “Creating and Managing User Sessions”

This chapter describes how to create and manage a session that allows users and transaction information to persist between interactions.

- Chapter 5, “Securing Web Applications”  
This chapter describes how to write a secure web application for the Sun ONE Application Server.
  - Chapter 6, “Assembling and Deploying Web Modules”  
This chapter describes how web modules are assembled and deployed in Sun ONE Application Server.
  - Chapter 7, “Using Server-Parsed HTML”  
This chapter describes how to use server-parsed HTML with the Sun ONE Application Server.
  - Chapter 8, “Using CGI”  
This chapter describes how to use CGI with the Sun ONE Application Server.
- Finally, an *Index* is provided.

## Documentation Conventions

This section describes the types of conventions used throughout this guide:

- General Conventions
- Conventions Referring to Directories

### General Conventions

The following general conventions are used in this guide:

- **File and directory paths** are given in UNIX<sup>®</sup> format (with forward slashes separating directory names). For Windows versions, the directory paths are the same, except that backslashes are used to separate directories.
- **URLs** are given in the format:  
  
`http://server.domain/path/file.html`  
  
In these URLs, *server* is the server name where applications are run; *domain* is your Internet domain name; *path* is the server’s directory structure; and *file* is an individual filename. Italic items in URLs are placeholders.
- **Font conventions** include:

- The `monospace` font is used for sample code and code listings, API and language elements (such as function names and class names), file names, pathnames, directory names, and HTML tags.
- *Italic* type is used for code variables.
- *Italic* type is also used for book titles, emphasis, variables and placeholders, and words used in the literal sense.
- **Bold** type is used as either a paragraph lead-in or to indicate words used in the literal sense.
- **Installation root directories** for most platforms are indicated by *install\_dir* in this document. Exceptions are noted in “Conventions Referring to Directories” on page 15.

By default, the location of *install\_dir* on **most** platforms is:

- Solaris 8 non-package-based Evaluation installations:

*user's home directory/sun/appserver7*

- Solaris unbundled, non-evaluation installations:

*/opt/SUNWappserver7*

- Windows, all installations:

*C:\Sun\AppServer7*

For the platforms listed above, *default\_config\_dir* and *install\_config\_dir* are identical to *install\_dir*. See “Conventions Referring to Directories” on page 15 for exceptions and additional information.

- **Instance root directories** are indicated by *instance\_dir* in this document, which is an abbreviation for the following:  
*default\_config\_dir/domains/domain/instance*
- **UNIX-specific descriptions** throughout this manual apply to the Linux operating system as well, except where Linux is specifically mentioned.

---

**NOTE** Forte for Java 4.0 has been renamed to Sun ONE Studio 4 throughout this manual.

---

## Conventions Referring to Directories

By default, when using the Solaris 8 and 9 package-based installation and the Solaris 9 bundled installation, the application server files are spread across several root directories. These directories are described in this section.

- **For Solaris 9 bundled installations**, this guide uses the following document conventions to correspond to the various default installation directories provided:
  - *install\_dir* refers to `/usr/appserver/`, which contains the static portion of the installation image. All utilities, executables, and libraries that make up the application server reside in this location.
  - *default\_config\_dir* refers to `/var/appserver/domains`, which is the default location for any domains that are created.
  - *install\_config\_dir* refers to `/etc/appserver/config`, which contains installation-wide configuration information such as licenses and the master list of administrative domains configured for this installation.
- **For Solaris 8 and 9 package-based, non-evaluation, unbundled installations**, this guide uses the following document conventions to correspond to the various default installation directories provided:
  - *install\_dir* refers to `/opt/SUNWappserver7`, which contains the static portion of the installation image. All utilities, executables, and libraries that make up the application server reside in this location.
  - *default\_config\_dir* refers to `/var/opt/SUNWappserver7/domains` which is the default location for any domains that are created.
  - *install\_config\_dir* refers to `/etc/opt/SUNWappserver7/config`, which contains installation-wide configuration information such as licenses and the master list of administrative domains configured for this installation.

## Related Information

You can find a directory of URLs for the official specifications at [install\\_dir/docs/index.htm](install_dir/docs/index.htm). Additionally, we recommend the following resources:

### **Programming with Servlets and JSPs:**

*Java Servlet Programming*, by Jason Hunter, O'Reilly Publishing

*Java Threads, 2nd Edition*, by Scott Oaks & Henry Wong, O'Reilly Publishing

### **Programming with JDBC:**

*Database Programming with JDBC and Java*, by George Reese, O'Reilly Publishing

*JDBC Database Access With Java: A Tutorial and Annotated Reference (Java Series)*, by Graham Hamilton, Rick Cattell, & Maydene Fisher

## Product Support

If you have problems with your system, contact customer support using one of the following mechanisms:

- The online support web site at:  
<http://www.sun.com/supporttraining/>
- The telephone dispatch number associated with your maintenance contract

Please have the following information available prior to contacting support. This helps to ensure that our support staff can best assist you in resolving problems:

- Description of the problem, including the situation where the problem occurs and its impact on your operation
- Machine type, operating system version, and product version, including any patches and other software that might be affecting the problem
- Detailed steps on the methods you have used to reproduce the problem
- Any error logs or core dumps



# Web Applications

This chapter describes how web applications are supported in Sun ONE Application Server, and includes the following sections:

- Introducing Web Applications
- Creating a Web Application
- Deploying a Web Application
- Debugging a Web Application
- Internationalization Issues
- Virtual Servers
- Default Web Modules
- Servlet and JSP Caching
- Database Connection Pooling
- Configuring the Web Container
- Web Application Examples

## Introducing Web Applications

Sun ONE Application Server 7 supports the Servlet 2.3 API specification, which allows servlets and JSPs to be included in web applications.

A web application is a collection of servlets, JavaServer Pages, HTML documents, and other web resources which might include image files, compressed archives, and other data. A web application may be packaged into an archive (a WAR file) or exist in an open directory structure.

The following figure illustrates details of the J2EE environment. Web applications are in the presentation layer. Two web applications are running in the web container: one of them is part of a full application that includes EJB modules and connectors, while the other is an individually deployed web module.

Web applications in the J2EE environment

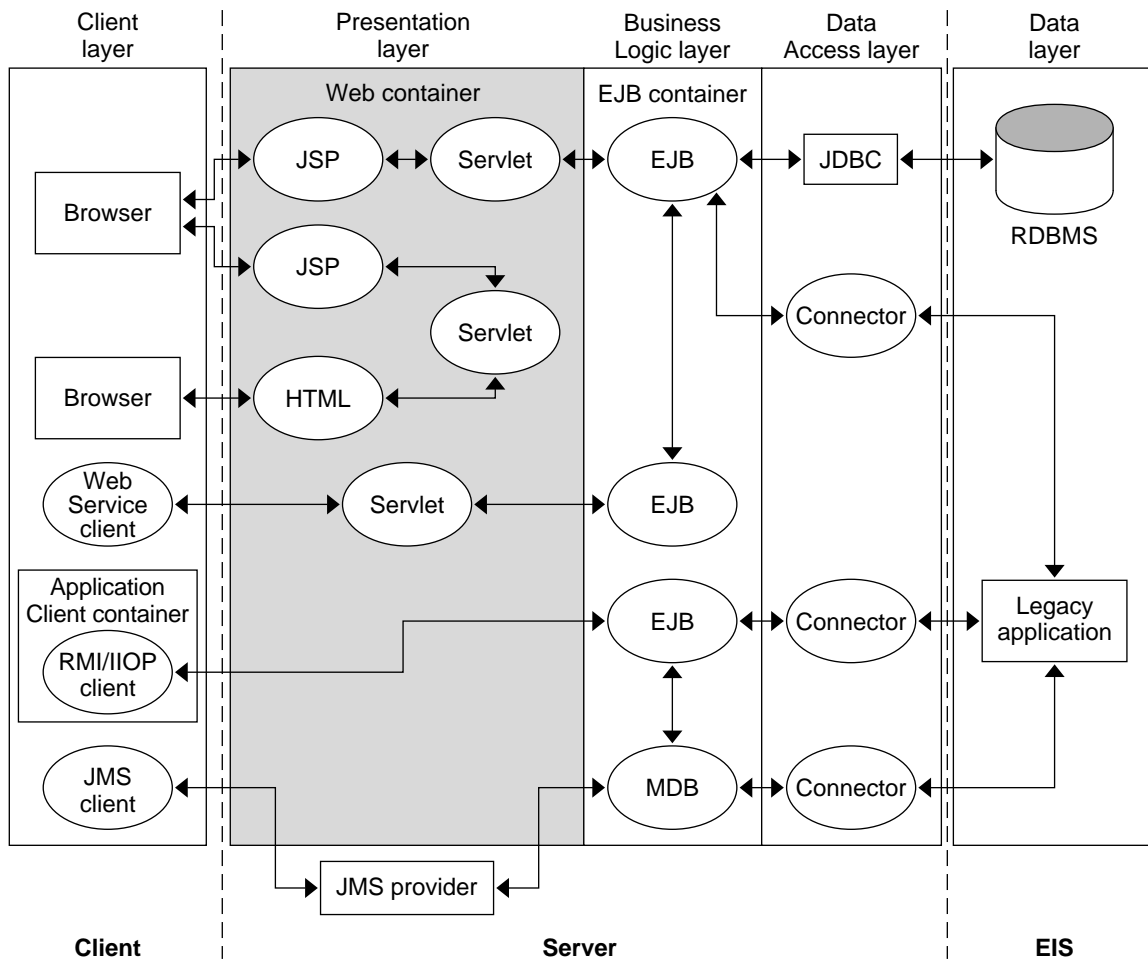

In addition, Sun ONE Application Server 7 supports SHTML and CGI, which are non-J2EE application components.

This section includes summaries of the following topics:

- Servlets
- JavaServer Pages
- SHTML
- CGI

## Servlets

Java servlets are server-side Java programs that application servers can run to generate content in response to a client request. Servlets can be thought of as applets that run on the server side without a user interface. Servlets are invoked through URL invocation or by other servlets.

Sun ONE Application Server 7 supports the Java Servlet Specification version 2.3.

---

**NOTE** Servlet API version 2.3 is fully backward compatible with versions 2.1 and 2.2, so all existing servlets will continue to work without modification or recompilation.

---

To develop servlets, use Sun Microsystems' Java Servlet API. For information about using the Java Servlet API, see the documentation provided by Sun Microsystems at:

<http://java.sun.com/products/servlet/index.html>

For information about developing servlets in Sun ONE Application Server, see Chapter 2, "Using Servlets."

# JavaServer Pages

Sun ONE Application Server 7 supports JavaServer Pages (JSP) Specification version 1.2.

A JSP is a page, much like an HTML page, that can be viewed in a web browser. However, in addition to HTML tags, it can include a set of JSP tags and directives intermixed with Java code that extend the ability of the web page designer to incorporate dynamic content in a page. These additional features provide functionality such as displaying property values and using simple conditionals.

One of the main benefits of JSPs is that they are like HTML pages. The web page designer simply writes a page that uses HTML and JSP tags and puts it on their application server. The page is compiled automatically when it is deployed. What the web page designer needs to know about Java classes and Java compilers is minimal.

Sun ONE Application Server supports precompilation of JSPs, however, and this is recommended for production servers.

JSP pages can access full Java functionality in the following ways:

- by embedding Java code directly in scriptlets in the page
- by accessing Java beans
- by using server-side tags that include Java servlets

Both beans and servlets are Java classes that need to be compiled, but they can be defined and compiled by a Java programmer, who then publishes the interface to the bean or the servlet. The web page designer can access a pre-compiled bean or servlet from a JSP page.

Sun ONE Application Server 7 supports JSP tag libraries and standard portable tags.

For information about creating JSPs, see Sun Microsystem's JavaServer Pages web site at:

<http://java.sun.com/products/jsp/index.html>

For information about Java Beans, see Sun Microsystem's JavaBeans web page at:

<http://java.sun.com/beans/index.html>

For information about developing JSPs in Sun ONE Application Server, see Chapter 3, "Using JavaServer Pages."

## SHTML

HTML files can contain tags that are executed on the server. In addition to supporting the standard server-side tags, or SSIs, Sun ONE Application Server 7 allows you to embed servlets and define your own server-side tags. For more information, see Chapter 7, “Using Server-Parsed HTML.”

## CGI

Common Gateway Interface (CGI) programs run on the server and generate a response to return to the requesting client. CGI programs can be written in various languages, including C, C++, Java, Perl, and as shell scripts. CGI programs are invoked through URL invocation. Sun ONE Application Server complies with the version 1.1 CGI specification. For more information, see Chapter 8, “Using CGI.”

# Creating a Web Application

To create a web application:

1. Create a directory for all the web application’s files. This is the web application’s document root.
2. Create any needed HTML files, image files, and other static content. Place these files in the document root directory or a subdirectory where they can be accessed by other parts of the application.
3. Create any needed JSP files. For more information, see Chapter 3, “Using JavaServer Pages.”
4. Create any needed servlets. For more information, see Chapter 2, “Using Servlets.”
5. Compile the servlets. For details about precompiling JSPs, see “Compiling JSPs: The Command-Line Compiler,” on page 59.
6. Organize the web application as described in “Web Application Structure,” on page 84.
7. Create the deployment descriptor files. For more information, see Chapter 6, “Assembling and Deploying Web Modules.”

8. Package the web application in a WAR file if desired. This is optional. For example:

```
jar -cvf module_name.war *
```

9. Deploy the web application. For more information, see Chapter 6, “Assembling and Deploying Web Modules.”

You can create a web application by hand, or you can use Sun ONE Studio 4. For more information about Sun ONE Studio, see the *Sun ONE Studio 4, Enterprise Edition Tutorial*.

## Deploying a Web Application

Web application deployment descriptor files are created by the Sun ONE Application Server Administration interface during deployment. You can also create these by hand. These descriptor files are packaged within Web Application aRchive (.war) files. They contain metadata, plus information that identifies the servlet or JSP and establishes its application role. For more information about these descriptor files, see Chapter 6, “Assembling and Deploying Web Modules.”

## Debugging a Web Application

For information about debugging applications, see the *Sun ONE Application Server Developer's Guide*.

## Internationalization Issues

This section covers internationalization as it applies to the following:

- The Server
- Servlets
- JSPs

## The Server

To set the default locale of the entire Sun ONE Application Server, which determines the locale of the Administration interface, the logs, and so on, do one of the following:

- Go to the server instance page of the Administration interface, click on the Advanced tab, type a value in the Locale field, click on the Save button, click on the General tab, and select the Apply Changes button.
- Set the `locale` attribute of the `server` element in the `server.xml` file, then restart the server. For more information about this file, see the *Sun ONE Application Server Administrator's Configuration File Reference*.

## Servlets

This section explains how the Sun ONE Application Server determines the character encoding for the servlet request and the servlet response.

For encodings you can use, see:

<http://java.sun.com/j2se/1.4/docs/guide/intl/encoding.doc.html>

### Servlet Request

When processing a servlet request, the server uses the following order of precedence, first to last, to determine the request character encoding:

- The `setCharacterEncoding()` method.
- A hidden field in the form, specified by the `parameter-encoding` element in the `sun-web.xml` file. For more information, see “parameter-encoding,” on page 123.
- The character encoding set in the `locale-charset-info` element in the `sun-web.xml` file. For more information about this element, see “Internationalization Elements,” on page 121.
- The default, which is ISO-8859-1.

### Servlet Response

When processing a servlet response, the server uses the following order of precedence, first to last, to determine the response character encoding:

- The `setContentType()` method.

- The `setLocale()` method.
- The default, which is ISO-8859-1.

## JSPs

For encodings you can use, see:

<http://java.sun.com/j2se/1.4/docs/guide/intl/encoding.doc.html>

To set the character encoding of a JSP, use the `page` directive. For example:

```
<%@ page contentType="text/html; charset=Shift_JIS" %>
```

The `contentType` attribute defines the following:

- The character encoding for the JSP page.
- The character encoding for the response of the JSP page.
- The MIME type for the response of the JSP page.

The default value is `text/html; charset=ISO-8859-1`.

When processing a JSP page, the server uses the following order of precedence, first to last, to determine the character encoding:

- The `page` directive and `contentType` attribute of JSP file.
- The default, which is ISO-8859-1.

Some JSP pages can deliver content using different content types and character encodings depending on the request time input. Dynamic setting of content type relies on an underlying invocation of `response.setContentType()`. This method can be invoked as long as no content has been sent to the response stream.

## Virtual Servers

A virtual server, also called a virtual host, is a virtual web server that serves content targeted for a specific URL. Multiple virtual servers may serve content using the same or different host names, port numbers, or IP addresses. The HTTP service can direct incoming web requests to different virtual servers based on the URL.



When you first install Sun ONE Application Server, a default virtual server is created. (You can also assign a default virtual server to each new HTTP listener you create. For details, see the *Sun ONE Application Server Administrator's Guide*.)

Web applications and J2EE applications containing web components can be assigned to virtual servers. You can assign virtual servers in either of these ways:

- Using the Administration Interface
- Editing the `server.xml` File

## Using the Administration Interface

You can assign a virtual server to a web module during deployment as described in “Deploying Web Applications,” on page 86.

To use the Administration interface to configure a default web module for a virtual server:

1. Deploy the web application or J2EE application as described in “Deploying Web Applications,” on page 86.
2. Open the HTTP Server component under your server instance.
3. Open the Virtual Servers component under the HTTP Server component.
4. Select the virtual server to which you want to assign the web application.
5. Select the web module from the Default Web Module drop-down list.
6. Select the Save button.
7. Go to the server instance page and select the Apply Changes button.

For more information, see “Default Web Modules,” on page 26.

## Editing the `server.xml` File

When a web module is deployed as part of an application, a `j2ee-application` element is created for it in `server.xml` during deployment. When a web module is deployed as an individual module, a `web-module` element is created for it in `server.xml` during deployment. The `j2ee-application` and `web-module` elements both have a `virtual-servers` attribute, which specifies a list of virtual server IDs. The `virtual-servers` attribute is empty by default, which means that the web application is assigned to all virtual servers.

Each `virtual-server` element in `server.xml` has a `default-web-module` attribute, which allows you to configure a default web module for each virtual server. A default web module for the default virtual server is provided at installation. For more information, see “Default Web Modules,” on page 26.

For more information about `server.xml` and virtual servers, see the *Sun ONE Application Server Administrator's Configuration File Reference*.

## Default Web Modules

You can assign a default web module to the default virtual server and to each new virtual server you create. For details, see “Virtual Servers,” on page 24. To access the default web module for a virtual server, point your browser to the URL for the virtual server, but do not supply a context root. For example:

```
http://myvserver:3184/
```

If you do not assign a default web module to a virtual server, the virtual server serves HTML or JSP content from its document root, which is usually `instance_dir/docroot`. To access this HTML or JSP content, point your browser to the URL for the virtual server, do not supply a context root, but specify the target file. For example:

```
http://myvserver:3184/hellothere.jsp
```

## Servlet and JSP Caching

The Sun ONE Application Server has the ability to cache servlet or JSP results in order to make subsequent calls to the same servlet or JSP faster. The Sun ONE Application Server caches the request results for a specific amount of time. In this way, if another data call occurs the Sun ONE Application Server can return the cached data instead of performing the operation again. For example, if your servlet returns a stock quote that updates every 5 minutes, you set the cache to expire after 300 seconds.

For more information about response caching as it pertains to servlets, see “Caching Servlet Results,” on page 45. For more information about JSP caching, see “JSP Caching,” on page 56.

# Database Connection Pooling

Database connection pooling enhances the performance of servlet or JSP database interactions. There are several JDBC 2.0 compatible drivers that support connection pooling, for example Pointbase (provided with Sun ONE Application Server except for Solaris 9 bundled installations), Oracle 8i update, and CloudScape 3.0. For more information about JDBC, see the *Sun ONE Application Server Developer's Guide to J2EE Features and Services*.

## Configuring the Web Container

You can configure logging in the web container for the entire server in these ways:

- By using the Administration interface; see the *Sun ONE Application Server Administrator's Guide*.
- By editing the `server.xml` file; see the *Sun ONE Application Server Administrator's Configuration File Reference*.

## Web Application Examples

Sample web applications that you can examine and deploy are included in Sun ONE Application Server, in the `install_dir/samples/webapps` directory. Each sample has its own documentation.



# Using Servlets

This chapter describes how to create effective servlets to control application interactions running on a Sun ONE Application Server, including standard servlets. In addition, this chapter describes the Sun ONE Application Server features to use to augment the standards.

This chapter contains the following sections:

- About Servlets
- Creating Servlets
- Invoking Servlets
- Servlet Output
- Caching Servlet Results
- About the Servlet Engine

## About Servlets

Servlets, like applets, are reusable Java applications. However, servlets run on an application server or web server rather than in a web browser.

Servlets supported by the Sun ONE Application Server are based on the Java Servlet Specification v2.3. All relevant specifications are accessible from *install\_dir/docs/index.htm*, where *install\_dir* is the directory where the Sun ONE Application Server is installed.

Servlets are used for an application's presentation logic. A servlet acts as an application's central dispatcher by processing form input, invoking business logic components encapsulated in EJB components, and formatting web page output using JSPs. Servlets control the application flow from one user interaction to the next by generating content in response to user requests.

The fundamental characteristics are:

- Servlets are created and managed at runtime by the Sun ONE Application Server servlet engine.
- Servlets operate on input data that is encapsulated in a `request` object.
- Servlets respond to a query with data encapsulated in a `response` object.
- Servlets call EJB components to perform business logic functions.
- Servlets call JSPs to perform page layout functions.
- Servlets are extensible; use the APIs provided with the Sun ONE Application Server to add functionality.
- Servlets provide user session information persistence between interactions.
- Servlets can be part of an application or they can reside discretely on the application server so they are available to multiple applications.
- Servlets can be dynamically reloaded while the server is running.
- Servlets are addressable with URLs; buttons on an application's pages often point to servlets.
- Servlets can call other servlets.

## Servlet Data Flow

When a user clicks a Submit button, information entered in a display page is sent to a servlet. The servlet processes the incoming data and orchestrates a response by generating content, often through business logic components, which are EJB components. Once the content is generated, the servlet creates a response page, usually by forwarding the content to a JSP. The response is sent back to the client, which sets up the next user interaction.

The following illustration shows the information flow to and from the servlet, as:

1. Servlet processes the client request
2. Servlet generates content

3. Servlet creates response and either:
  - a. Sends it back directly to the client
  - or
  - b. Dispatches the task to a JSP

The servlet remains in memory, available to process another request.

### Servlet Data Flow Steps

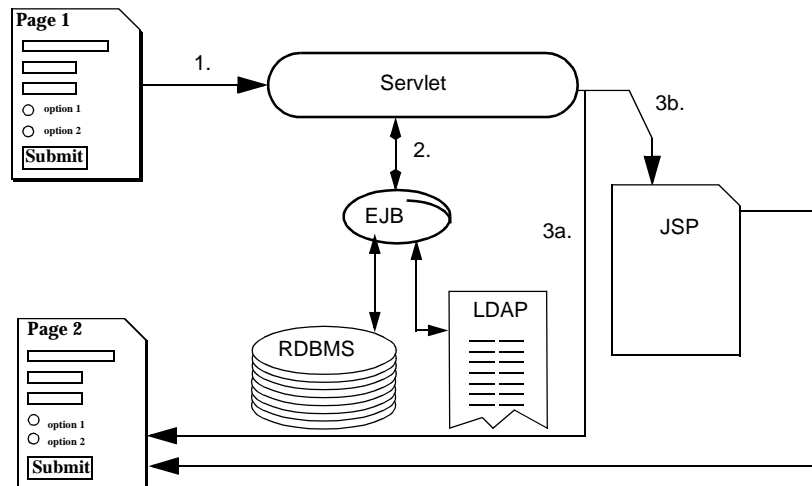

## Servlet Types

There are two main servlet types:

- Generic servlets
  - Extend `javax.servlet.GenericServlet`.
  - Are protocol independent; they contain no inherent HTTP support or any other transport protocol.

- HTTP servlets
  - Extend `javax.servlet.HttpServlet`.
  - Have built-in HTTP protocol support and are more useful in a Sun ONE Application Server environment.

For both servlet types, implement the constructor method `init()` and the destructor method `destroy()` to initialize or deallocate resources, respectively.

All servlets must implement a `service()` method, which is responsible for handling servlet requests. For generic servlets, simply override the `service` method to provide routines for handling requests. HTTP servlets provide a `service` method that automatically routes the request to another method in the servlet based on which HTTP transfer method is used. So, for HTTP servlets, override `doPost()` to process POST requests, `doGet()` to process GET requests, and so on.

## Creating Servlets

To create a servlet, perform the following tasks:

- Design the servlet into your application, or, if accessed in a generic way, design it to access no application data.
- Create a class that extends either `GenericServlet` or `HttpServlet`, overriding the appropriate methods so it handles requests.
- Use the Sun ONE Application Server Administration interface to create a web application deployment descriptor. For details, see Chapter 6, “Assembling and Deploying Web Modules.”

The rest of this section discusses the following topics:

- Creating the Class Declaration
- Overriding Methods
- Accessing Parameters and Storing Data
- Handling Sessions and Security
- Accessing Business Logic Components
- Handling Threading Issues
- Delivering Client Results



## Creating the Class Declaration

To create a servlet, write a public Java class that includes basic I/O support as well as the package `javax.servlet`. The class must extend either `GenericServlet` or `HttpServlet`. Since Sun ONE Application Server servlets exist in an HTTP environment, the latter class is recommended. If the servlet is part of a package, you must also declare the package name so the class loader can properly locate it.

The following example header shows the HTTP servlet declaration called `myServlet`:

```
import java.io.*;
import javax.servlet.*;
import javax.servlet.http.*;

public class myServlet extends HttpServlet {
    ...servlet methods...
}
```

## Overriding Methods

Next, override one or more methods to provide servlet instructions to perform its intended task. All processing by a servlet is done on a request-by-request basis and happens in the service methods, either `service()` for generic servlets or one of the `doOperation()` methods for HTTP servlets. This method accepts incoming requests, processing them according to the instructions you provide, and directs the output appropriately. You can create other methods in a servlet as well.

Business logic may involve database access to perform a transaction or passing the request to an EJB component.

### Overriding Initialize

Override the class initializer `init()` to initialize or allocate resources for the servlet instance's life, such as a counter. The `init()` method runs after the servlet is instantiated but before it accepts any requests. For more information, see the servlet API specification.

---

**NOTE** All `init()` methods must call `super.init(ServletConfig)` to set their scope. This makes the servlet's configuration object available to other servlet methods. If this call is omitted, a 500 `SC_INTERNAL_SERVER_ERROR` appears in the browser when the servlet starts up.

---

---

**NOTE** A web application is not started if any of its components, such as a filter, throws a `ServletException` during initialization. This is to ensure that if any part of the web application runs, all of it runs. It is especially important that a web application fail if security components fail.

---

The following example of the `init()` method initializes a counter by creating a public integer variable called `thisMany`:

```
public class myServlet extends HttpServlet {
    int thisMany;

    public void init (ServletConfig config) throws ServletException
    {
        super.init(config);
        thisMany = 0;
    }
}
```

Now other servlet methods can access the variable.

## Overriding Destroy

Override the class destructor `destroy()` to write log messages or to release resources that have been opened in the servlet's life cycle. Resources should be appropriately closed and dereferenced so that they are recycled or garbage collected. The `destroy()` method runs just before the servlet itself is deallocated from memory. For more information, see the servlet API specification.

For example, the `destroy()` method could write a log message like the following, based on the example for "Overriding Initialize" above:

```
out.println("myServlet was accessed " + thisMany + " times.\n");
```

## Overriding Service, Get, and Post

When a request is made, the Sun ONE Application Server hands the incoming data to the servlet engine to process the request. The request includes form data, cookies, session information, and URL name-value pairs, all in a type `HttpServletRequest` object called the request object. Client metadata is encapsulated as a type `HttpServletResponse` object called the response object. The servlet engine passes both objects as the servlet's `service()` method parameters.

The default `service()` method in an HTTP servlet routes the request to another method based on the HTTP transfer method (POST, GET, and so on). For example, HTTP POST requests are routed to the `doPost()` method, HTTP GET requests are routed to the `doGet()` method, and so on. This enables the servlet to perform different request data processing depending on the transfer method. Since the routing takes place in `service()`, there is no need to generally override `service()` in an HTTP servlet. Instead, override `doGet()`, `doPost()`, and so on, depending on the expected request type.

The automatic routing in an HTTP servlet is based simply on a call to `request.getMethod()`, which provides the HTTP transfer method. In a Sun ONE Application Server, request data is already preprocessed into a name-value list by the time the servlet sees the data, so simply overriding the `service()` method in an HTTP servlet does not lose any functionality. However, this does make the servlet less portable, since it is now dependent on preprocessed request data.

Override the `service()` method (for generic servlets) or the `doGet()` or `doPost()` methods (for HTTP servlets) to perform tasks needed to answer the request. Very often, this means accessing EJB components to perform business transactions, collating the needed information (in the request object or in a JDBC result set object), and then passing the newly generated content to a JSP for formatting and delivery back to the client.

Most operations that involve forms use either a GET or a POST operation, so for most servlets you override either `doGet()` or `doPost()`. Note that implementing both methods to provide for both input types or simply pass the request object to a central processing method, as shown in the following example:

```
public void doGet (HttpServletRequest request,
                  HttpServletResponse response)
    throws ServletException, IOException {
    doPost(request, response);
}
```

All request-by-request traffic in an HTTP servlet is handled in the appropriate `doOperation()` method, including session management, user authentication, dispatching EJB components and JSPs, and accessing Sun ONE Application Server features.

If a servlet intends to call the `RequestDispatcher` method `include()` or `forward()`, be aware the request information is no longer sent as HTTP POST, GET, and so on. In other words, if a servlet overrides `doPost()`, it may not process anything if another servlet calls it, if the calling servlet happens to receive its data through HTTP GET. For this reason, be sure to implement routines for all possible input types, as explained above. `RequestDispatcher` methods always call `service()`.

For more information, see “Calling a Servlet Programmatically,” on page 43.

---

**NOTE** Arbitrary binary data, such as uploaded files or images, can be problematic, since the web connector translates incoming data into name-value pairs by default. You can program the web connector to properly handle these kinds of data and package them correctly in the request object.

---

## Accessing Parameters and Storing Data

Incoming data is encapsulated in a request object. For HTTP servlets, the request object type is `HttpServletRequest`. For generic servlets, the request object type is `ServletRequest`. The request object contains all request parameters, including your own request values called *attributes*.

To access all incoming request parameters, use the `getParameter()` method. For example:

```
String username = request.getParameter("username");
```

Set and retrieve values in a request object using `setAttribute()` and `getAttribute()`, respectively. For example:

```
request.setAttribute("favoriteDwarf", "Dwalin");
```

This shows one way to transfer data to a JSP, since JSPs have access to the request object as an implicit bean.

## Handling Sessions and Security

From a web or application server’s perspective, a web application is a series of unrelated server hits. There is no automatic recognition if a user has visited the site before, even if their last interaction were seconds before. A session provides a context between multiple user interactions by remembering the application state. Clients identify themselves during each interaction by a cookie, or, in the case of a cookie-less browser, by placing the session identifier in the URL.

A session object can store objects, such as tabular data, information about the application’s current state, and information about the current user. Objects bound to a session are available to other components that use the same session.

For more information, see Chapter 4, “Creating and Managing User Sessions.”

After a successful login, you should direct a servlet to establish the user's identity in a standard object called a session object that holds information about the current session, including the user's login name and whatever additional information to retain. Application components can then query the session object to obtain user authentication.

To provide a secure user session for your application, see Chapter 5, "Securing Web Applications."

## Accessing Business Logic Components

In the Sun ONE Application Server programming model, you implement business logic, including database or directory transactions and complex calculations, in EJB components. A `request` object reference can be passed as an EJB parameter to perform the specified task.

Store the results from database transactions in JDBC `ResultSet` objects and pass object references to other components for formatting and delivery to the client. Also, store request object results by using the `request.setAttribute()` method, or in the session by using the `session.setAttribute()` method. Objects stored in the request object are valid only for the request length, or in other words for this particular servlet thread. Objects stored in the session persist for the session duration, which can span many user interactions.

This example shows a servlet accessing an EJB component called `ShoppingCart`. The servlet creates a cart handle by casting the user's session ID as a cart after importing the cart's remote interface. The cart is stored in the user's session.

```
import cart.ShoppingCart;

// Get the user's session and shopping cart
HttpSession session = request.getSession(true);
ShoppingCart cart =
    (ShoppingCart)session.getAttribute(session.getId());

// If the user has no cart, create a new one
if (cart == null) {
    String jndiNm = "java:comp/env/ejb/ShoppingCart";
    javax.naming.Context initCtx = null;
    Object home = null;
    try {
        initCtx = new javax.naming.InitialContext(env);
        java.util.Properties props = null;
        home = initCtx.lookup(jndiNm);
        cart = ((IShoppingCartHome) home).create();
    }
}
```

```

        session.setValue(session.getId(), cart);
    }
    catch (Exception ex) {
        .....
        .....
    }
}

```

Access EJB components from servlets by using the Java Naming Directory Interface (JNDI) to establish a handle, or proxy, to the EJB component. Next, refer to the EJB component as a regular object; overhead is managed by the bean's container.

This example shows JNDI looking up a proxy for the shopping cart:

```

String jndiNm = "java:comp/env/ejb/ShoppingCart";
javax.naming.Context initCtx;
Object home;
    try
    {
        initCtx = new javax.naming.InitialContext(env);
    }
    catch (Exception ex)
    {
        return null;
    }
    try
    {
        java.util.Properties props = null;
        home = initCtx.lookup(jndiNm);
    }
    catch(javax.naming.NameNotFoundException e)
    {
        return null;
    }
    catch(javax.naming.NamingException e)
    {
        return null;
    }
    try
    {
        IShoppingCart cart = ((IShoppingCartHome) home).create();
    }
    catch (...) {...}

```

For more information on EJB components, see the *Sun ONE Application Server Developer's Guide to Enterprise JavaBeans Technology*.

---

**NOTE** To avoid collisions with names of other enterprise resources in JNDI, and to avoid portability problems, all names in a Sun ONE Application Server application should begin with the string `java:comp/env.`

---

## Handling Threading Issues

By default, servlets are not thread-safe. The methods in a single servlet instance are usually executed numerous times simultaneously (up to the available memory limit). Each execution occurs in a different thread though only one servlet copy exists in the servlet engine.

This is efficient system resource usage, but is dangerous because of how Java manages memory. Because variables belonging to the servlet class are passed by reference, different threads can overwrite the same memory space as a side effect. To make a servlet (or a block within a servlet) thread-safe, do one of the following:

- Synchronize write access to all instance variables, as in `public synchronized void method()` (whole method) or `synchronized(this) {...}` (block only). Because synchronizing slows response time considerably, synchronize only blocks, or make sure that the blocks in the servlet do not need synchronization.

For example, this servlet has a thread-safe block in `doGet()` and a thread-safe method called `mySafeMethod()`:

```
import java.io.*;
import javax.servlet.*;
import javax.servlet.http.*;

public class myServlet extends HttpServlet {

    public void doGet (HttpServletRequest request,
                      HttpServletResponse response)
                      throws ServletException, IOException {
        //pre-processing
        synchronized (this) {
            //code in this block is thread-safe
        }
        //other processing;
    }

    public synchronized int mySafeMethod (HttpServletRequest request)
```

```

    {
        //everything that happens in this method is thread-safe
    }
}

```

- Use the `SingleThreadModel` class to create a single-threaded servlet. When a single-threaded servlet is deployed to the Sun ONE Application Server, the servlet engine creates a servlet instance pool used for incoming requests (multiple copies of the same servlet in memory). You can change the number of servlet instances in the pool by setting the `singleThreadedServletPoolSize` property in the Sun ONE Application Server specific web application deployment descriptor. For more information on the Sun ONE Application Server web application deployment descriptor, see Chapter 6, “Assembling and Deploying Web Modules.” A single-threaded servlet is slower under load because new requests must wait for a free instance in order to proceed, but this is not a problem with distributed, load-balanced applications since the load automatically shifts to a less busy process.

For example, this servlet is completely single-threaded:

```

import java.io.*;
import javax.servlet.*;
import javax.servlet.http.*;

public class myServlet extends HttpServlet
    implements SingleThreadModel {
    servlet methods...
}

```

## Delivering Client Results

The final user interaction activity is to provide a response page to the client. The response page can be delivered in two ways:

- Creating a Servlet Response Page
- Creating a JSP Response Page

### Creating a Servlet Response Page

Generate the output page within a servlet by writing to the output stream. The recommended way to do this depends on the output type.



Always specify the output MIME type using `setContentType()` before any output commences, as in this example:

```
response.setContentType("text/html");
```

For textual output, such as plain HTML, create a `PrintWriter` object and then write to it using `println`. For example:

```
PrintWriter output = response.getWriter();
output.println("Hello, World\n");
```

For binary output, write to the output stream directly by creating a `ServletOutputStream` object and then write to it using `print()`. For example:

```
ServletOutputStream output = response.getOutputStream();
output.print(binary_data);
```

## Creating a JSP Response Page

Servlets can invoke JSPs in two ways:

- The `include()` method in the `RequestDispatcher` interface calls a JSP and waits for it to return before continuing to process the interaction. The `include()` method can be called multiple times within a given servlet.

This example shows a JSP using `include()`:

```
RequestDispatcher dispatcher =
    getServletContext().getRequestDispatcher("JSP_URI");
dispatcher.include(request, response);
... //processing continues
```

- The `forward()` method in the `RequestDispatcher` interface hands the JSP interaction control. The servlet is no longer involved with the current interaction's output after invoking `forward()`, thus only one call to the `forward()` method can be made in a particular servlet.

---

**NOTE** You cannot use the `forward()` method if you have already defined a `PrintWriter` or `ServletOutputStream` object.

---

This example shows a JSP using `forward()`:

```
RequestDispatcher dispatcher =
    getServletContext().getRequestDispatcher("JSP_URI");
dispatcher.forward(request, response);
```

---

**NOTE** Identify which JSP to call by specifying a Universal Resource Identifier (URI). The path is a `String` describing a path within the `ServletContext` scope. There is also a `getRequestDispatcher()` method in the request object that takes a `String` argument indicating a complete path. For more information about this method, see the Java Servlet Specification, v2.3, section 8.

---

For more information about JSPs, see Chapter 3, “Using JavaServer Pages.”

## Invoking Servlets

You can invoke a servlet by directly addressing it from an application page with a URL or calling it programmatically from an already running servlet. See the following sections:

- Calling a Servlet with a URL
- Calling a Servlet Programmatically

### Calling a Servlet with a URL

You can call servlets by using URLs embedded as links in an application’s HTML or JSP pages. The format of these URLs is as follows:

```
http://server:port/context_root/servlet/servlet_name?name=value
```

The following table describes each URL section. The left column lists the URL elements, and the right column lists descriptions of each URL element.

URL Fields for Servlets within an Application	
URL element	Description
<i>server:port</i>	The IP address (or host name) and optional port number.  To access the default web module for a virtual server, specify only this URL section. You do not need to specify the <i>context_root</i> or <i>servlet_name</i> unless you also wish to specify name-value parameters.

URL Fields for Servlets within an Application *(Continued)*

URL element	Description
<code>context_root</code>	For an application, the context root is defined in the <code>context-root</code> element of the <code>application.xml</code> or <code>sun-application.xml</code> file. For an individually deployed web module, you specify the context root during deployment.
<code>servlet</code>	Only needed if no <code>servlet-mapping</code> is defined in the <code>web.xml</code> file.
<code>servlet_name</code>	The <code>servlet-name</code> (or <code>servlet-mapping</code> if defined) as configured in the <code>web.xml</code> file.
<code>?name=value...</code>	Optional servlet name-value parameters.

In this example, `leMort` is the host name, `MortPages` is the context root, and `calcMortgage` is the servlet name:

```
http://www.leMort.com/MortPages/servlet/calcMortgage?rate=8.0&per=360&bal=180000
```

## Calling a Servlet Programmatically

First, identify which servlet to call by specifying a URI. This is normally a path relative to the current application. For example, if your servlet is part of an application with a context root called `OfficeFrontEnd`, the URL to a servlet called `ShowSupplies` from a browser is as follows:

```
http://server:port/OfficeApp/OfficeFrontEnd/servlet/ShowSupplies?name=value
```

You can call this servlet programmatically from another servlet in one of two ways, as described below.

- To include another servlet's output, use the `include()` method from the `RequestDispatcher` interface. This method calls a servlet by its URI and waits for it to return before continuing to process the interaction. The `include()` method can be called multiple times within a given servlet.

For example:

```
RequestDispatcher dispatcher =
    getServletContext().getRequestDispatcher("/ShowSupplies");
dispatcher.include(request, response);
```

- To hand interaction control to another servlet, use the `RequestDispatcher` interface's `forward()` method with the servlet's URI as a parameter.

---

**NOTE** Forwarding a request means the original servlet is no longer involved with the current interaction output after `forward()` is invoked. Therefore, only one `forward()` call can be made in a particular servlet.

---

This example shows a servlet using `forward()`:

```
RequestDispatcher dispatcher =
    getServletContext().getRequestDispatcher("/ShowSupplies");
dispatcher.forward(request, response);
```

## Servlet Output

`ServletContext.log` messages are sent to the server log.

By default, the `System.out` and `System.err` output of servlets are sent to the server log, and during start-up server log messages are echoed to the `System.err` output. Also by default, there is no Windows-only console for the `System.err` output. You can change these defaults in these ways:

- Using the Administration Interface
- Editing the `server.xml` File

## Using the Administration Interface

Use the Administration interface as follows:

1. Click on the Logging tab of the server instance page in the Administration interface.
2. Check or uncheck these boxes:
  - Log stdout content to event log - If `true`, `System.out` output is sent to the server log.
  - Log stderr content to event log - If `true`, `System.err` output is sent to the server log.
  - Echo to stderr - If `true`, server log messages are echoed `System.err`.
  - Create console - Creates a Windows-only console for `System.err` output.

3. Click on the Save button.
4. Go to the server instance page and select the Apply Changes button.

For more information, see the *Sun ONE Application Server Administrator's Guide*.

## Editing the server.xml File

Edit the `server.xml` file as follows, then restart the server:

```
<log-service log-stdout=false
             log-stderr=false
             echo-log-messages-to-stderr=false
             create-console=true />
```

The `create-console` attribute is Windows-only. For more information about `server.xml`, see the *Sun ONE Application Server Administrator's Configuration File Reference*.

## Caching Servlet Results

The Sun ONE Application Server can cache the results of invoking a servlet, a JSP, or any URL pattern to make subsequent invocations of the same servlet, JSP, or URL pattern faster. The Sun ONE Application Server caches the request results for a specific amount of time. In this way, if another data call occurs, the Sun ONE Application Server can return the cached data instead of performing the operation again. For example, if your servlet returns a stock quote that updates every 5 minutes, you set the cache to expire after 300 seconds.

Whether to cache results and how to cache them depends on the data involved. For example, it makes no sense to cache the results of a quiz submission, because the input to the servlet is different each time. However, you could cache a high level report showing demographic data taken from quiz results that is updated once an hour.

You can define how a Sun ONE Application Server web application handles response caching by editing specific fields in the `sun-web.xml` file. In this way, you can create programmatically standard servlets that still take advantage of this valuable Sun ONE Application Server feature.

For more information about JSP caching, see “JSP Caching,” on page 56.

---

**NOTE** For information about caching static file content, see the `nsfc.conf` file, described in the *Sun ONE Application Server Administrator's Configuration File Reference*.

---

The rest of this section covers the following topics:

- Caching Features
- Default Cache Configuration
- Caching Example
- CacheHelper Interface
- CacheKeyGenerator Interface

## Caching Features

Sun ONE Application Server 7 has the following web application response caching capabilities:

- Caching is configurable based on the servlet name or the URI.
- When caching is based on the URI, this includes user specified parameters in the query string. For example, a response from `/garden/catalog?category=roses` is different from a response from `/garden/catalog?category=lilies`. These responses are stored under different keys in the cache.
- Cache size, entry timeout, and other caching behaviors are configurable.
- Entry timeout is measured from the time an entry is created or refreshed. You can override this timeout for an individual cache mapping by specifying the `cache-mapping subelement timeout`.
- You can determine caching criteria programmatically by writing a cache helper class. For example, if a servlet only knows when a back end data source was last modified, you can write a helper class to retrieve the last modified timestamp from the data source and decide whether to cache the response based on that timestamp. See “CacheHelper Interface,” on page 48.
- You can determine cache key generation programmatically by writing a cache key generator class. See “CacheKeyGenerator Interface,” on page 50.

- All non-ASCII request parameter values specified in cache key elements must be URL encoded. The caching subsystem attempts to match the raw parameter values in the request query string.
- Since newly updated classes impact what gets cached, the web container clears the cache during dynamic deployment or reloading of classes.
- The following `HttpServletRequest` request attributes are exposed:
  - `com.sun.appserv.web.cachedServletName`, the cached servlet target
  - `com.sun.appserv.web.cachedURLPattern`, the URL pattern being cached

## Default Cache Configuration

If you enable caching but do not provide any special configuration for a servlet or JSP, the default cache configuration is as follows:

- The default cache timeout is 30 seconds.
- Only the HTTP GET method is eligible for caching.
- HTTP requests with cookies or sessions automatically disable caching.
- No special consideration is given to `Pragma:`, `Cache-control:`, or `Vary:` headers.
- The default key consists of the Servlet Path (minus `pathInfo` and the query string).
- A “least recently used” list is maintained to evict cache entries if the maximum cache size is exceeded.
- Key generation concatenates the servlet path with key field values, if any are specified.

## Caching Example

Here is an example cache element in the `sun-web.xml` file:

```
<cache max-capacity="8192" timeout="60">
  <cache-helper name="myHelper" class-name="MyCacheHelper" />
  <cache-mapping>
    <servlet-name>myservlet</servlet name
    <timeout name="timefield">120</timeout>
    <http-method>GET</http-method>
```

```

    <http-method>POST</http-method>
</cache-mapping>
<cache-mapping>
  <url-pattern> /catalog/* </url-pattern>
  <!-- cache the best selling category; cache the responses to
    -- this resource only when the given parameters exist. cache
    -- only when the catalog parameter has 'lilies' or 'roses'
    -- but no other catalog varieties:
    -- /orchard/catalog?best&category='lilies'
    -- /orchard/catalog?best&category='roses'
    -- but not the result of
    -- /orchard/catalog?best&category='wild'
  -->
  <constraint-field name='best' scope='request.parameter' />
  <constraint-field name='category' scope='request.parameter'>
    <value> roses </value>
    <value> lilies </value>
  </constraint-field>
  <!-- Specify that a particular field is of given range but the
    -- field doesn't need to be present in all the requests -->
  <constraint-field name='SKUnum' scope='request.parameter'>
    <value match-expr='in-range'> 1000 - 2000 </value>
  </constraint-field>
  <!-- cache when the category matches with any value other than
    -- a specific value -->
  <constraint-field name="category" scope="request.parameter">
    <value match-expr="equals" cache-on-match-failure="true">bogus</value>
  </constraint-field>
</cache-mapping>
<cache-mapping>
  <servlet-name> InfoServlet </servlet name>
  <cache-helper-ref>myHelper</cache-helper-ref>
</cache-mapping>
</cache>

```

For more information about the `sun-web.xml` caching settings, see “Caching Elements,” on page 108.

## CacheHelper Interface

Here is the `CacheHelper` interface:

```

package com.sun.appserv.web.cache;

import java.util.Map

```



```

import javax.servlet.ServletContext;
import javax.servlet.http.HttpServletRequest;

/** CacheHelper interface is an user-extensible interface to customize:
 * a) the key generation b) whether to cache the response.
 */
public interface CacheHelper {

    // name of request attributes
    public static final String ATTR_CACHE_MAPPED_SERVLET_NAME =
        "com.sun.appserv.web.cachedServletName";
    public static final String ATTR_CACHE_MAPPED_URL_PATTERN =
        "com.sun.appserv.web.cachedURLPattern";

    public static final int TIMEOUT_VALUE_NOT_SET = -2;

    /** initialize the helper
     * @param context the web application context this helper belongs to
     * @exception Exception if a startup error occurs
     */
    public void init(ServletContext context, Map props) throws Exception;

    /** getCacheKey: generate the key to be used to cache this request
     * @param request incoming <code>HttpServletRequest</code> object
     * @returns the generated key for this requested cacheable resource.
     */
    public String getCacheKey(HttpServletRequest request);

    /** isCacheable: is the response to given request cacheable?
     * @param request incoming <code>HttpServletRequest</code> object
     * @returns <code>true</code> if the response could be cached. or
     * <code>false</code> if the results of this request must not be cached.
     */
    public boolean isCacheable(HttpServletRequest request);

    /** isRefreshNeeded: is the response to given request be refreshed?
     * @param request incoming <code>HttpServletRequest</code> object
     * @returns <code>true</code> if the response needs to be refreshed.
     * or return <code>false</code> if the results of this request
     * don't need to be refreshed.
     */
    public boolean isRefreshNeeded(HttpServletRequest request);

    /** get timeout for the cached response.
     * @param request incoming <code>HttpServletRequest</code> object
     * @returns the timeout in seconds for the cached response; a return
     * value of -1 means the response never expires and a value of -2 indicates

```

```

    * helper cannot determine the timeout (container assigns default timeout)
    */
public int getTimeout(HttpServletRequest request);

/**
 * Stop the helper from active use
 * @exception Exception if an error occurs
 */
public void destroy() throws Exception;
}

```

## CacheKeyGenerator Interface

The built-in default `CacheHelper` implementation allows web applications to customize the key generation. An application component (in a servlet or JSP) can set up a custom `CacheKeyGenerator` implementation as an attribute in the `ServletContext`.

The name of the context attribute is configurable as the value of the `cacheKeyGeneratorAttrName` property in the `default-helper` element of the `sun-web.xml` deployment descriptor. For more information, see “default-helper,” on page 111.

Here is the `CacheKeyGenerator` interface:

```

package com.sun.appserv.web.cache;

import javax.servlet.ServletContext;
import javax.servlet.http.HttpServletRequest;

/** CacheKeyGenerator: a helper interface to generate the key that
 *  is used to cache this request.
 *
 *  * Name of the ServletContext attribute implementing the
 *  * CacheKeyGenerator is configurable via a property of the
 *  * default-helper in sun-web.xml:
 *  * <default-helper>
 *  *   <property
 *  *     name="cacheKeyGeneratorAttrName"
 *  *     value="com.acme.web.MyCacheKeyGenerator" />
 *  * </default-helper>
 *
 *  * Caching engine looks up the specified attribute in the servlet
 *  * context; the result of the lookup must be an implementation of the
 *  * CacheKeyGenerator interface.
 */

```

```

public interface CacheKeyGenerator {

    /**
     * getCacheKey: generate the key to be used to cache the
     * response.
     * @param context the web application context
     * @param request incoming HttpServletRequest
     * @returns key string used to access the cache entry.
     * if the return value is null, a default key is used.
     */
    public String getCacheKey(ServletContext context,
                              HttpServletRequest request);
}

```

## About the Servlet Engine

Servlets exist in and are managed by the servlet engine in the Sun ONE Application Server. The servlet engine is an internal object that handles all servlet meta functions. These functions include instantiation, initialization, destruction, access from other components, and configuration management.

## Instantiating and Removing Servlets

After the servlet engine instantiates the servlet, the servlet engine runs its `init()` method to perform any necessary initialization. Override this method to perform an initialize a function for the servlet's life, such as initializing a counter.

When a servlet is removed from service, the server engine calls the `destroy()` method in the servlet so that the servlet can perform any final tasks and deallocate resources. Override this method to write log messages or clean up any lingering connections that won't be caught in garbage collection.

## Request Handling

When a request is made, the Sun ONE Application Server hands the incoming data to the servlet engine. The servlet engine processes the request's input data, such as form data, cookies, session information, and URL name-value pairs, into an `HttpServletRequest` request object type.

The servlet engine also creates an `HttpServletResponse` response object type. The engine then passes both as parameters to the servlet's `service()` method.

In an HTTP servlet, the default `service()` method routes requests to another method based on an HTTP transfer method, such as `POST`, `GET`, and so on. For example, HTTP `POST` requests are sent to the `doPost()` method, HTTP `GET` requests are sent to the `doGet()` method, and so on. This enables the servlet to process request data differently, depending on which transfer method is used. Since the routing takes place in the service method, you generally do not override `service()` in an HTTP servlet. Instead, override `doGet()`, `doPost()`, and so on, depending on the request type you expect.

---

**TIP** To enable automatic routing in an HTTP servlet, call `request.getMethod()`, which provides the HTTP transfer method. Since request data is already preprocessed into a name value list in the Sun ONE Application Server, you could simply override the `service()` method in an HTTP servlet without losing functionality. However, this does make the servlet less portable, since it is now dependent on preprocessed request data.

---

To perform the tasks to answer a request, override the `service()` method for generic servlets, and the `doGet()` or `doPost()` methods for HTTP servlets. Very often, this means accessing EJB components to perform business transactions, collating the information in the request object or in a `JDBC ResultSet` object, and then passing the newly generated content to a JSP for formatting and delivery back to the user.

## Allocating Servlet Engine Resources

By default, the servlet engine creates a thread for each new request. This is less resource intensive than instantiating a new servlet copy in memory for each request. Avoid threading issues, since each thread operates in the same memory space where servlet object variables can overwrite each other.

If a servlet is specifically written as a single thread, the servlet engine creates a pool of servlet instances to be used for incoming requests. If a request arrives when all instances are busy, it is queued until an instance becomes available. The number of pool instances is configurable in the `sun-web.xml` file, in the `singleThreadedServletPoolSize` property of the `sun-web-app` element.

For more information about the `sun-web.xml` file, see Chapter 6, “Assembling and Deploying Web Modules.” For more information on threading issues, see “Handling Threading Issues,” on page 39.

# Using JavaServer Pages

This chapter describes how to use JavaServer Pages (JSPs) as page templates in a Sun ONE Application Server web application.

This chapter contains the following sections:

- Introducing JSPs
- Creating JSPs
- JSP Tag Libraries and Standard Portable Tags
- JSP Caching
- Compiling JSPs: The Command-Line Compiler
- Debugging JSPs

## Introducing JSPs

JSPs are browser pages in HTML or XML. They also contain Java code, which enables them to perform complex processing, conditionalize output, and communicate with other application objects. JSPs in Sun ONE Application Server are based on the JSP 1.2 specification. This specification is accessible from *install\_dir/docs/index.htm*; *install\_dir* is where the Sun ONE Application Server is installed.

In a Sun ONE Application Server application, JSPs are the individual pages that make up an application. You can call a JSP from a servlet to handle the user interaction output, or, since JSPs have the same application environment access as any other application component, you can use a JSP as an interaction destination.

JSPs are made up of JSP elements and *template data*. *Template data* is anything not in the JSP specification, including text and HTML tags. For example, the minimal JSP requires no processing by the JSP engine and is a static HTML page.

The Sun ONE Application Server compiles JSPs into HTTP servlets the first time they are called (or they can be precompiled for better performance). This makes them available to the application environment as standard objects and enables them to be called from a client using a URL.

JSPs run inside the server's JSP engine, which is responsible for interpreting JSP specific tags and performing the actions they specify in order to generate dynamic content. This content, along with any template data surrounding it, is assembled into an output page and is returned to the caller.

## Creating JSPs

You create JSPs in basically the same way you create HTML files. You can use an HTML editor to create pages and edit the page layout. You make a page a JSP by inserting JSP-specific tags into the raw source code where needed, and by giving the file a `.jsp` extension.

JSPs that adhere to the JSP 1.2 specification follow XML syntax for the most part, which is consistent with HTML. For a summary of the JSP tags you can use, see "JSP Tag Libraries and Standard Portable Tags," on page 55.

JSPs are compiled into servlets, so servlet design considerations also apply to JSPs. JSPs and servlets can perform the same tasks, but each excels at one task at the expense of the other. Servlets are strong in processing and adaptability. However, performing HTML output from them involves many cumbersome `println` statements that must be coded by hand. Conversely, JSPs excel at layout tasks because they are simply HTML files and can be created with HTML editors, though performing complex computational or processing tasks with them is awkward. For information about servlets, see Chapter 2, "Using Servlets."

Here are a few additional JSP design tips:

- Designing for Ease of Maintenance
- Designing for Portability
- Handling Exceptions

## Designing for Ease of Maintenance

Each JSP can call or include any other JSP. For example, you can create a generic corporate banner, a standard navigation bar, and a left-side column table of contents, where each element is in a separate JSP and is included for each page built. The page can be constructed with a JSP functioning as a frameset, dynamically determining the pages to load into each subframe. A JSP can also be included when the JSP is compiled into a servlet or when a request arrives.

## Designing for Portability

JSPs can be completely portable between different applications and different servers. A disadvantage is that they have no particular application data knowledge, but this is only a problem if they require that kind of data.

One possible use for generic JSPs is for portable page elements, such as navigation bars or corporate headers and footers, which are meant to be included in other JSPs. You can create a library of reusable generic page elements to use throughout an application, or even among several applications.

For example, the minimal generic JSP is a static HTML page with no JSP-specific tags. A slightly less minimal JSP might contain some Java code that operates on generic data, such as printing the date and time, or that makes a change to the page's structure based on a standard value set in the request object.

## Handling Exceptions

If an uncaught exception occurs in a JSP file, Sun ONE Application Server generates an exception, usually a 404 or 500 error. To avoid this problem, set the `errorPage` attribute of the `<%@ page %>` tag.

# JSP Tag Libraries and Standard Portable Tags

Sun ONE Application Server supports tag libraries and standard portable tags. For more information about tag libraries, see the JSP 1.2 specification at:

<http://java.sun.com/products/jsp/download.html>

For a handy summary of JSP 1.2 tag syntax, see the following PDF file:

<http://java.sun.com/products/jsp/pdf/card12.pdf>

# JSP Caching

JSP caching lets you cache JSP page fragments within the Java engine. Each can be cached using different cache criteria. For example, suppose you have page fragments to view stock quotes, weather information, and so on. The stock quote fragment can be cached for 10 minutes, the weather report fragment for 30 minutes, and so on.

For more information about response caching as it pertains to servlets, see “Caching Servlet Results,” on page 45.

JSP caching uses the custom tag library support provided by JSP 1.2. JSP caching is implemented by a tag library packaged into the *install\_dir/lib/appserv-tags.jar* file, which you can copy into the `WEB-INF/lib` directory of your web application. The `appserv-tags.tld` tag description file is in this JAR file and in the *install\_dir/lib/tlds* directory.

You refer to these tags in your JSP files as follows:

```
<%@ taglib prefix="prefix" uri="Sun ONE Application Server Tags" %>
```

Subsequently, the cache tags are available as `<prefix:cache>` and `<prefix:flush>`. For example, if your *prefix* is `mypfx`, the cache tags are available as `<mypfx:cache>` and `<mypfx:flush>`.

If you wish to use a different URI for this tag library, you can use an explicit `<taglib>` element in your `web.xml` file.

The tags are as follows:

- `cache`
- `flush`

## cache

The `cache` tag caches the body between the beginning and ending tags according to the attributes specified. The first time the tag is encountered, the body content is executed and cached. Each subsequent time it is run, the cached content is checked to see if it needs to be refreshed and if so, it is executed again, and the cached data is refreshed. Otherwise, the cached data is served.

### Attributes

The following table describes attributes for the `cache` tag. The left column lists the attribute name, the middle column indicates the default value, and the right column describes what the attribute does.



## cache attributes

Attribute	Default	Description
key	<i>ServletPath_Suffix</i>	(optional) The name used by the container to access the cached entry. The cache key is suffixed to the servlet path to generate a key to access the cached entry. If no key is specified, a number is generated according to the position of the tag in the page.
timeout	60s	(optional) The time in seconds after which the body of the tag is executed and the cache is refreshed. By default, this value is interpreted in seconds. To specify a different unit of time, add a suffix to the timeout value as follows: s for seconds, m for minutes, h for hours, d for days. For example, 2h specifies two hours.
nocache	false	(optional) If set to true, the body content is executed and served as if there were no cache tag. This offers a way to programmatically decide whether the cached response should be sent or whether the body has to be executed, though the response is not cached.
refresh	false	(optional) If set to true, the body content is executed and the response is cached again. This lets you programmatically refresh the cache immediately regardless of the timeout setting.

**Example**

The following example represents a cached JSP page:

```
<%@ taglib prefix="mypfx" uri="Sun ONE Application Server Tags" %>

<%
    String cacheKey = null;
    if (session != null)
        cacheKey = (String)session.getAttribute("loginId");

    // check for nocache
    boolean noCache = false;
    String nc = request.getParameter("nocache");
    if (nc != null)
        noCache = "true";

    // force reload
    boolean reload=false;
    String refresh = request.getParameter("refresh");
```

```

        if (refresh != null)
            reload = true;
    %>

<myafx:cache key="<%= cacheKey %>" nocache="<%= noCache %>"
refresh="<%= reload %>" timeout="10m">
<%
    String page = request.getParameter("page");
    if (page.equals("frontPage") {
        // get headlines from database
    } else {
        .....
    %>
</myafx:cache>

<myafx:cache timeout="1h">
<h2> Local News </h2>
<%
    // get the headline news and cache them
%>
</myafx:cache>

```

## flush

Forces the cache to be flushed. If a `key` is specified, only the entry with that key is flushed. If no key is specified, the entire cache is flushed.

### Attributes

The following table describes attributes for the `flush` tag. The left column lists the attribute name, the middle column indicates the default value, and the right column describes what the attribute does.

flush attributes

Attribute	Default	Description
key	<i>ServletPath_Suffix</i>	(optional) The name used by the container to access the cached entry. The cache key is suffixed to the servlet path to generate a key to access the cached entry. If no key is specified, a number is generated according to the position of the tag in the page.

**Examples**

To flush the entry with `key="foobar"`:

```
<myafx:flush key="foobar" />
```

To flush the entire cache:

```
<% if (session != null && session.getAttribute("clearCache") != null) { %>
    <myafx:flush />
<% } %>
```

## Compiling JSPs: The Command-Line Compiler

Sun ONE Application Server provides the following ways of compiling JSP 1.2 compliant source files into servlets:

- JSPs are automatically compiled at runtime.
- The `asadmin deploy` command has a `precompilejsp` option; see the *Sun ONE Application Server Developer's Guide*.
- The `sun-appserv-jspc` Ant task allows you to precompile JSPs; see the *Sun ONE Application Server Developer's Guide*.
- The `jspc` command line tool, described in this section, allows you to precompile JSPs at the command line.

To allow the JSP container to pick up the precompiled JSPs from a JAR file, you must disable dynamic reloading of JSPs. To do this, set the `reload-interval` property to `-1` in the `jsp-config` element of the `sun-web.xml` file. See “JSP Elements,” on page 119.

The `jspc` command line tool is located under `install_dir/bin` (make sure this directory is in your path). The format of the `jspc` command is as follows:

```
jspc [options] file_specifier
```

The following table shows what `file_specifier` can be in the `jspc` command. The left column lists file specifiers, and the right column lists descriptions of those file specifiers.

File specifiers for the `jspc` command

File Specifier	Description
<code>files</code>	One or more JSP files to be compiled.

File specifiers for the `jspc` command

File Specifier	Description
<code>-webapp dir</code>	A directory containing a web application. All JSPs in the directory and its subdirectories are compiled. You cannot specify a WAR, JAR, or ZIP file; you must first extract it to an open directory structure.

The following table shows the basic *options* for the `jspc` command. The left column lists options, and the right column lists descriptions of those options.

Basic `jspc` options

Option	Description
<code>-q</code>	Enables quiet mode (same as <code>-v0</code> ). Only fatal error messages are displayed.
<code>-d dir</code>	Specifies the output directory for the compiled JSPs. Package directories are automatically generated based on the directories containing the uncompiled JSPs. The default top-level directory is the directory from which <code>jspc</code> is invoked.
<code>-p name</code>	Specifies the name of the target package for all specified JSPs, overriding the default package generation performed by the <code>-d</code> option.
<code>-c name</code>	Specifies the target class name of the first JSP compiled. Subsequent JSPs are unaffected.
<code>-uribase dir</code>	Specifies the URI directory to which compilations are relative. Applies only to JSP files listed in the command, and not to JSP files specified with <code>-webapp</code> .  This is the location of each JSP file relative to the <code>uriroot</code> . If this cannot be determined, the default is <code>/</code> .
<code>-uriroot dir</code>	Specifies the root directory against which URI files are resolved. Applies only to JSP files listed in the command, and not to JSP files specified with <code>-webapp</code> .  If this option is not specified, all parent directories of the first JSP page are searched for a <code>WEB-INF</code> subdirectory. The closest directory to the JSP page that has one is used.  If none of the JSP's parent directories have a <code>WEB-INF</code> subdirectory, the directory from which <code>jspc</code> is invoked is used.

Basic `jspc` options

Option	Description
<code>-genclass</code>	Compiles the generated servlets into class files.

The following table shows the advanced *options* for the `jspc` command. The left column lists options, and the right column lists descriptions of those options.

Advanced `jspc` options

Option	Description
<code>-v[<i>level</i>]</code>	Enables verbose mode. The <i>level</i> is optional; the default is 2. Possible <i>level</i> values are: <ul style="list-style-type: none"> <li>• 0 - fatal error messages only</li> <li>• 1 - error messages only</li> <li>• 2 - error and warning messages only</li> <li>• 3 - error, warning, and informational messages</li> <li>• 4 - error, warning, informational, and debugging messages</li> </ul>
<code>-mapped</code>	Generates separate <code>write</code> calls for each HTML line and comments that describe the location of each line in the JSP file. By default, all adjacent <code>write</code> calls are combined and no location comments are generated.
<code>-die[<i>code</i>]</code>	Returns the error number specified by <i>code</i> if an error occurs. If the <i>code</i> is absent or unparsable it defaults to 1.
<code>-webinc <i>file</i></code>	Creates partial servlet mappings for the <code>-webapp</code> option, which can be pasted into a <code>web.xml</code> file.
<code>-webxml <i>file</i></code>	Creates an entire <code>web.xml</code> file for the <code>-webapp</code> option.
<code>-ieplugin <i>class_id</i></code>	Specifies the Java plugin COM class ID for Internet Explorer. Used by the <code>&lt;jsp:plugin&gt;</code> tags.

For example, this command compiles the `hello` JSP file and writes the compiled JSP under `hellodir`:

```
jspc -d hellodir -genclass hello.jsp
```

This command compiles all the JSP files in the web application under `webappdir` into class files under `jspclassdir`:

```
jspc -d jspclassdir -genclass -webapp webappdir
```

To use either of these precompiled JSPs in a web application, put the classes under `hellodir` or `jspclassdir` into a JAR file, place the JAR file under `WEB-INF/lib`, and set the `reload-interval` property to `-1` in the `sun-web.xml` file.

## Debugging JSPs

When you use Sun ONE Studio 4 to debug JSPs, you can set breakpoints in either the JSP code or the generated servlet code, and you can switch between them and see the same breakpoints in both.

To set up debugging in Sun ONE Studio, see the *Sun ONE Application Server Developer's Guide*. For further details, see the *Sun ONE Studio 4, Enterprise Edition Tutorial*.

# Creating and Managing User Sessions

This chapter describes how to create and manage a session that allows users and transaction information to persist between interactions.

This chapter contains the following sections:

- Introducing Sessions
- How to Use Sessions
- Session Managers

## Introducing Sessions

The term user session refers to a series of user application interactions that are tracked by the server. Sessions are used for maintaining user specific state, including persistent objects (like handles to EJB components or database result sets) and authenticated user identities, among many interactions. For example, a session could be used to track a validated user login followed by a series of directed activities for a particular user.

The session itself resides in the server. For each request, the client transmits the session ID in a cookie or, if the browser does not allow cookies, the server automatically writes the session ID into the URL.

The Sun ONE Application Server supports the servlet standard session interface, called `HttpSession`, for all session activities. This interface enables you to write portable, secure servlets.

## Sessions and Cookies

A cookie is a small collection of information that can be transmitted to a calling browser, which retrieves it on each subsequent call from the browser so that the server can recognize calls from the same client. A cookie is returned with each call to the site that created it, unless it expires.

Sessions are maintained automatically by a session cookie that is sent to the client when the session is first created. The session cookie contains the session ID, which identifies the client to the browser on each successive interaction. If a client does not support or allow cookies, the server rewrites the URLs where the session ID appears in the URLs from that client.

You can configure whether and how sessions use cookies. See the `session-properties` and `cookie-properties` elements in the `sun-web.xml` file, described in Chapter 6, “Assembling and Deploying Web Modules.”

## Sessions and URL Rewriting

There are two situations in which the Sun ONE Application Server plugin performs implicit URL rewriting:

- When a response comes back from the Sun ONE Application Server; if implicit URL rewriting has been chosen, the plugin rewrites the URLs in the response before passing the response on to the client.
- When the request given by a client need not be sent to the Sun ONE Application Server and can be served on the web server side. Such requests may occur in the middle of a session and the response may need to be rewritten.

You can configure whether sessions use URL rewriting. See the `session-properties` element in the `sun-web.xml` file, described in Chapter 6, “Assembling and Deploying Web Modules.”

## Sessions and Security

The Sun ONE Application Server security model is based on an authenticated user session. Once a session has been created the application user is authenticated (if authentication is used) and logged in to the session. Each interaction step from the servlet that receives an EJB request does two things: generates content for a JSP to format the output, and checks that the user is properly authenticated.



Additionally, you can specify that a session cookie is only passed on a secured connection (that is, HTTPS), so the session can only remain active on a secure channel.

For more information about security, see Chapter 5, “Securing Web Applications.”

## How to Use Sessions

To use a session, first create a session using the `HttpServletRequest` method `getSession()`. Once the session is established, examine and set its properties using the provided methods. If desired, set the session to time out after being inactive for a defined time period or invalidate it manually. You can also bind objects to the session which store them for use by other components.

### Creating or Accessing a Session

To create a new session or to gain access to an existing session, use the `HttpServletRequest` method `getSession()`, as shown in the following example:

```
HttpSession mySession = request.getSession();
```

`getSession()` returns the valid session object associated with the request, identified in the session cookie which is encapsulated in the request object. Calling the method with no arguments, creates a session if one does not already exist which is associated with the request. Additionally, calling the method with a Boolean argument creates a session only if the argument is `true`.

The following example shows the `doPost()` method from a servlet which only performs the servlet’s main functions, if the session is present. Note that, the `false` parameter to `getSession()` prevents the servlet from creating a new session if one does not already exist:

```
public void doPost (HttpServletRequest req,
                   HttpServletResponse res)
    throws ServletException, IOException
{
    if ( HttpSession session = req.getSession(false) )
    {
        // session retrieved, continue with servlet operations
    }
    else
```

```

        // no session, return an error page
    }
}

```

---

**NOTE** The `getSession()` method should be called before anything is written to the response stream. Otherwise the `SetCookie` string is placed in the HTTP response body instead of the HTTP header.

---

For more information about `getSession()`, see the Java Servlet Specification v2.3.

## Examining Session Properties

Once a session ID has been established, use the methods in the `HttpSession` interface to examine session properties, and methods in the `HttpServletRequest` interface to examine request properties that relate to the session.

The following table shows the methods to examine session properties. The left column lists `HttpSession` methods, and the right column lists descriptions of these methods.

### HttpSession Methods

HttpSession method	Description
<code>getCreationTime()</code>	Returns the session time in milliseconds since January 1, 1970, 00:00:00 GMT.
<code>getId()</code>	Returns the assigned session identifier. An HTTP session's identifier is a unique string which is created and maintained by the server.
<code>getLastAccessedTime()</code>	Returns the last time the client sent a request carrying the assigned session identifier (or -1 if its a new session) in milliseconds since January 1, 1970, 00:00:00 GMT.
<code>isNew()</code>	Returns a Boolean value indicating if the session is new. Its a new session, if the server has created it and the client has not sent a request to it. This means, the client has not <i>acknowledged</i> or <i>joined</i> the session and may not return the correct session identification information when making its next request.

For example:

```
String mySessionID = mySession.getId();
if ( mySession.isNew() ) {
    log.println(currentDate);
    log.println("client has not yet joined session " + mySessionID);
}
```

The following table shows the methods to examine servlet request properties. The left column lists `HttpServletRequest` methods, and the right column lists descriptions of these methods.

#### HttpServletRequest Methods

HttpServletRequest Methods	Description
<code>getRemoteUser()</code>	Gets the requesting user name (HTTP authentication can provide the information). Returns null if the request has no user name information.
<code>getRequestedSessionId()</code>	Returns the session ID specified with the request. This may differ from the session ID in the current session if the session ID given by the client is invalid and a new session was created. Returns null if the request does not have a session associated with it.
<code>isRequestedSessionIdValid()</code>	Checks if the request is associated to a currently valid session. If the session requested is not valid, it is not returned through the <code>getSession()</code> method.
<code>isRequestedSessionIdFromCookie()</code>	Returns true if the request's session ID provided by the client is a cookie, or false otherwise.
<code>isRequestedSessionIdFromURL()</code>	Returns true if the request's session ID provided by the client is a part of a URL, or false otherwise.

For example:

```
if ( request.isRequestedSessionIdValid() ) {
    if ( request.isRequestedSessionIdFromCookie() ) {
        // this session is maintained in a session cookie
    }
    // any other tasks that require a valid session
} else {
    // log an application error
}
```

## Binding Data to a Session

You can bind objects to sessions in order to make them available across multiple user interactions.

The following table shows the `HttpSession` methods that provide support for binding objects to the session object. The left column lists `HttpSession` methods, and the right column lists descriptions of these methods.

### HttpSession Methods

<code>HttpSession</code> Methods	Description
<code>getAttribute()</code>	Returns the object bound to a given name in the session or null if there is no such binding.
<code>getAttributeNames()</code>	Returns an array of names of all attributes bound to the session.
<code>setAttribute()</code>	Binds the specified object into the session with the given name. Any existing binding with the same name is overwritten. For an object bound into the session to be distributed it must implement the <code>serializable</code> interface.
<code>removeAttribute()</code>	Unbinds an object in the session with the given name. If there is no object bound to the given name this method does nothing.

### *Binding Notification with HttpSessionBindingListener*

Some objects require you to know when they are placed in or removed from, a session. To obtain this information, implement the `HttpSessionBindingListener` interface in those objects. When your application stores or removes data with the session, the servlet engine checks whether the object being bound or unbound implements `HttpSessionBindingListener`. If it does, the Sun ONE Application Server notifies the object under consideration, through the `HttpSessionBindingListener` interface, that it is being bound into or unbound from the session.

## Invalidating a Session

Specify the session to invalidate itself automatically after being inactive for a defined time period. Alternatively, invalidate the session manually with the `HttpSession` method `invalidate()`.

---

**TIP** The session API does not provide an explicit session logout API, so any *logout* implementation must call the `session.invalidate()` API.

---

### *Invalidating a Session Manually*

To invalidate a session manually, simply call the following method:

```
session.invalidate();
```

All objects bound to the session are removed.

### *Setting a Session Timeout*

Session timeout is set using the `sun-web.xml` deployment descriptor file. For more information, see the `session-properties` element in Chapter 6, “Assembling and Deploying Web Modules.”

## Session Managers

A session manager automatically creates new session objects whenever a new session starts. In some circumstances, clients do not join the session, for example, if the session manager uses cookies and the client does not accept cookies.

Sun ONE Application Server 7 gives you these session management options:

- `StandardManager`, the default session manager
- `PersistentManager`, a provided session manager that uses a persistent data store

---

**NOTE** The session manager interface is Unstable. An unstable interface may be experimental or transitional, and hence may change incompatibly, be removed, or be replaced by a more stable interface in the next release.

---

## StandardManager

The `StandardManager` is the default session manager.

### Enabling StandardManager

You may want to specify `StandardManager` explicitly to change its default parameters. To do so, edit the `sun-web.xml` file for the web application as in the following example.

```
<sun-web-app>
  ...
  <session-config>
    <session-manager>
      <manager-properties>
        <property name="reapIntervalSeconds" value="20" />
      </manager-properties>
    </session-manager>
  ...
</session-config>
...
</sun-web-app>
```

For more information about the `sun-web.xml` file, see Chapter 6, “Assembling and Deploying Web Modules.”

### Manager Properties for StandardManager

The following table describes `manager-properties` properties for the `StandardManager` session manager. The left column lists the property name, the middle column indicates the default value, and the right column describes what the property does.

#### `manager-properties` properties

Property Name	Default Value	Description
<code>reapIntervalSeconds</code>	60	Specifies the number of seconds between checks for expired sessions.  Setting this value lower than the frequency at which session data changes is recommended. For example, this value should be as low as possible (1 second) for a hit counter servlet on a frequently accessed website, or you could lose the last few hits each time you restart the server.

`manager-properties` properties

Property Name	Default Value	Description
<code>maxSessions</code>	-1	Specifies the maximum number of active sessions, or -1 (the default) for no limit.
<code>sessionFilename</code>	none; state is not preserved across restarts	Specifies the absolute or relative pathname of the file in which the session state is preserved between application restarts, if preserving the state is possible. A relative pathname is relative to the temporary directory for this web application.

## PersistentManager

The `PersistentManager` is the other session manager provided with Sun ONE Application Server. For session persistence, `PersistentManager` can use a file, to which each session is serialized. You can also create your own persistence mechanism.

### Enabling PersistentManager

You may want to specify `PersistentManager` explicitly to change its default parameters. To do so, edit the `sun-web.xml` file for the web application as in the following example. Note that `persistence-type` must be set to `file`.

```
<sun-web-app>
  ...
  <session-config>
    <session-manager persistence-type=file>
      <manager-properties>
        <property name=reapIntervalSeconds value=20 />
      </manager-properties>
      <store-properties>
        <property name=directory value=sessions />
      </store-properties>
    </session-manager>
  ...
</session-config>
  ...
</sun-web-app>
```

For more information about the `sun-web.xml` file, see Chapter 6, “Assembling and Deploying Web Modules.”

## Manager Properties for PersistentManager

The following table describes `manager-properties` properties for the `PersistentManager` session manager. The left column lists the property name, the middle column indicates the default value, and the right column describes what the property does.

### `manager-properties` properties

Property Name	Default Value	Description
<code>reapIntervalSeconds</code>	60	Specifies the number of seconds between checks for expired sessions.  Setting this value lower than the frequency at which session data changes is recommended. For example, this value should be as low as possible (1 second) for a hit counter servlet on a frequently accessed website, or you could lose the last few hits each time you restart the server.
<code>maxSessions</code>	-1	Specifies the maximum number of active sessions, or -1 (the default) for no limit.

## Store Properties for PersistentManager

The following table describes `store-properties` properties for the `PersistentManager` session manager. The left column lists the property name, the middle column indicates the default value, and the right column describes what the property does.

### `store-properties` properties

Property Name	Default Value	Description
<code>reapIntervalSeconds</code>	60	Specifies the number of seconds between checks for expired sessions for those sessions that are currently swapped out.  Setting this value lower than the frequency at which session data changes is recommended. For example, this value should be as low as possible (1 second) for a hit counter servlet on a frequently accessed website, or you could lose the last few hits each time you restart the server.



`store-properties` properties

Property Name	Default Value	Description
<code>directory</code>	directory specified by <code>javax.servlet.context.tempdir</code> context attribute	Specifies the absolute or relative pathname of the directory into which individual session files are written. A relative path is relative to the temporary work directory for this web application.



# Securing Web Applications

This chapter describes how to write a secure web application for the Sun ONE Application Server with components that perform user authentication and access authorization.

This chapter contains the following sections:

- User Authentication by Servlets
- User Authentication for Single Sign-on
- User Authorization by Servlets
- Fetching the Client Certificate
- Security for SHTML and CGI

## User Authentication by Servlets

The web-based login mechanisms required by the J2EE Specification, v1.3 are supported by the Sun ONE Application Server. These mechanisms include:

- HTTP Basic Authentication
- SSL Mutual Authentication
- Form-Based Login

The `login-config` element in the `web.xml` deployment descriptor file describes the authentication method used, the application's realm name displayed by the HTTP basic authentication, and the form login mechanism's attributes.

The `login-config` element syntax is as follows:

```
<!ELEMENT login-config  
(auth-method?, realm-name?, form-login-config?)>
```

---

**NOTE** The `auth-method` subelement of `login-config` is officially optional, but if it is not included, the server defaults to HTTP Basic Authentication, which is not very secure.

---

For more information regarding `web.xml` elements, see Chapter 13, “Deployment Descriptor,” of the Java Servlet Specification, v2.3.

For more information regarding `sun-web.xml` elements, see Chapter 6, “Assembling and Deploying Web Modules.”

For information about programmatic login, see the *Sun ONE Application Server Developer's Guide*.

## HTTP Basic Authentication

HTTP basic authentication (RFC2068) is supported by the Sun ONE Application Server. Because passwords are sent with base64 encoding, this authentication type is not very secure. Use of SSL or another equivalent transport encryption is recommended to protect the password during transmission.

## SSL Mutual Authentication

Secure Socket Layer (SSL) 3.0 and the means to perform mutual (client/server) certificate-based authentication is a J2EE Specification, v1.3 requirement. This security mechanism provides user authentication using HTTPS (HTTP over SSL).

The Sun ONE Application Server SSL mutual authentication mechanism (also known as HTTPS authentication) supports the following cipher suites:

```
SSL_RSA_EXPORT_WITH_RC4_40_MD5
SSL_RSA_EXPORT_WITH_RC2_CBC_40_MD5
SSL_RSA_EXPORT_WITH_DES40_CBC_SHA
SSL_DH_DSS_EXPORT_WITH_DES40_CBC_SHA
SSL_DH_RSA_EXPORT_WITH_DES40_CBC_SHA
SSL_DHE_DSS_EXPORT_WITH_DES40_CBC_SHA
SSL_DHE_RSA_EXPORT_WITH_DES40_CBC_SHA
```

## Form-Based Login

The login screen's look and feel cannot be controlled with the HTTP browser's built-in mechanisms. J2EE introduces the ability to package a standard HTML or Servlet/JSP based form for logging in. The login form is associated with a web protection domain (an HTTP realm) and is used to authenticate previously unauthenticated users.

Because passwords are sent in the clear (unless protected by the underlying transport), this authentication type is not very secure. Use of SSL or another equivalent transport encryption is recommended to protect the password during transmission.

In order for the authentication to proceed appropriately, the login form action must always be `j_security_check`.

The following is an HTML sample showing how to program the form in an HTML page:

```
<form method="POST" action="j_security_check">
  <input type="text" name="j_username">
  <input type="password" name="j_password">
</form>
```

You can specify the parameter encoding for the form. For details, see “parameter-encoding,” on page 123.

## User Authentication for Single Sign-on

The single sign-on across applications on the Sun ONE Application Server is supported by the Sun ONE Application Server servlets and JSPs. This feature allows multiple applications that require the same user sign-on information to share this information between them, rather than having the user sign-on separately for each application. These applications are created to authenticate the user one time, and when needed this authentication information is propagated to all other involved applications.

An example application using the single sign-on scenario could be a consolidated airline booking service that searches all airlines and provides links to different airline web sites. Once the user signs on to the consolidated booking service, the user information can be used by each individual airline site without requiring another sign-on.

Single sign-on operates according to the following rules:

- Single sign-on applies to web applications configured for the same realm and virtual server. The realm is defined by the `realm-name` element in the `web.xml` file. For information about virtual servers, see the *Sun ONE Application Server Administrator's Guide* or the *Sun ONE Application Server Administrator's Configuration File Reference*.
- As long as users access only unprotected resources in any of the web applications on a virtual server, they are not challenged to authenticate themselves.
- As soon as a user accesses a protected resource in any web application associated with a virtual server, the user is challenged to authenticate himself or herself, using the login method defined for the web application currently being accessed.
- Once authenticated, the roles associated with this user are used for access control decisions across all associated web applications, without challenging the user to authenticate to each application individually.
- When the user logs out of one web application (for example, by invalidating or timing out the corresponding session if form based login is used), the user's sessions in all web applications are invalidated. Any subsequent attempt to access a protected resource in any application requires the user to authenticate himself or herself again.

The single sign-on feature utilizes HTTP cookies to transmit a token that associates each request with the saved user identity, so it can only be used in client environments that support cookies.

To configure single sign-on, set the following properties in the `virtual-server` element of the `server.xml` file:

- `sso-enabled` - If `false`, single sign-on is disabled for this virtual server, and users must authenticate separately to every application on the virtual server. The default is `true`.
- `sso-max-inactive-seconds` - Specifies the time after which a user's single sign-on record becomes eligible for purging if no client activity is received. Since single sign-on applies across several applications on the same virtual server, access to any of the applications keeps the single sign-on record active. The default value is 5 minutes (300 seconds). Higher values provide longer single sign-on persistence for the users at the expense of more memory use on the server.

- `sso-reap-interval-seconds` - Specifies the interval between purges of expired single sign-on records. The default value is 60.

Here is an example configuration with all default values:

```
<virtual-server id="server1" ... >
    ...
    <property name="sso-enabled" value="true"/>
    <property name="sso-max-inactive-seconds" value="300"/>
    <property name="sso-reap-interval-seconds" value="60"/>
</virtual-server>
```

## User Authorization by Servlets

Servlets can be configured to only permit access to users with the appropriate authorization level. This section covers the following topics:

- Defining Roles
- Defining Servlet Authorization Constraints

### Defining Roles

You define roles in the J2EE deployment descriptor file, `web.xml`, and the corresponding role mappings in the Sun ONE Application Server deployment descriptor file, `sun-application.xml` (or `sun-web.xml` for individually deployed web modules). For more information about `sun-web.xml`, see Chapter 6, “Assembling and Deploying Web Modules.”

Each `security-role-mapping` element in the `sun-application.xml` or `sun-web.xml` file maps a role name permitted by the web application to principals and groups. For example, a `sun-web.xml` file for an individually deployed web module might contain the following:

```
<sun-web-app>
  <security-role-mapping>
    <role-name>manager</role-name>
    <principal-name>jgarcia</principal-name>
    <principal-name>mwebster</principal-name>
    <group-name>team-leads</group-name>
  </security-role-mapping>
  <security-role-mapping>
```

```

        <role-name>administrator</role-name>
        <principal-name>dsmith</principal-name>
    </security-role-mapping>
</sun-web-app>

```

Note that the `role-name` in this example must match the `role-name` in the `security-role` element of the corresponding `web.xml` file.

Note that for J2EE applications (EAR files), all security role mappings for the application modules must be specified in the `sun-application.xml` file. For individually deployed web modules, the roles are always specified in the `sun-web.xml` file. A role can be mapped to either specific principals or to groups (or both). The principal or group names used must be valid principals or groups in the current default realm.

## Defining Servlet Authorization Constraints

On the servlet level, you define access permissions using the `auth-constraint` element of the `web.xml` file.

The `auth-constraint` element on the resource collection must be used to indicate the user roles permitted to the resource collection. Refer to the Servlet specification for details on configuring servlet authorization constraints.

## Fetching the Client Certificate

When you enable SSL and require client certificate authorization, your servlets have access to the client certificate as shown in the following example:

```

if (request.isSecure()) {
    java.security.cert.X509Certificate[] certs;
    certs = request.getAttribute("javax.servlet.request.X509Certificate");
    if (certs != null) {
        clientCert = certs[0];
        if (clientCert != null) {
            // Get the Distinguished Name for the user.
            java.security.Principal userDN = clientCert.getSubjectDN();
            ...
        }
    }
}

```

The `userDn` is the fully qualified Distinguished Name for the user.



# Security for SHTML and CGI

For security, server-parsed HTML tags and CGI scripts depend on the server's security configuration. The following J2EE-only security features are not available for server-parsed HTML tags and CGI scripts:

- J2EE realms
- J2EE roles
- Form-based login
- Single sign-on
- Programmatic login
- J2EE authorization constraints

For more information about the server's security configuration, see the *Sun ONE Application Server Administrator's Guide to Security*.



# Assembling and Deploying Web Modules

This chapter describes how web modules are assembled and deployed in Sun ONE Application Server. For general assembly and deployment information, see the *Sun ONE Application Server Developer's Guide*.

The following topics are presented in this chapter:

- Web Application Structure
- Creating Web Deployment Descriptors
- Deploying Web Applications
- Dynamic Reloading of Web Applications
- The sun-web-app\_2\_3-0.dtd File
- Elements in the sun-web.xml File
- Sample Web Module XML Files

# Web Application Structure

Web Applications have a directory structure, all accessible from a mapping to the application's document root (for example, `/hello`). The document root contains JSP files, HTML files, and static files such as image files.

A WAR (web application archive) file contains a complete web application in compressed form.

A special directory under the document root, `WEB-INF`, contains everything related to the application that is not in the public document tree of the application. No file contained in `WEB-INF` can be served directly to the client. The contents of `WEB-INF` include:

- `/WEB-INF/classes/*`, the directory for servlet and other classes.
- `/WEB-INF/lib/*.jar`, the directory for JAR files containing beans and other utility classes.
- `/WEB-INF/web.xml` and `/WEB-INF/sun-web.xml`, XML-based deployment descriptors that specify the web application configuration, including mappings, initialization parameters, and security constraints.

The web application directory structure follows the structure outlined in the J2EE specification. Here is an example directory structure of a simple web application.

```
+ hello/
|--- index.jsp
|--+ META-INF/
|   |--- MANIFEST.MF
'--+ WEB-INF/
    |--- web.xml
    '--- sun-web.xml
```

Here is an example directory structure of a simple J2EE application containing a web module.

```

+ converter_1/
|--- converterClient.jar
|---+ META-INF/
|   |--- MANIFEST.MF
|   |--- application.xml
|   '--- sun-application.xml
|---+ war-ic_war/
|   |--- index.jsp
|   |---+ META-INF/
|   |   |--- MANIFEST.MF
|   |   '---+ WEB-INF/
|   |       |--- web.xml
|   |       '--- sun-web.xml
|---+ ejb-jar-ic_jar/
|   |--- Converter.class
|   |--- ConverterBean.class
|   |--- ConverterHome.class
|   '---+ META-INF/
|   |   |--- MANIFEST.MF
|   |   |--- ejb-jar.xml
|   |   '--- sun-ejb-jar.xml
|---+ app-client-ic_jar/
|   |--- ConverterClient.class
|   '---+ META-INF/
|   |   |--- MANIFEST.MF
|   |   |--- application-client.xml
|   |   '--- sun-application-client.xml

```

## Creating Web Deployment Descriptors

Sun ONE Application Server web modules include two deployment descriptor files:

- A J2EE standard file (`web.xml`), described in the Java Servlet Specification, v2.3, Chapter 13, “Deployment Descriptors.” You can find the specification here:

<http://java.sun.com/products/servlet/index.html>

- An optional Sun ONE Application Server specific file (`sun-web.xml`), described in this chapter.

The easiest way to create the `web.xml` and `sun-web.xml` files is to deploy a web module using the Administration interface or Sun ONE Studio 4. For more information, see the next section or the *Sun ONE Application Server Developer's Guide*. For example `web.xml` and `sun-web.xml` files, see "Sample Web Module XML Files," on page 124.

After you have created these files, you can edit them using the Administration interface or a combination of an editor and command line utilities such as Ant to reassemble and redeploy the updated deployment descriptor information. Apache Ant 1.4.1 is provided with Sun ONE Application Server. For more information, see the *Sun ONE Application Server Developer's Guide*.

## Deploying Web Applications

When you deploy, undeploy, or redeploy a web application, you do not need to restart the server. In other words, deployment is *dynamic*.

You can deploy a web application in these ways, which are described briefly:

- Using the Command Line
- Using the Administration Interface
- Using Sun ONE Studio

For more detailed information about deployment, see the *Sun ONE Application Server Developer's Guide*.

You can keep the generated source for JSPs by adding the `-keepgenerated` property to the `jsp-config` element in `sun-web.xml`. If you include this property when you deploy the web application, the generated source is kept in `instance_dir/generated/jsp/j2ee-apps/app_name/module_name` if it is in an application or `instance_dir/generated/jsp/j2ee-modules/module_name` if it is in an individually deployed web module.

## Using the Command Line

To deploy a web application using the command line:

1. Edit the deployment descriptor files (`web.xml` and `sun-web.xml`) by hand.
2. Execute an Ant build command (such as `build war`) to reassemble the WAR module.

3. Write the web application to a WAR file if desired. This is optional. For example:

```
jar -cvf module_name.war *
```

4. Use the `asadmin deploy` command to deploy the WAR module. The syntax is as follows:

```
asadmin deploy --user admin_user [--password admin_password]
[--passwordfile password_file] --host hostname --port adminport
[--secure | -s] [--virtualservers virtual_servers] [--type
application|ejb|web|connector] [--contextroot contextroot]
[--force=true] [--precompilejsp=false] [--verify=false] [--name
component_name] [--upload=true] [--retrieve local_dirpath] [--instance
instance_name] filepath
```

For example, the following command deploys a web application as an individual module:

```
asadmin deploy --user jadams --password secret --host localhost
--port 4848 --type web --instance server1 myWebApp.war
```

If `upload` is set to `false`, the `filepath` must be an absolute path on the server machine.

## Using the Administration Interface

To deploy a web application using the Administration interface:

1. Open the Applications component under your server instance.
2. Go to the Web Applications page.
3. Click on the Deploy button.
4. Enter the full path to the WAR module (or click on Browse to find it), then click on the OK button.
5. Enter the web application name and the context root.

You can also redeploy the web application if it already exists by checking the appropriate box. This is optional.

6. Assign the web application to one or more virtual servers by checking the boxes next to the virtual server names.
7. Click on the OK button.

## Using Sun ONE Studio

You can use Sun ONE Studio 4, to assemble and deploy web applications. For more information about using Sun ONE Studio, see the *Sun ONE Studio 4, Enterprise Edition Tutorial*.

---

**NOTE** In Sun ONE Studio, deploying web application is referred to as *executing* it.

---

## Dynamic Reloading of Web Applications

If you make code changes to a web application and *dynamic reloading* is enabled, you do not need to redeploy the web application or restart the server. To enable dynamic reloading, you can do one of the following:

- Use the Administration interface:
  - a. Open the Applications component under your server instance.
  - b. Go to the Applications page.
  - c. Check the Reload Enabled box to enable dynamic reloading.
  - d. Enter a number of seconds in the Reload Poll Interval field to set the interval at which applications and modules are checked for code changes and dynamically reloaded.
  - e. Click on the Save button.
  - f. Go to the server instance page and select the Apply Changes button.

For details, see the *Sun ONE Application Server Administrator's Guide*.

- Edit the following attributes of the `server.xml` file's `applications` element, then restart the server:
  - `dynamic-reload-enabled="true"` enables dynamic reloading.
  - `dynamic-reload-poll-interval-in-seconds` sets the interval at which applications and modules are checked for code changes and dynamically reloaded.

For details about `server.xml`, see the *Sun ONE Application Server Administrator's Configuration File Reference*.



In addition, to load new servlet files, reload EJB related changes, or reload deployment descriptor changes, you must do the following:

1. Create an empty file named `.reload` at the root of the deployed application:

```
instance_dir/applications/j2ee-apps/app_name/.reload
```

or individually deployed module:

```
instance_dir/applications/j2ee-modules/module_name/.reload
```

2. Explicitly update the `.reload` file's timestamp (`touch .reload` in UNIX) each time you make the above changes.

For JSPs, changes are reloaded automatically at a frequency set in the `reload-interval` property of the `jsp-config` element in the `sun-web.xml` file. To disable dynamic reloading of JSPs, set the `reload-interval` property to `-1`.

## The sun-web-app\_2\_3-0.dtd File

The `sun-web-app_2_3-0.dtd` file defines the structure of the `sun-web.xml` file, including the elements it can contain and the subelements and attributes these elements can have. The `sun-web-app_2_3-0.dtd` file is located in the `install_dir/lib/dtds` directory.

---

**NOTE** Do not edit the `sun-web-app_2_3-0.dtd` file; its contents change only with new versions of Sun ONE Application Server.

---

For general information about DTD files and XML, see the XML specification at:

<http://www.w3.org/TR/REC-xml>

Each element defined in a DTD file (which may be present in the corresponding XML file) can contain the following:

- Subelements
- Data
- Attributes

## Subelements

Elements can contain subelements. For example, the following file fragment defines the `cache` element.

```
<!ELEMENT cache (cache-helper*, default-helper?, property*, cache-mapping*)>
```

The `ELEMENT` tag specifies that a `cache` element can contain `cache-helper`, `default-helper`, `property`, and `cache-mapping` subelements.

The following table shows how optional suffix characters of subelements determine the requirement rules, or number of allowed occurrences, for the subelements. The left column lists the subelement ending character, and the right column lists the corresponding requirement rule.

requirement rules and subelement suffixes

Subelement Suffix	Requirement Rule
<i>element*</i>	Can contain <i>zero or more</i> of this subelement.
<i>element?</i>	Can contain <i>zero or one</i> of this subelement.
<i>element+</i>	Must contain <i>one or more</i> of this subelement.
<i>element</i> (no suffix)	Must contain <i>only one</i> of this subelement.

If an element cannot contain other elements, you see `EMPTY` or `(#PCDATA)` instead of a list of element names in parentheses.

## Data

Some elements contain character data instead of subelements. These elements have definitions of the following format:

```
<!ELEMENT element-name (#PCDATA)>
```

For example:

```
<!ELEMENT description (#PCDATA)>
```

In the `sun-web.xml` file, white space is treated as part of the data in a data element. Therefore, there should be no extra white space before or after the data delimited by a data element. For example:

```
<description>class name of session manager</description>
```

## Attributes

Elements that have `ATTLIST` tags contain attributes (name-value pairs). For example:

```
<!ATTLIST cache    max-capacity  CDATA    "4096"
                  timeout        CDATA    "30"
                  enabled        %boolean; "false">
```

A `cache` element can contain `max-capacity`, `timeout`, and `enabled` attributes.

The `#REQUIRED` label means that a value must be supplied. The `#IMPLIED` label means that the attribute is optional, and that Sun ONE Application Server generates a default value. Wherever possible, explicit defaults for optional attributes (such as `"true"`) are listed.

Attribute declarations specify the type of the attribute. For example, `CDATA` means character data, and `%boolean` is a predefined enumeration.

## Elements in the sun-web.xml File

This section describes the XML elements in the `sun-web.xml` file. Elements are grouped as follows:

- General Elements
- Security Elements
- Session Elements
- Reference Elements
- Caching Elements
- Classloader Elements
- JSP Elements
- Internationalization Elements

---

**NOTE** Subelements must be defined in the order in which they are listed under each **Subelements** heading unless otherwise noted.

---

## General Elements

General elements are as follows:

- `sun-web-app`
- `property`
- `description`

### **sun-web-app**

Defines Sun ONE Application Server specific configuration for a web module. This is the root element; there can only be one `sun-web-app` element in a `sun-web.xml` file.

#### **Subelements**

The following table describes subelements for the `sun-web-app` element. The left column lists the subelement name, the middle column indicates the requirement rule, and the right column describes what the element does.

sun-web-app subelements

Element	Required	Description
<code>security-role-mapping</code>	zero or more	Maps roles to users or groups in the currently active realm.
<code>servlet</code>	zero or more	Specifies a principal name for a servlet, which is used for the <code>run-as</code> role defined in <code>web.xml</code> .
<code>session-config</code>	zero or one	Specifies session manager, session cookie, and other session-related information.
<code>resource-env-ref</code>	zero or more	Maps the absolute JNDI name to the <code>resource-env-ref</code> in the corresponding J2EE XML file.
<code>resource-ref</code>	zero or more	Maps the absolute JNDI name to the <code>resource-ref</code> in the corresponding J2EE XML file.
<code>ejb-ref</code>	zero or more	Maps the absolute JNDI name to the <code>ejb-ref</code> in the corresponding J2EE XML file.
<code>cache</code>	zero or one	Configures caching for web application components.

## sun-web-app subelements (Continued)

Element	Required	Description
class-loader	zero or one	Specifies classloader configuration information.
jsp-config	zero or one	Specifies JSP configuration information.
locale-charset-info	zero or one	Specifies internationalization settings.
property	zero or more	Specifies a property, which has a name and a value.

**Attributes**

none

**Properties**

The following table describes properties for the sun-web-app element. The left column lists the property name, the middle column indicates the default value, and the right column describes what the property does.

## sun-web-app properties

Property Name	Default Value	Description
crossContextAllowed	true	If true, allows this web application to access the contexts of other web applications using the <code>ServletContext.getContext()</code> method.
tempdir	<i>instance_dir</i> /generated/ j2ee-apps/ <i>app_name</i> or <i>instance_dir</i> /generated/ j2ee-modules/ <i>module_</i> <i>name</i>	Specifies a temporary directory for use by this web module. This value is used to construct the value of the <code>javax.servlet.context.tempdir</code> context attribute. Compiled JSPs are also placed in this directory.
singleThreadedServletPoolSize	5	Specifies the maximum number of servlet instances allocated for each <code>SingleThreadModel</code> servlet in the web application.

## property

Specifies a property, which has a name and a value. A property adds configuration information to its parent element that is one or both of the following:

- Optional with respect to Sun ONE Application Server
- Needed by a system or object that Sun ONE Application Server doesn't have knowledge of, such as an LDAP server or a Java class

For example, a `manager-properties` element can include `property` subelements:

```
<manager-properties>
  <property name="reapIntervalSeconds" value="20" />
</manager-properties>
```

Which properties a `manager-properties` element uses depends on the value of the parent `session-manager` element's `persistence-type` attribute. For details, see the description of the `session-manager` element.

### Subelements

The following table describes subelements for the `property` element. The left column lists the subelement name, the middle column indicates the requirement rule, and the right column describes what the element does.

`property` subelements

Element	Required	Description
<code>description</code>	zero or one	Specifies an optional text description of a property.

### Attributes

The following table describes attributes for the `property` element. The left column lists the attribute name, the middle column indicates the default value, and the right column describes what the attribute does.

`property` attributes

Attribute	Default	Description
<code>name</code>	none	Specifies the name of the property.
<code>value</code>	none	Specifies the value of the property.

## description

Contains data that specifies a text description of the containing element.

### Subelements

none

### Attributes

none

## Security Elements

Security elements are as follows:

- `security-role-mapping`
- `servlet`
- `servlet-name`
- `role-name`
- `principal-name`
- `group-name`

## security-role-mapping

Maps roles to users or groups in the currently active realm. See the *Sun ONE Application Server Developer's Guide* for how to define the currently active realm.

### Subelements

The following table describes subelements for the `security-role-mapping` element. The left column lists the subelement name, the middle column indicates the requirement rule, and the right column describes what the element does.

`security-role-mapping` subelements

Element	Required	Description
<code>role-name</code>	only one	Contains the role name.
<code>principal-name</code>	requires at least one <code>principal-name</code> or <code>group-name</code>	Contains a principal (user) name in the current realm.
<code>group-name</code>	requires at least one <code>principal-name</code> or <code>group-name</code>	Contains a group name in the current realm.

**Attributes**

none

**servlet**

Specifies a principal name for a servlet, which is used for the `run-as` role defined in `web.xml`.

**Subelements**

The following table describes subelements for the `servlet` element. The left column lists the subelement name, the middle column indicates the requirement rule, and the right column describes what the element does.

`servlet` subelements

Element	Required	Description
<code>servlet-name</code>	only one	Contains the name of a servlet, which is matched to a <code>servlet-name</code> in <code>web.xml</code> .
<code>principal-name</code>	only one	Contains a principal (user) name in the current realm.

**Attributes**

none

**servlet-name**

Contains data that specifies the name of a servlet, which is matched to a `servlet-name` in `web.xml`. This name must be present in `web.xml`.

**Subelements**

none

**Attributes**

none

**role-name**

Contains data that specifies the `role-name` in the `security-role` element of the `web.xml` file.

**Subelements**

none



**Attributes**

none

**principal-name**

Contains data that specifies a principal (user) name in the current realm.

**Subelements**

none

**Attributes**

none

**group-name**

Contains data that specifies a group name in the current realm.

**Subelements**

none

**Attributes**

none

## Session Elements

Session elements are as follows:

- `session-config`
- `session-manager`
- `manager-properties`
- `store-properties`
- `session-properties`
- `cookie-properties`

---

**NOTE** The session manager interface is Unstable. An unstable interface may be experimental or transitional, and hence may change incompatibly, be removed, or be replaced by a more stable interface in the next release.

---

## session-config

Specifies session configuration information.

### Subelements

The following table describes subelements for the `session-config` element. The left column lists the subelement name, the middle column indicates the requirement rule, and the right column describes what the element does.

`session-config` subelements

Element	Required	Description
<code>session-manager</code>	zero or one	Specifies session manager configuration information.
<code>session-properties</code>	zero or one	Specifies session properties.
<code>cookie-properties</code>	zero or one	Specifies session cookie properties.

### Attributes

none

## session-manager

Specifies session manager information.

### Subelements

The following table describes subelements for the `session-manager` element. The left column lists the subelement name, the middle column indicates the requirement rule, and the right column describes what the element does.

`session-manager` subelements

Element	Required	Description
<code>manager-properties</code>	zero or one	Specifies session manager properties.
<code>store-properties</code>	zero or one	Specifies session persistence (storage) properties.

**Attributes**

The following table describes attributes for the `session-manager` element. The left column lists the attribute name, the middle column indicates the default value, and the right column describes what the attribute does.

`session-manager` attributes

Attribute	Default Value	Description
<code>persistence-type</code>	<code>memory</code>	(optional) Specifies the session persistence mechanism. Allowed values are <code>memory</code> and <code>file</code> .  The <code>custom</code> value is not implemented and should not be used.

**manager-properties**

Specifies session manager properties.

**Subelements**

The following table describes subelements for the `manager-properties` element. The left column lists the subelement name, the middle column indicates the requirement rule, and the right column describes what the element does.

`manager-properties` subelements

Element	Required	Description
<code>property</code>	zero or more	Specifies a property, which has a name and a value.

**Attributes**

none

**Properties**

The following table describes properties for the `manager-properties` element. The left column lists the property name, the middle column indicates the default value, and the right column describes what the property does.

`manager-properties` **properties**

Property Name	Default Value	Description
<code>reapIntervalSeconds</code>	60	Specifies the number of seconds between checks for expired sessions.  Setting this value lower than the frequency at which session data changes is recommended. For example, this value should be as low as possible (1 second) for a hit counter servlet on a frequently accessed website, or you could lose the last few hits each time you restart the server.
<code>maxSessions</code>	-1	Specifies the maximum number of active sessions, or -1 (the default) for no limit.
<code>sessionFilename</code>	none; state is not preserved across restarts	Specifies the absolute or relative pathname of the file in which the session state is preserved between application restarts, if preserving the state is possible. A relative pathname is relative to the temporary directory for this web module.  Applicable only if the <code>persistence-type</code> attribute of the <code>session-manager</code> element is <code>memory</code> .

**store-properties**

Specifies session persistence (storage) properties.

**Subelements**

The following table describes subelements for the `store-properties` element. The left column lists the subelement name, the middle column indicates the requirement rule, and the right column describes what the element does.

`store-properties` subelements

Element	Required	Description
<code>property</code>	zero or more	Specifies a property, which has a name and a value.

**Attributes**

none

## Properties

The following table describes properties for the `store-properties` element. The left column lists the property name, the middle column indicates the default value, and the right column describes what the property does.

### `store-properties` properties

Property Name	Default Value	Description
<code>reapIntervalSeconds</code>	60	Specifies the number of seconds between checks for expired sessions for those sessions that are currently swapped out.  Setting this value lower than the frequency at which session data changes is recommended. For example, this value should be as low as possible (1 second) for a hit counter servlet on a frequently accessed website, or you could lose the last few hits each time you restart the server.
<code>directory</code>	directory specified by <code>javax.servlet.context.tempdir</code> context attribute	Specifies the absolute or relative pathname of the directory into which individual session files are written. A relative path is relative to the temporary work directory for this web module.

## session-properties

Specifies session properties.

### Subelements

The following table describes subelements for the `session-properties` element. The left column lists the subelement name, the middle column indicates the requirement rule, and the right column describes what the element does.

### `session-properties` subelements

Element	Required	Description
<code>property</code>	zero or more	Specifies a property, which has a name and a value.

### Attributes

none

## Properties

The following table describes properties for the `session-properties` element. The left column lists the property name, the middle column indicates the default value, and the right column describes what the property does.

### `session-properties` properties

Property Name	Default Value	Description
<code>timeoutSeconds</code>	600	Specifies the default maximum inactive interval (in seconds) for all sessions created in this web module. If set to 0 or less, sessions in this web module never expire.  If a <code>session-timeout</code> element is specified in the <code>web.xml</code> file, the <code>session-timeout</code> value overrides any <code>timeoutSeconds</code> value. If neither <code>session-timeout</code> nor <code>timeoutSeconds</code> is specified, the <code>timeoutSeconds</code> default is used.  Note that the <code>session-timeout</code> element in <code>web.xml</code> is specified in minutes, not seconds.
<code>enableCookies</code>	true	Uses cookies for session tracking if set to true.
<code>enableURLRewriting</code>	true	Enables URL rewriting. This provides session tracking via URL rewriting when the browser does not accept cookies. You must also use an <code>encodeURL</code> or <code>encodeRedirectURL</code> call in the servlet or JSP.
<code>idLengthBytes</code>	128	Specifies the number of bytes in this web module's session ID.

## cookie-properties

Specifies session cookie properties.

### Subelements

The following table describes subelements for the `cookie-properties` element. The left column lists the subelement name, the middle column indicates the requirement rule, and the right column describes what the element does.

### `cookie-properties` subelements

Element	Required	Description
<code>property</code>	zero or more	Specifies a property, which has a name and a value.

**Attributes**

none

**Properties**

The following table describes properties for the `cookie-properties` element. The left column lists the property name, the middle column indicates the default value, and the right column describes what the property does.

`cookie-properties` **properties**

Property Name	Default Value	Description
<code>cookieName</code>	JSESSIONID	Specifies the name of the cookie used for session tracking.
<code>cookiePath</code>	Context path at which the web module is installed.	Specifies the pathname that is set when the cookie is created. The browser sends the cookie if the pathname for the request contains this pathname. If set to / (slash), the browser sends cookies to all URLs served by the Sun ONE Application Server. You can set the path to a narrower mapping to limit the request URLs to which the browser sends cookies.
<code>cookieMaxAgeSeconds</code>	-1	Specifies the expiration time (in seconds) after which the browser expires the cookie.
<code>cookieDomain</code>	(unset)	Specifies the domain for which the cookie is valid.
<code>cookieComment</code>	Sun ONE Application Server Session Tracking Cookie	Specifies the comment that identifies the session tracking cookie in the cookie file. Applications can provide a more specific comment for the cookie.

## Reference Elements

Reference elements are as follows:

- `resource-env-ref`
- `resource-env-ref-name`
- `resource-ref`
- `res-ref-name`
- `default-resource-principal`
- `name`

- password
- ejb-ref
- ejb-ref-name
- jndi-name

## resource-env-ref

Maps the `res-ref-name` in the corresponding J2EE `web.xml` file `resource-env-ref` entry to the absolute `jndi-name` of a resource.

### Subelements

The following table describes subelements for the `resource-env-ref` element. The left column lists the subelement name, the middle column indicates the requirement rule, and the right column describes what the element does.

resource-env-ref subelements		
Element	Required	Description
<code>resource-env-ref-name</code>	only one	Specifies the <code>res-ref-name</code> in the corresponding J2EE <code>web.xml</code> file <code>resource-env-ref</code> entry.
<code>jndi-name</code>	only one	Specifies the absolute <code>jndi-name</code> of a resource.

### Attributes

none

## resource-env-ref-name

Contains data that specifies the `res-ref-name` in the corresponding J2EE `web.xml` file `resource-env-ref` entry.

### Subelements

none

### Attributes

none



## resource-ref

Maps the `res-ref-name` in the corresponding J2EE `web.xml` file `resource-ref` entry to the absolute `jndi-name` of a resource.

### Subelements

The following table describes subelements for the `resource-ref` element. The left column lists the subelement name, the middle column indicates the requirement rule, and the right column describes what the element does.

`resource-ref` subelements

Element	Required	Description
<code>res-ref-name</code>	only one	Specifies the <code>res-ref-name</code> in the corresponding J2EE <code>web.xml</code> file <code>resource-ref</code> entry.
<code>jndi-name</code>	only one	Specifies the absolute <code>jndi-name</code> of a resource.
<code>default-resource-principal</code>	zero or one	Specifies the default principal (user) for the resource.

### Attributes

none

## res-ref-name

Contains data that specifies the `res-ref-name` in the corresponding J2EE `web.xml` file `resource-ref` entry.

### Subelements

none

### Attributes

none

## default-resource-principal

Specifies the default principal (user) for the resource.

If this element is used in conjunction with a JMS Connection Factory resource, the `name` and `password` subelements must be valid entries in Sun ONE Message Queue's broker user repository. See the "Security Management" chapter in the *Sun ONE Message Queue Administrator's Guide* for details.

### Subelements

The following table describes subelements for the `default-resource-principal` element. The left column lists the subelement name, the middle column indicates the requirement rule, and the right column describes what the element does.

`default-resource-principal` subelements

Element	Required	Description
<code>name</code>	only one	Contains the name of the principal.
<code>password</code>	only one	Contains the password for the principal.

### Attributes

none

### name

Contains data that specifies the name of the principal.

### Subelements

none

### Attributes

none

### password

Contains data that specifies the password for the principal.

### Subelements

none

### Attributes

none

## ejb-ref

Maps the `ejb-ref-name` in the corresponding J2EE `ejb-jar.xml` file `ejb-ref` entry to the absolute `jndi-name` of a resource.

### Subelements

The following table describes subelements for the `ejb-ref` element. The left column lists the subelement name, the middle column indicates the requirement rule, and the right column describes what the element does.

`ejb-ref` subelements

Element	Required	Description
<code>ejb-ref-name</code>	only one	Specifies the <code>ejb-ref-name</code> in the corresponding J2EE <code>ejb-jar.xml</code> file <code>ejb-ref</code> entry.
<code>jndi-name</code>	only one	Specifies the absolute <code>jndi-name</code> of a resource.

### Attributes

none

## ejb-ref-name

Contains data that specifies the `ejb-ref-name` in the corresponding J2EE `ejb-jar.xml` file `ejb-ref` entry.

### Subelements

none

### Attributes

none

## jndi-name

Contains data that specifies the absolute `jndi-name` of a URL resource or a resource in the `server.xml` file.

---

**NOTE** To avoid collisions with names of other enterprise resources in JNDI, and to avoid portability problems, all names in a Sun ONE Application Server application should begin with the string `java:comp/env`.

---

**Subelements**

none

**Attributes**

none

## Caching Elements

For details about response caching as it pertains to servlets, see “Caching Servlet Results,” on page 45. For details about JSP caching, see “JSP Caching,” on page 56.

Caching elements are as follows:

- `cache`
- `cache-helper`
- `default-helper`
- `cache-mapping`
- `url-pattern`
- `timeout`
- `http-method`
- `key-field`
- `constraint-field`
- `value`

### **cache**

Configures caching for web application components.

**Subelements**

The following table describes subelements for the `cache` element. The left column lists the subelement name, the middle column indicates the requirement rule, and the right column describes what the element does.

## cache subelements

Element	Required	Description
cache-helper	zero or more	Specifies a custom class that implements the CacheHelper interface.
default-helper	zero or one	Allows you to change the properties of the default, built-in cache-helper class.
property	zero or more	Specifies a cache property, which has a name and a value.
cache-mapping	zero or more	Maps a URL pattern or a servlet name to its cacheability constraints.

**Attributes**

The following table describes attributes for the `cache` element. The left column lists the attribute name, the middle column indicates the default value, and the right column describes what the attribute does.

## cache attributes

Attribute	Default Value	Description
max-entries	4096	(optional) Specifies the maximum number of entries the cache can contain. Must be a positive integer.
timeout-in-seconds	30	(optional) Specifies the maximum amount of time in seconds that an entry can remain in the cache after it is created or refreshed. Can be overridden by a <code>timeout</code> element.
enabled	false	(optional) Determines whether servlet and JSP caching is enabled. Legal values are <code>on</code> , <code>off</code> , <code>yes</code> , <code>no</code> , <code>1</code> , <code>0</code> , <code>true</code> , <code>false</code> .

**Properties**

The following table describes properties for the `cache` element. The left column lists the property name, the middle column indicates the default value, and the right column describes what the property does.

## cache properties

Property	Default Value	Description
cacheClassName	com.sun.appserv.web.cache.LruCache	Specifies the fully qualified name of the class that implements the cache functionality. The “cacheClassName values” table below lists possible values.
MultiLRUSegmentSize	4096	Specifies the number of entries in a segment of the cache table that should have its own LRU (least recently used) list. Applicable only if cacheClassName is set to com.sun.appserv.web.cache.MultiLruCache.
MaxSize	unlimited; Long.MAX_VALUE	Specifies an upper bound on the cache memory size in bytes (KB or MB units). Example values are 32 KB or 2 MB. Applicable only if cacheClassName is set to com.sun.appserv.web.cache.BoundedMultiLruCache.

**Cache Class Names**

The following table lists possible values of the `cacheClassName` property. The left column lists the value, and the right column describes the kind of cache the value specifies.

## cacheClassName values

Value	Description
com.sun.appserv.web.cache.LruCache	A bounded cache with an LRU (least recently used) cache replacement policy.
com.sun.appserv.web.cache.BaseCache	An unbounded cache suitable if the maximum number of entries is known.
com.sun.appserv.web.cache.MultiLruCache	A cache suitable for a large number of entries (>4096). Uses the <code>MultiLRUSegmentSize</code> property.
com.sun.appserv.web.cache.BoundedMultiLruCache	A cache suitable for limiting the cache size by memory rather than number of entries. Uses the <code>MaxSize</code> property.

## cache-helper

Specifies a class that implements the `CacheHelper` interface. For details, see “CacheHelper Interface,” on page 48.

### Subelements

The following table describes subelements for the `cache-helper` element. The left column lists the subelement name, the middle column indicates the requirement rule, and the right column describes what the element does.

cache-helper subelements

Element	Required	Description
property	zero or more	Specifies a property, which has a name and a value.

### Attributes

The following table describes attributes for the `cache-helper` element. The left column lists the attribute name, the middle column indicates the default value, and the right column describes what the attribute does.

cache-helper attributes

Attribute	Default Value	Description
name	default	Specifies a unique name for the helper class, which is referenced in the <code>cache-mapping</code> element.
class-name	none	Specifies the fully qualified class name of the cache helper, which must implement the <code>com.sun.appserv.web.CacheHelper</code> interface.

## default-helper

Allows you to change the properties of the built-in `default` `cache-helper` class.

### Subelements

The following table describes subelements for the `default-helper` element. The left column lists the subelement name, the middle column indicates the requirement rule, and the right column describes what the element does.

## default-helper subelements

Element	Required	Description
property	zero or more	Specifies a property, which has a name and a value.

**Attributes**

none

**Properties**

The following table describes properties for the `default-helper` element. The left column lists the property name, the middle column indicates the default value, and the right column describes what the property does.

## default-helper properties

Property	Default Value	Description
<code>cacheKeyGeneratorAttrName</code>	Uses the built-in default <code>cache-helper</code> key generation, which concatenates the servlet path with <code>key-field</code> values, if any.	The caching engine looks in the <code>ServletContext</code> for an attribute with a name equal to the value specified for this property to determine whether a customized <code>CacheKeyGenerator</code> implementation is used. An application may provide a customized key generator rather than using the default helper.  See “CacheKeyGenerator Interface,” on page 50.

**cache-mapping**

Maps a URL pattern or a servlet name to its cacheability constraints.

**Subelements**

The following table describes subelements for the `cache-mapping` element. The left column lists the subelement name, the middle column indicates the requirement rule, and the right column describes what the element does.



## cache-mapping subelements

Element	Required	Description
servlet-name	requires one servlet-name or url-pattern	Contains the name of a servlet.
url-pattern	requires one servlet-name or url-pattern	Contains a servlet URL pattern for which caching is enabled.
cache-helper-ref	required if timeout, refresh-field, http-method, key-field, and constraint-field are not used	Contains the name of the cache-helper used by the parent cache-mapping element.
timeout	zero or one if cache-helper-ref is not used	Contains the cache-mapping specific maximum amount of time in seconds that an entry can remain in the cache after it is created or refreshed.
refresh-field	zero or one if cache-helper-ref is not used	Specifies a field that gives the application component a programmatic way to refresh a cached entry.
http-method	zero or more if cache-helper-ref is not used	Contains an HTTP method that is eligible for caching.
key-field	zero or more if cache-helper-ref is not used	Specifies a component of the key used to look up and extract cache entries.
constraint-field	zero or more if cache-helper-ref is not used	Specifies a cacheability constraint for the given url-pattern or servlet-name.

**Attributes**

none

## url-pattern

Contains data that specifies a servlet URL pattern for which caching is enabled. See the Servlet 2.3 specification section SRV. 11.2 for applicable patterns.

### Subelements

none

### Attributes

none

## cache-helper-ref

Contains data that specifies the name of the `cache-helper` used by the parent `cache-mapping` element.

### Subelements

none

### Attributes

none

## timeout

Contains data that specifies the `cache-mapping` specific maximum amount of time in seconds that an entry can remain in the cache after it is created or refreshed. If not specified, the default is the value of the `timeout` attribute of the `cache` element.

### Subelements

none

### Attributes

The following table describes attributes for the `timeout` element. The left column lists the attribute name, the middle column indicates the default value, and the right column describes what the attribute does.

timeout attributes

Attribute	Default Value	Description
name	none	Specifies the timeout input parameter, whose value is interpreted in seconds. The field's type must be <code>java.lang.Long</code> or <code>java.lang.Integer</code> .

timeout attributes *(Continued)*

Attribute	Default Value	Description
scope	request.attribute	(optional) Specifies the scope in which the input parameter can be present. Allowed values are context.attribute, request.header, request.parameter, request.cookie, request.attribute, and session.attribute.

**refresh-field**

Specifies a field that gives the application component a programmatic way to refresh a cached entry.

**Subelements**

none

**Attributes**

The following table describes attributes for the `refresh-field` element. The left column lists the attribute name, the middle column indicates the default value, and the right column describes what the attribute does.

## refresh-field attributes

Attribute	Default Value	Description
name	none	Specifies the input parameter name.
scope	request.parameter	(optional) Specifies the scope in which the input parameter can be present. Allowed values are context.attribute, request.header, request.parameter, request.cookie, session.id, and session.attribute.

**http-method**

Contains data that specifies an HTTP method that is eligible for caching. The default is `GET`.

**Subelements**

none

**Attributes**

none

## key-field

Specifies a component of the key used to look up and extract cache entries. The web container looks for the named parameter, or field, in the specified scope.

If this element is not present, the web container uses the Servlet Path (the path section that corresponds to the servlet mapping that activated the current request). See the Servlet 2.3 specification, section SRV 4.4, for details on the Servlet Path.

### Subelements

none

### Attributes

The following table describes attributes for the `key-field` element. The left column lists the attribute name, the middle column indicates the default value, and the right column describes what the attribute does.

`key-field` attributes

Attribute	Default Value	Description
<code>name</code>	<code>none</code>	Specifies the input parameter name.
<code>scope</code>	<code>request.parameter</code>	(optional) Specifies the scope in which the input parameter can be present. Allowed values are <code>context.attribute</code> , <code>request.header</code> , <code>request.parameter</code> , <code>request.cookie</code> , <code>session.id</code> , and <code>session.attribute</code> .

## constraint-field

Specifies a cacheability constraint for the given `url-pattern` or `servlet-name`.

All `constraint-field` constraints must pass for a response to be cached. If there are `value` constraints, at least one of them must pass.

### Subelements

The following table describes subelements for the `constraint-field` element. The left column lists the subelement name, the middle column indicates the requirement rule, and the right column describes what the element does.

`constraint-field` subelements

Element	Required	Description
<code>value</code>	zero or more	Contains a value to be matched to the input parameter value.

### Attributes

The following table describes attributes for the `constraint-field` element. The left column lists the attribute name, the middle column indicates the default value, and the right column describes what the attribute does.

`constraint-field` attributes

Attribute	Default Value	Description
<code>name</code>	<code>none</code>	Specifies the input parameter name.
<code>scope</code>	<code>request.parameter</code>	(optional) Specifies the scope in which the input parameter can be present. Allowed values are <code>context.attribute</code> , <code>request.header</code> , <code>request.parameter</code> , <code>request.cookie</code> , <code>request.attribute</code> , and <code>session.attribute</code> .
<code>cache-on-match</code>	<code>true</code>	(optional) If <code>true</code> , caches the response if matching succeeds. Overrides the same attribute in a <code>value</code> subelement.
<code>cache-on-match-failure</code>	<code>false</code>	(optional) If <code>true</code> , caches the response if matching fails. Overrides the same attribute in a <code>value</code> subelement.

### value

Contains data that specifies a value to be matched to the input parameter value. The matching is case sensitive. For example:

```
<value match-expr="in-range">1-60</value>
```

### Subelements

`none`

### Attributes

The following table describes attributes for the `value` element. The left column lists the attribute name, the middle column indicates the default value, and the right column describes what the attribute does.

## value attributes

Attribute	Default Value	Description
match-expr	equals	(optional) Specifies the type of comparison performed with the value. Allowed values are equals, not-equals, greater, lesser, and in-range.  If match-expr is greater or lesser, the value must be a number. If match-expr is in-range, the value must be of the form $n1-n2$ , where $n1$ and $n2$ are numbers.
cache-on-match	true	(optional) If true, caches the response if matching succeeds.
cache-on-match-failure	false	(optional) If true, caches the response if matching fails.

## ClassLoader Elements

ClassLoader elements are as follows:

- class-loader

### class-loader

Configures the classloader for the web module.

#### Subelements

none

#### Attributes

The following table describes attributes for the `class-loader` element. The left column lists the attribute name, the middle column indicates the default value, and the right column describes what the attribute does.

## class-loader attributes

Attribute	Default Value	Description
extra-class-path	null	(optional) Specifies additional classpath settings for this web module.

*class-loader attributes (Continued)*

Attribute	Default Value	Description
<code>delegate</code>	<code>false</code>	<p>(optional) If <code>true</code>, the web module follows the standard classloader delegation model and delegates to its parent classloader first before looking in the local classloader. If <code>false</code>, the web module follows the delegation model specified in the Servlet specification and looks in its classloader before looking in the parent classloader.</p> <p>For a web component of a web service, you must set this value to <code>true</code>.</p> <p>Legal values are <code>on</code>, <code>off</code>, <code>yes</code>, <code>no</code>, <code>1</code>, <code>0</code>, <code>true</code>, <code>false</code>.</p>

## JSP Elements

JSP elements are as follows:

- `jsp-config`

### **jsp-config**

Specifies JSP configuration information.

#### **Subelements**

The following table describes subelements for the `jsp-config` element. The left column lists the subelement name, the middle column indicates the requirement rule, and the right column describes what the element does.

#### *jsp-config* subelements

Element	Required	Description
<code>property</code>	zero or more	Specifies a property.

#### **Attributes**

none

## Properties

The following table describes properties for the `jsp-config` element. The left column lists the property name, the middle column indicates the default value, and the right column describes what the property does.

### jsp-config properties

Property Name	Default Value	Description
<code>ieClassId</code>	<code>clsid:8AD9C840-044E-11D1-B3E9-00805F499D93</code>	The Java plugin COM class ID for Internet Explorer. Used by the <code>&lt;jsp:plugin&gt;</code> tags.
<code>javaCompilerPlugin</code>	The internal JDK compiler ( <code>javac</code> )	The fully qualified class name of the Java compiler plug-in to be used. Not needed for the default compiler.  For example, to use the <code>jikes</code> compiler for JSP pages, set the <code>javaCompilerPlugin</code> property to <code>org.apache.jasper.compiler.JikesJavaCompiler</code> , then set the <code>javaCompilerPath</code> property to point to the <code>jikes</code> executable.
<code>javaCompilerPath</code>	none	Specifies the path to the executable of an out-of-process Java compiler such as <code>jikes</code> . Ignored for the default compiler. Needed only if the <code>javaCompilerPlugin</code> property is specified.
<code>javaEncoding</code>	UTF8	Specifies the encoding for the generated Java servlet. This encoding is passed to the Java compiler used to compile the servlet as well. By default, the web container tries to use UTF8. If that fails, it tries to use the <code>javaEncoding</code> value.  For encodings you can use, see:  <a href="http://java.sun.com/j2se/1.4/docs/guide/intl/encoding.doc.html">http://java.sun.com/j2se/1.4/docs/guide/intl/encoding.doc.html</a>
<code>classdebuginfo</code>	false	Specifies whether the generated Java servlets should be compiled with the debug option set ( <code>-g</code> for <code>javac</code> ).
<code>keepgenerated</code>	true	If set to <code>true</code> , keeps the generated Java files. If <code>false</code> , deletes the Java files.
<code>largefile</code>	false	If set to <code>true</code> , static HTML is stored in a separate data file when a JSP is compiled. This is useful when a JSP is very large, because it minimizes the size of the generated servlet.



### jsp-config properties

Property Name	Default Value	Description
mappedfile	false	If set to <code>true</code> , generates separate <code>write</code> calls for each HTML line and comments that describe the location of each line in the JSP file. By default, all adjacent <code>write</code> calls are combined and no location comments are generated.
scratchdir	The default work directory for the web application	The working directory created for storing all the generated code.
reload-interval	0	Specifies the frequency (in seconds) at which JSP files are checked for modifications. Setting this value to 0 checks JSPs for modifications on every request. Setting this value to -1 disables checks for JSP modifications and JSP recompilation.

## Internationalization Elements

Internationalization elements are as follows:

- `locale-charset-info`
- `locale-charset-map`
- `parameter-encoding`

### locale-charset-info

Specifies information about the application's internationalization settings.

#### Subelements

The following table describes subelements for the `locale-charset-info` element. The left column lists the subelement name, the middle column indicates the requirement rule, and the right column describes what the element does.

#### locale-charset-info subelements

Element	Required	Description
<code>locale-charset-map</code>	one or more	Maps a locale and an agent to a character set.
<code>parameter-encoding</code>	zero or one	Determines how the web container decodes parameters from forms for this web application according to a hidden field value.

**Attributes**

The following table describes attributes for the `locale-charset-info` element. The left column lists the attribute name, the middle column indicates the default value, and the right column describes what the attribute does.

`locale-charset-info` attributes

Attribute	Default Value	Description
<code>default-locale</code>	none	Specifies the default locale.

**locale-charset-map**

Maps locales and agents to character sets.

For encodings you can use, see:

<http://java.sun.com/j2se/1.4/docs/guide/intl/encoding.doc.html>

**Subelements**

The following table describes subelements for the `locale-charset-map` element. The left column lists the subelement name, the middle column indicates the requirement rule, and the right column describes what the element does.

`locale-charset-map` subelements

Element	Required	Description
<code>description</code>	zero or one	Specifies an optional text description of a mapping.

**Attributes**

The following table describes attributes for the `locale-charset-map` element. The left column lists the attribute name, the middle column indicates the default value, and the right column describes what the attribute does.

`locale-charset-map` attributes

Attribute	Default Value	Description
<code>locale</code>	none	Specifies the locale name.

locale-charset-map attributes *(Continued)*

Attribute	Default Value	Description
agent	none	(optional) Specifies the type of client that interacts with the application server. For a given locale, different agents may have different preferred character sets. The value of this attribute must exactly match the value of the <code>user-agent</code> HTTP request header sent by the client. See the “example agent attribute values” table for more information.
charset	none	Specifies the character set.

**Example Agents**

The following table specifies example `agent` attribute values. The left column lists the agent, and the right column lists the corresponding attribute value.

## example agent attribute values

Agent	user-agent Header and agent Attribute Value
Internet Explorer 5.00 for Windows 2000	Mozilla/4.0 (compatible; MSIE 5.01; Windows NT 5.0)
Netscape 4.7.7 for Windows 2000	Mozilla/4.77 [en] (Windows NT 5.0; U)
Netscape 4.7 for Solaris	Mozilla/4.7 [en] (X11; u; Sun OS 5.6 sun4u)

**parameter-encoding**

Specifies a hidden field that determines the character encoding the web container uses to decode parameters for `request.getParameter` calls when the `charset` is not set in the request's `content-type`.

For encodings you can use, see:

<http://java.sun.com/j2se/1.4/docs/guide/intl/encoding.doc.html>

**Subelements**

none

**Attributes**

The following table describes attributes for the `parameter-encoding` element. The left column lists the attribute name, the middle column indicates the default value, and the right column describes what the attribute does.

## parameter-encoding attributes

Attribute	Default Value	Description
form-hint-field	none	The name of the hidden field in the form that specifies the parameter encoding.

## Sample Web Module XML Files

This section includes the following:

- Sample web.xml File
- Sample sun-web.xml File

### Sample web.xml File

```
<?xml version="1.0" encoding="UTF-8"?>
<!DOCTYPE web-app PUBLIC "-//Sun Microsystems, Inc.//DTD Web
Application 2.3//EN"
'http://java.sun.com/j2ee/dtds/web-app_2_2.dtd'>
<web-app>
  <display-name>webapps-simple</display-name>
  <description>
    The jakarta-tomcat-4.0.3 sample apps ports over to S1AS.
  </description>
  <distributable></distributable>
  <servlet>
    <servlet-name>HelloWorldExample</servlet-name>
    <servlet-class>
      samples.webapps.simple.servlet.HelloWorldExample
    </servlet-class>
  </servlet>
  <servlet>
    <servlet-name>RequestHeaderExample</servlet-name>
```

```
<servlet-class>
    samples.webapps.simple.servlet.RequestHeaderExample
</servlet-class>
</servlet>
<servlet>
    <servlet-name>SnoopServlet</servlet-name>
    <servlet-class>
        samples.webapps.simple.servlet.SnoopServlet
    </servlet-class>
</servlet>
<servlet>
    <servlet-name>servletToJsp</servlet-name>
    <servlet-class>
        samples.webapps.simple.servlet.servletToJsp
    </servlet-class>
</servlet>
<servlet>
    <servlet-name>RequestInfoExample</servlet-name>
    <servlet-class>
        samples.webapps.simple.servlet.RequestInfoExample
    </servlet-class>
</servlet>
<servlet>
    <servlet-name>SessionExample</servlet-name>
    <servlet-class>
        samples.webapps.simple.servlet.SessionExample
    </servlet-class>
</servlet>
<servlet>
    <servlet-name>CookieExample</servlet-name>
    <servlet-class>
```

```
        samples.webapps.simple.servlet.CookieExample
    </servlet-class>
</servlet>
<servlet>
    <servlet-name>RequestParamExample</servlet-name>
    <servlet-class>
        samples.webapps.simple.servlet.RequestParamExample
    </servlet-class>
</servlet>
<servlet>
    <servlet-name>SendMailServlet</servlet-name>
    <servlet-class>
        samples.webapps.simple.servlet.SendMailServlet
    </servlet-class>
</servlet>
<servlet>
    <servlet-name>JndiServlet</servlet-name>
    <servlet-class>
        samples.webapps.simple.servlet.JndiServlet
    </servlet-class>
</servlet>
<servlet-mapping>
    <servlet-name>HelloWorldExample</servlet-name>
    <url-pattern>/helloworld</url-pattern>
</servlet-mapping>
<servlet-mapping>
    <servlet-name>RequestHeaderExample</servlet-name>
    <url-pattern>/requestheader</url-pattern>
</servlet-mapping>
<servlet-mapping>
    <servlet-name>SnoopServlet</servlet-name>
```

```
        <url-pattern>/snoop</url-pattern>
</servlet-mapping>
<servlet-mapping>
    <servlet-name>servletToJsp</servlet-name>
    <url-pattern>/servletToJsp</url-pattern>
</servlet-mapping>
<servlet-mapping>
    <servlet-name>RequestInfoExample</servlet-name>
    <url-pattern>/requestinfo</url-pattern>
</servlet-mapping>
<servlet-mapping>
    <servlet-name>SessionExample</servlet-name>
    <url-pattern>/session</url-pattern>
</servlet-mapping>
<servlet-mapping>
    <servlet-name>CookieExample</servlet-name>
    <url-pattern>/cookie</url-pattern>
</servlet-mapping>
<servlet-mapping>
    <servlet-name>RequestParamExample</servlet-name>
    <url-pattern>/requestparam</url-pattern>
</servlet-mapping>
<servlet-mapping>
    <servlet-name>SendMailServlet</servlet-name>
    <url-pattern>/SendMailServlet</url-pattern>
</servlet-mapping>
<servlet-mapping>
    <servlet-name>JndiServlet</servlet-name>
    <url-pattern>/JndiServlet</url-pattern>
</servlet-mapping>
<welcome-file-list>
```

```

        <welcome-file>index.html</welcome-file>
    </welcome-file-list>
    <taglib>
        <taglib-uri>
            http://java.apache.org/tomcat/examples-taglib
        </taglib-uri>
        <taglib-location>
            /WEB-INF/tlds/example-taglib.tld
        </taglib-location>
    </taglib>
    <resource-ref>
        <res-ref-name>mail/Session</res-ref-name>
        <res-type>javax.mail.Session</res-type>
        <res-auth>Container</res-auth>
    </resource-ref>
    <security-constraint>
        <web-resource-collection>
            <web-resource-name>Protected Area</web-resource-name>
<!-- Define the context-relative URL(s) to be protected -->
            <url-pattern>/jsp/security/protected/*</url-pattern>
<!-- If you list http methods, only those methods are protected -->
            <http-method>DELETE</http-method>
            <http-method>GET</http-method>
            <http-method>POST</http-method>
            <http-method>PUT</http-method>
        </web-resource-collection>
        <auth-constraint>
<!-- Anyone with one of the listed roles may access this area -->
            <role-name>tomcat</role-name>
            <role-name>role1</role-name>
        </auth-constraint>
    </security-constraint>

```



```
</security-constraint>
<!-- Environment entry examples -->
<env-entry>
  <description>
    The maximum number of tax exemptions allowed to be set.
  </description>
  <env-entry-name>maxExemptions</env-entry-name>
  <env-entry-value>15</env-entry-value>
  <env-entry-type>java.lang.Integer</env-entry-type>
</env-entry>
<env-entry>
  <env-entry-name>minExemptions</env-entry-name>
  <env-entry-value>1</env-entry-value>
  <env-entry-type>java.lang.Integer</env-entry-type>
</env-entry>
<env-entry>
  <env-entry-name>foo/name1</env-entry-name>
  <env-entry-value>value1</env-entry-value>
  <env-entry-type>java.lang.String</env-entry-type>
</env-entry>
<env-entry>
  <env-entry-name>foo/bar/name2</env-entry-name>
  <env-entry-value>true</env-entry-value>
  <env-entry-type>java.lang.Boolean</env-entry-type>
</env-entry>
<env-entry>
  <env-entry-name>name3</env-entry-name>
  <env-entry-value>1</env-entry-value>
  <env-entry-type>java.lang.Integer</env-entry-type>
</env-entry>
<env-entry>
```

```
<env-entry-name>foo/name4</env-entry-name>
<env-entry-value>10</env-entry-value>
<env-entry-type>java.lang.Integer</env-entry-type>
</env-entry>
</web-app>
```

## Sample sun-web.xml File

```
<?xml version="1.0" encoding="UTF-8"?>
<!DOCTYPE sun-web-app PUBLIC "-//Sun Microsystems, Inc.//DTD Sun ONE
Application Server 7.0 Servlet 2.3//EN"
'http://www.sun.com/software/sunone/appserver/dtds/sun-web-app_2_3-
0.dtd'>
<sun-web-app>
  <session-config>
    <session-manager/>
  </session-config>
  <resource-ref>
    <res-ref-name>mail/Session</res-ref-name>
    <jndi-name>mail/Session</jndi-name>
  </resource-ref>
  <jsp-config/>
</sun-web-app>
```

# Using Server-Parsed HTML

HTML files can contain tags that are executed on the server. In addition to supporting the standard server-side tags, Sun ONE Application Server 7 allows you to embed servlets and define your own server-side tags.

You can create custom server-parsed HTML tags. For more information, see the *Sun ONE Application Server NSAPI Developer's Guide*.

For security, server-parsed HTML tags depend on the server's security configuration. For more information, see "Security for SHTML and CGI," on page 81 and the *Sun ONE Application Server Administrator's Guide to Security*.

This chapter has the following sections:

- Server-Side HTML and J2EE Web Applications
- Enabling Server-Side HTML
- Using Server-Side HTML Commands
- Embedding Servlets
- Time Formats

## Server-Side HTML and J2EE Web Applications

In Sun ONE Application Server, server-parsed HTML cannot interoperate with J2EE web applications. Specifically:

- Do not place server-parsed HTML within web application context roots.
- Do not include the output of server-parsed HTML in servlets or JSPs.
- Do not forward requests to server-parsed HTML from servlets or JSPs.

- You cannot apply J2EE `security-constraint` and `filter-mapping` features to server-parsed HTML.

## Enabling Server-Side HTML

To enable server-side HTML:

1. Open the HTTP Server component under your server instance in the Administration interface.
2. Go to the Virtual Servers page.
3. Click on the name of the virtual server for which you are enabling server-side HTML.
4. Click on the HTTP/HTML tab.
5. Click on the Parse HTML option.
6. Choose a resource for which the server will parse HTML.

Choose the virtual server or a specific directory within the virtual server.

If you choose a directory, the server will parse HTML only when the server receives a URL for that directory or any file in that directory.

7. Choose whether to activate server-parsed HTML.

You can activate for HTML files but not the `exec` tag, or for HTML files and the `exec` tag, which allows HTML files to execute other programs on the server.

8. Choose which files to parse.

You can choose whether to parse only files with the `.shtml` extension, or all HTML files, which slows performance. If you are using UNIX, you can also choose to parse UNIX files with the `execute` permission turned on, though that can be unreliable.

9. Click on the OK button.
10. Go to the server instance page and select the Apply Changes button.

When you activate parsing, you need to be sure that the following directives are added to your `init.conf` file (note that native threads are turned off):

```
Init funcs="shtml_init,shtml_send" shlib="install_dir/bin/Shtml.dll"
NativeThread="no" fn="load-modules"
```

Note that you must set `NativeThread="no"` for Sun ONE Application Server 7. In addition, these functions now originate from `Shtml.dll` (or `libShtml.so` on UNIX), which is located in *install\_dir*/bin for Windows (and *install\_dir*/lib for UNIX).

In addition, be sure that the following directive is added to your `obj.conf` file:

```
<Object name="default">
...
...
Service fn="shtml_send" type="magnus-internal/parsed-html" method="(GET|HEAD)"
...
</Object>
```

## Using Server-Side HTML Commands

This section describes the HTML commands for including server-parsed tags in HTML files. These commands are embedded into HTML files, which are processed by the `obj.conf` file's `parse-html` function.

The server replaces each command with data determined by the command and its attributes. The format for a command is:

```
<!--#command attribute1 attribute2 <Body>... -->
```

The format for each `attribute` is a name-value pair such as:

```
name=" value"
```

Commands and attribute names should be in lower case.

The commands are “hidden” within HTML comments so they are ignored if not parsed by the server. The standard server-side commands are:

- `config`
- `include`
- `echo`
- `fsize`

- `flastmod`
- `exec`

## config

The `config` command initializes the format for other commands.

- The `errmsg` attribute defines a message sent to the client when an error occurs while parsing the file. This error is also logged in the server log file.
- The `timefmt` attribute determines the format of the date for the `flastmod` command. It uses the same format characters as the `util_strftime` function. The default time format is: "%A, %d-%b-%y %T".

Refer to “Time Formats,” on page 137 for details about time formats.

- The `sizefmt` attribute determines the format of the file size for the `fsize` command. It can have one of these values:
  - `bytes` to report file size as a whole number in the format 12,345,678.
  - `abbrev` (the default) to report file size as a number of KB or MB.

Example:

```
<!--#config timefmt="%r %a %b %e, %Y" sizefmt="abbrev"-->
```

This sets the date format to a value such as 08:23:15 AM Wed Apr 15, 1996, and the file size format to the number of KB or MB of characters used by the file.

## include

The `include` command inserts a file into the parsed file. You can nest files by including another parsed file, which then includes another file, and so on. The client requesting the parsed document must also have access to the included file if your server uses access control for the directories where they reside.

In Sun ONE Application Server 7, you can use the `include` command with the `virtual` attribute to include a CGI program file. You must also use an `exec` command to execute the CGI program.

- The `virtual` attribute is the URI of a file on the server.
- The `file` attribute is a relative path name from the current directory. It cannot contain elements such as `../` and it cannot be an absolute path.

Example:

```
<!--#include file="bottle.gif"-->
```

## echo

The `echo` command inserts the value of an environment variable. The `var` attribute specifies the environment variable to insert. If the variable is not found, “(none)” is inserted. For a list of environment variables, see the section “Environment Variables in Server-Side HTML Commands,” on page 136.

Example:

```
<!--#echo var="DATE_GMT"-->
```

## fsize

The `fsize` command sends the size of a file. The attributes are the same as those for the `include` command (`virtual` and `file`). The file size format is determined by the `sizefmt` attribute in the `config` command.

Example:

```
<!--#fsize file="bottle.gif"-->
```

## flastmod

The `flastmod` command prints the date a file was last modified. The attributes are the same as those for the `include` command (`virtual` and `file`). The date format is determined by the `timefmt` attribute in the `config` command.

Example:

```
<!--#flastmod file="bottle.gif"-->
```

## exec

The `exec` command runs a shell command or CGI program.

- The `cmd` attribute (UNIX only) runs a command using `/bin/sh`. You may include any special environment variables in the command.

- The `cgi` attribute runs a CGI program and includes its output in the parsed file.

Example:

```
<!--#exec cgi="workit.pl"-->
```

## Environment Variables in Server-Side HTML Commands

In addition to the normal set of environment variables used in CGI, you may include the following variables in your parsed commands:

- `DOCUMENT_NAME`  
is the file name of the parsed file.
- `DOCUMENT_URI`  
is the virtual path to the parsed file (for example, `/shtml/test.shtml`).
- `QUERY_STRING_UNESCAPED`  
is the unescaped version of any search query the client sent with all shell-special characters escaped with the `\` character.
- `DATE_LOCAL`  
is the current date and local time.
- `DATE_GMT`  
is the current date and time expressed in Greenwich Mean Time.
- `LAST_MODIFIED`  
is the date the file was last modified.

## Embedding Servlets

Sun ONE Application Server 7 supports the `<SERVLET>` tag as introduced by Java Web Server. This tag allows you to embed servlet output in an SHTML file. No configuration changes are necessary to enable this behavior. If SSI and servlets are both enabled, the `<SERVLET>` tag is enabled.



The `<SERVLET>` tag syntax is slightly different from that of other SSI commands; it resembles the `<APPLET>` tag syntax:

```
<servlet code=code>
<param name=param1 value=v3>
<param name=param2 value=v4>
.
.
</servlet>
```

The `code` parameter specifies the URI of the servlet, including the web application context root. This URI must match a `url-pattern` subelement of a `servlet-mapping` element in the J2EE deployment descriptor (`web.xml`).

## Time Formats

The following table describes the format strings for dates and times used by server-parsed HTML. The left column lists time format symbols, and the right column explains the meanings of the symbols.

Time formats

Symbol	Meaning
%a	Abbreviated weekday name (3 chars)
%d	Day of month as decimal number (01-31)
%S	Second as decimal number (00-59)
%M	Minute as decimal number (00-59)
%H	Hour in 24-hour format (00-23)
%Y	Year with century, as decimal number, up to 2099
%b	Abbreviated month name (3 chars)
%h	Abbreviated month name (3 chars)
%T	Time "HH:MM:SS"
%X	Time "HH:MM:SS"
%A	Full weekday name
%B	Full month name
%C	"%a %b %e %H:%M:%S %Y"
%c	Date & time "%m/%d/%y %H:%M:%S"

## Time formats

<b>Symbol</b>	<b>Meaning</b>
%D	Date "%m/%d/%Y"
%e	Day of month as decimal number (1-31) without leading zeros
%I	Hour in 12-hour format (01-12)
%j	Day of year as decimal number (001-366)
%k	Hour in 24-hour format (0-23) without leading zeros
%l	Hour in 12-hour format (1-12) without leading zeros
%m	Month as decimal number (01-12)
%n	line feed
%p	A.M./P.M. indicator for 12-hour clock
%R	Time "%H:%M"
%r	Time "%I:%M:%S %p"
%t	tab
%U	Week of year as decimal number, with Sunday as first day of week (00-51)
%w	Weekday as decimal number (0-6; Sunday is 0)
%W	Week of year as decimal number, with Monday as first day of week (00-51)
%x	Date "%m/%d/%Y"
%y	Year without century, as decimal number (00-99)
%%	Percent sign

# Using CGI

Common Gateway Interface (CGI) programs run on the server and generate a response to return to the requesting client. CGI programs can be written in various languages, including C, C++, Perl, and as shell scripts. CGI programs are invoked through URL invocation.

A myriad of information about writing CGI programs is available. A good starting point is “The Common Gateway Interface” at:

<http://hoohoo.ncsa.uiuc.edu/cgi/overview.html>

Sun ONE Application Server complies with the version 1.1 CGI specification.

Since the server starts up a process each time the CGI script or program runs, this is an expensive method of programming the server.

For security, CGI scripts depend on the server’s security configuration. For more information, see “Security for SHTML and CGI,” on page 81 and the *Sun ONE Application Server Administrator’s Guide to Security*.

This chapter includes the following topics:

- CGI and J2EE Web Applications
- Enabling CGI
- Creating Custom Execution Environments for CGI Programs (UNIX only)
- Adding CGI Programs to the Server
- Setting the Priority of a CGI Program
- Windows CGI Programs
- Shell CGI Programs for Windows
- The Query Handler
- Perl CGI Programs

- Global CGI Settings
- CGI Variables

## CGI and J2EE Web Applications

In Sun ONE Application Server, CGI programs cannot interoperate with J2EE web applications. Specifically:

- Do not place CGI programs within web application context roots.
- Do not include the output of CGI programs in servlets or JSPs.
- Do not forward requests to CGI programs from servlets or JSPs.
- You cannot apply J2EE `security-constraint` and `filter-mapping` features to CGI programs.

## Enabling CGI

Sun ONE Application Server provides these ways to identify CGI programs:

- Specifying CGI Directories. The server treats all files in CGI directories as CGI programs.
- Specifying CGI File Extensions. The server treats all files with the specified extensions as CGI programs.

## Specifying CGI Directories

To specify directories that contain CGI programs (and only CGI programs):

1. Create the CGI directory on your computer. This directory doesn't have to be a subdirectory of your document root directory. This is why you must specify a URL prefix in Step 7.
2. Open the HTTP Server component under your server instance in the Administration interface.
3. Go to the Virtual Servers page.
4. Click on the name of the virtual server for which you are specifying a CGI directory.

5. Click on the CGI tab.
6. Click on the CGI Directory option.
7. In the URL Prefix field, type the URL prefix to use for this directory. That is, the text you type appears as the directory for the CGI programs in URLs.

For example, if you type `cgi-bin` as the URL prefix, then all URLs to these CGI programs have the following structure:

```
http://yourserver.domain.com/cgi-bin/program-name
```

---

**NOTE** The URL prefix you specify can be different from the real CGI directory you specify in the previous step.

---

8. In the CGI Directory text field, type the location of the directory as an absolute path.
9. Click on the OK button.
10. Go to the server instance page and select the Apply Changes button.

The server treats all files in these directories as CGI programs.

To remove an existing CGI directory, click that directory's Remove button in the CGI Directory page. To change the URL prefix or CGI directory of an existing directory, click that directory's Edit button.

Copy your CGI programs into the directories you've specified. Remember that any files in those directories are processed as CGI files, so don't put HTML files in your CGI directory.

For each CGI directory, the file `obj.conf` contains a `NameTrans` directive that associates the name `cgi` with each request for a resource in that directory. These directives are automatically added to `obj.conf` when you specify CGI directories in the Administration interface, or you can manually add them to `obj.conf` if desired.

For example, the following instruction interprets all requests for resources in `http://server-name/cgi-local` as requests to invoke CGI programs in the directory `C:/SunServer/docs/mycgi`.

```
NameTrans fn="pfx2dir" from="/cgi-local"
dir="C:/SunServer/docs/mycgi" name="cgi"
```

The `obj.conf` file must contain the following named object:

```
<Object name="cgi">
  ObjectType fn="force-type" type="magnus-internal/cgi"
  Service fn="send-cgi"
</Object>
```

Do not remove this object from `obj.conf`. If you do, the server will never recognize CGI directories, regardless of whether you specify them in the Administration interface or manually add more `NameTrans` directives to `obj.conf`.

## Specifying CGI File Extensions

To instruct the server to treat all files with certain extensions as CGI programs, regardless of which directory they reside in:

1. Open the HTTP Server component under your server instance in the Administration interface.
2. Go to the Virtual Servers page.
3. Click on the name of the virtual server for which you are specifying CGI file types.
4. Click on the CGI tab.
5. Click on the CGI File Type option.
6. From the Editing picker, choose the resource you want this change to apply to.
7. Click the Yes radio button under Activate CGI as a File Type.
8. Click on the OK button.
9. Go to the server instance page and select the Apply Changes button.

The default CGI extensions are `.cgi`, `.bat` and `.exe`.

To change which extensions indicate CGI programs, modify the following line in `mime.types` to specify the desired extensions. Be sure to restart the server after editing `mime.types`.

```
type=magnus-internal/cgi exts=cgi,exe,bat
```

When the server is enabled to treat all files with an appropriate extensions as CGI programs, the `obj.conf` file contains the following Service directive:

```
Service fn="send-cgi" type="magnus-internal/cgi"
```

# Creating Custom Execution Environments for CGI Programs (UNIX only)

Before you can create a custom execution environment, you must install the `suid Cgistub` and run it as root:

1. Log in as the superuser.

```
su
```

2. Create the `private` directory for `Cgistub`:

```
cd instance_dir
```

```
mkdir private
```

3. Copy `Cgistub` to the `private` directory:

```
cd private
```

```
cp install_dir/lib/Cgistub .
```

4. Set the owner of `private` to the server user:

```
chown username .
```

5. Set the permissions on `private`:

```
chmod 500 .
```

6. Set the owner of `Cgistub` to root:

```
chown root Cgistub
```

7. Set the permissions on `Cgistub`:

```
chmod 4711 Cgistub
```

8. You can give each reference to the `send-cgi` function in `obj.conf` a user parameter. For example:

```
Service fn="send-cgi" user="username"
```

You can use variable substitution. For example, in `server.xml`, give a `virtual-server` element the following property subelement:

```
<property name="user" value="username" />
```

This lets you write the `send-cgi` function line in `obj.conf` as follows:

```
Service fn="send-cgi" user="$user"
```

For more information about `send-cgi` and `obj.conf`, see the *Sun ONE Application Server Developer's Guide to NSAPI*. For more information about `server.xml`, see the *Sun ONE Application Server Administrator's Configuration File Reference*.

9. Restart the server so these changes take effect.

---

**NOTE** Installing `Cgistub` in the `instance_dir/private` directory is recommended. If you install it anywhere else, you must specify the path to `Cgistub` in the `init-cgi` function in `init.conf`. For details, see the *Sun ONE Application Server Developer's Guide to NSAPI*.

---

---

**NOTE** It may not be possible to install the `suid Cgistub` program on an NFS mount. If you wish to use an `suid Cgistub`, you must install your server instance to a local file system.

---

`Cgistub` enforces the following security restrictions:

- The user the CGI program executes as must have a `uid` of 100 or greater. This prevents anyone from using `Cgistub` to obtain root access.
- The CGI program must be owned by the user it is executed as and must not be writable by anyone other than its owner. This makes it difficult for anyone to covertly inject and then remotely execute programs.
- `Cgistub` creates its UNIX listen socket with 0700 permissions.

---

**NOTE** Socket permissions are not respected on a number of UNIX variants, including current versions of SunOS/Solaris. To prevent a malicious user from exploiting `Cgistub`, change the server's temporary directory (using the `init.conf TempDir` directive) to a directory accessible only to the server user. For details, see the *Sun ONE Application Server Administrator's Configuration File Reference*.

---



After you have installed `cgistub`, you can create custom execution environments in the following ways:

- Specifying a Unique CGI Directory and UNIX User and Group for a Virtual Server
- Specifying a Chroot Directory for a Virtual Server

## Specifying a Unique CGI Directory and UNIX User and Group for a Virtual Server

To prevent a virtual server's CGI programs from interfering with other users, these programs should be stored in a unique directory and execute with the permissions of a unique UNIX user and group.

First, create the UNIX user and group. The exact steps required to create a user and group vary by operating system. For help, consult your operating system's documentation.

Next, follow these steps to create a `cgi-bin` directory for the virtual server:

1. Log in as the superuser.

```
su
```

2. Change to the virtual server directory.

```
cd vs_dir
```

3. Create the `cgi-bin` directory.

```
mkdir cgi-bin
```

```
chown user:group cgi-bin
```

```
chmod 755 cgi-bin
```

You can set the virtual server's CGI directory, user, and group in one of these ways:

- Use the `dir`, `user`, and `group` parameters of the `send-cgi` function in the `obj.conf` file. For more information, see the *Sun ONE Application Server Developer's Guide to NSAPI*.
- Enter this information using the Administration interface:
  - a. Open the HTTP Server component under your server instance.
  - b. Go to the Virtual Servers page.

- c. Click on the name of the virtual server for which you are specifying CGI directories.
- d. Click on the General tab.
- e. Type values in the Directory, User, and Group fields.
- f. Click on the Save button.
- g. Go to the server instance page and select the Apply Changes button.

For more information, see the *Sun ONE Application Server Administrator's Guide*.

## Specifying a Chroot Directory for a Virtual Server

To further improve security, these CGI scripts should be prevented from accessing data above and outside of the virtual server directory.

First, set up the chroot environment. The exact steps required to set up the chroot environment vary by operating system. For help, consult your operating system's documentation. The `man` pages for `ftpd` and `chroot` are often a good place to start.

These are the steps required for Solaris versions 2.6 through 8:

1. Log in as the superuser.

```
su
```

2. Change to the chroot directory. This is typically the `vs_dir` directory mentioned in the previous section.

```
cd chroot
```

3. Create `tmp` in the chroot directory:

```
mkdir tmp  
chmod 1777 tmp
```

4. Create `dev` in the chroot directory:

```
mkdir dev  
chmod 755 dev
```

5. List `/dev/tcp`, and note the major and minor numbers of the resulting output. In this example, the major number is 11 and the minor number is 42:

```
ls -lL /dev/tcp  
  
crw-rw-rw-  1 root      sys          11, 42 Apr  9 1998 /dev/tcp
```

6. Create the `tcp` device using the major and minor numbers:

```
mknod dev/tcp c 11 42
chmod 666 dev/tcp
```

7. Repeat steps 5 and 6 for each of the following devices (each device will have a different major and minor combination):

```
/dev/udp
/dev/ip
/dev/kmem
/dev/kstat
/dev/ksyms
/dev/mem
/dev/null
/dev/stderr
/dev/stdin
/dev/stdout
/dev/ticotsord
/dev/zero
```

8. Set permissions on the devices in `dev` in the `chroot` directory:

```
chmod 666 dev/*
```

9. Create and populate `lib` and `usr/lib` in the `chroot` directory:

```
mkdir usr
mkdir usr/lib
ln -s /usr/lib
ln /usr/lib/* usr/lib
```

You can ignore the messages this command generates.

If the `/usr/lib` directory is on a different file system, replace the last command with the following:

```
cp -rf /usr/lib/* usr/lib
```

10. Create and populate `bin` and `usr/bin` in the `chroot` directory:

```
mkdir usr/bin
ln -s /usr/bin
ln /usr/bin/* usr/bin
```

You can ignore the messages this command generates.

If the `/usr/bin` directory is on a different file system, replace the last command with the following:

```
cp -rf /usr/bin/* usr/bin
```

**11. Create and populate `etc` in the chroot directory:**

```
mkdir etc
```

```
ln /etc/passwd /etc/group /etc/netconfig etc
```

**12. Test the chroot environment:**

```
chroot chroot bin/ls -l
```

The output should look something like this:

```
total 14
lrwxrwxrwx  1 root  other    8 Jan 13 03:32 bin -> /usr/bin
drwxr-xr-x  2 user  group   512 Jan 13 03:42 cgi-bin
drwxr-xr-x  2 root  other   512 Jan 13 03:28 dev
drwxr-xr-x  2 user  group   512 Jan 13 03:26 docs
drwxr-xr-x  2 root  other   512 Jan 13 03:33 etc
lrwxrwxrwx  1 root  other    8 Jan 13 03:30 lib -> /usr/lib
drwxr-xr-x  4 root  other   512 Jan 13 03:32 usr
```

You can set the virtual server's chroot directory in one of these ways:

- Use the `chroot` parameter of the `send-cgi` function in the `obj.conf` file. For more information, see the *Sun ONE Application Server Developer's Guide to NSAPI*.
- Enter this information using the Administration interface:
  - a. Open the HTTP Server component under your server instance.
  - b. Go to the Virtual Servers page.
  - c. Click on the name of the virtual server for which you are specifying CGI directories.
  - d. Click on the General tab.
  - e. Type a value in the Chroot field.
  - f. Click on the Save button.
  - g. Go to the server instance page and select the Apply Changes button.

For more information, see the *Sun ONE Application Server Administrator's Guide*.

## Adding CGI Programs to the Server

To add CGI programs to the Sun ONE Application Server, simply do one of the following:

- Drop the program file in a CGI directory (if there are any).
- Give it a file name that the server recognizes as a CGI program and put it in any directory at or below the document root (if CGI file type recognition has been activated).

For UNIX, make sure the program file has execute permissions set.

## Setting the Priority of a CGI Program

To set the priority of a CGI program:

1. Open the HTTP Server component under your server instance in the Administration interface.
2. Go to the Virtual Servers page.
3. Click on the name of the virtual server for which you are specifying CGI directories.
4. Click on the General tab.
5. Type a value in the Nice field. This increment determines the CGI program's priority relative to the server. Typically, the server is run with a nice value of 0 and the nice increment would be between 0 (the CGI program runs at same priority as server) and 19 (the CGI program runs at much lower priority than server). While it is possible to increase the priority of the CGI program above that of the server by specifying a nice increment of -1, this is not recommended.
6. Click on the Save button.
7. Go to the server instance page and select the Apply Changes button.

For more information, see the *Sun ONE Application Server Administrator's Guide*.

# Windows CGI Programs

This section discusses how to install Windows CGI Programs. The following topics are included in this section:

- Overview of Windows CGI Programs
- Specifying a Windows CGI Directory
- Specifying Windows CGI as a File Type

## Overview of Windows CGI Programs

Windows CGI programs are handled much as other CGI programs. You specify a directory that contains only Windows CGI programs, or you specify that all Windows CGI programs have the same file extension, or both.

Although Windows CGI programs behave like regular CGI programs, your server processes the actual programs slightly differently. Therefore, you need to specify different directories for Windows CGI programs. If you enable the Windows CGI file type, it uses the file extension `.wCG`.

Sun ONE Application Servers support the Windows CGI 1.3a informal specification, with the following differences:

- The following keywords have been added to the `[CGI]` section to support security methods:
  - `HTTPS`: its value is on or off, depending on whether the transaction is conducted through SSL.
  - `HTTPS Keysize`: when `HTTPS` is on, this value reports the number of bits in the session key used for encryption.
  - `HTTPS Secret Keysize`: when `HTTPS` is on, this value reports the number of bits used to generate the server's private key.
- The keyword `Document Root` in the `[CGI]` section might not refer to the expected document root because the server does not have a single document root. The directory returned in this variable is the root directory for the Windows CGI program.
- The keyword `Server Admin` in the `[CGI]` section is not supported.
- The keyword `Authentication Realm` in the `[CGI]` section is not supported.
- Forms sent with multi-part/form-data encoding are not supported.

## Specifying a Windows CGI Directory

To specify directories that contain WinCGI programs (and only WinCGI programs):

1. Create the Windows CGI directory on your computer. This directory doesn't have to be a subdirectory of your document root directory. This is why you must specify a URL prefix in Step 7.
2. Open the HTTP Server component under your server instance in the Administration interface.
3. Go to the Virtual Servers page.
4. Click on the name of the virtual server for which you are specifying Windows CGI directories.
5. Click on the CGI tab.
6. Click on the WinCGI Directory option.
7. In the URL Prefix field, type the URL prefix to use for this directory. That is, the text you type appears as the directory for the CGI programs in URLs.

For example, if you type `cgi-bin` as the URL prefix, then all URLs to these CGI programs have the following structure:

```
http://yourserver.domain.com/cgi-bin/program-name
```

---

**NOTE** The URL prefix you specify can be different from the real CGI directory you specify in the previous step.

---

8. In the WINCGI Directory text field, type the location of the directory as an absolute path.
9. To enable script tracing, select the Yes radio button.
10. Click on the OK button.
11. Go to the server instance page and select the Apply Changes button.

To remove an existing Windows CGI directory, click that directory's Remove button in the WINCGI Directory page. To change the URL prefix or Windows CGI directory of an existing directory, click that directory's Edit button.

Copy your Windows CGI programs into the directories you've specified. Remember that any file in those directories is processed as a Windows CGI file.

## Specifying Windows CGI as a File Type

To specify a file extension for Windows CGI files, perform the following steps:

1. Open the HTTP Server component under your server instance in the Administration interface.
2. Go to the Virtual Servers page.
3. Click on the name of the virtual server for which you are specifying a Windows CGI file type.
4. Note the name of the MIME Types File for the virtual server.
5. Go to the MIME Type Files page.
6. Click on the name that matches the name you noted in Step 4.
7. Click on the MIME File... button.
8. Add a new MIME type with the following settings:
  - o Category: `type`
  - o Content-Type: `magnus-internal/wincgi`
  - o File Suffix: Enter the file suffixes that you want the server to associate with Windows CGI. If you activated CGI, WinCGI, and shell CGI file types, you must specify a different suffix for each type of CGI. For example, you can't use the suffix `.exe` for both a CGI program and a shell CGI program. If you need to, you can edit the other MIME type fields on the page so that the suffixes are unique.
9. Click on the New Type button.
10. Go to the server instance page and select the Apply Changes button.

## Shell CGI Programs for Windows

This section discusses how to install Shell CGI Programs for Windows. The following topics are included in this section:

- Overview of Shell CGI Programs for Windows
- Specifying a Shell CGI Directory (Windows)
- Specifying Shell CGI as a File Type (Windows)



## Overview of Shell CGI Programs for Windows

Shell CGI is a server configuration that lets you run CGI applications using the file associations set in Windows.

For example, if the server gets a request for a shell CGI file called `hello.pl`, the server uses the Windows file associations to run the file using the program associated with the `.pl` extension. If the `.pl` extension is associated with the program `C:\bin\perl.exe`, the server attempts to execute the `hello.pl` file as follows:

```
c:\bin\perl.exe hello.pl
```

The easiest way to configure shell CGI is to create a directory in your server's document root that contains only shell CGI files. However, you can also configure the server to associate specific file extensions with shell CGI by editing MIME types from the Sun ONE Application Server.

---

**NOTE** For information on setting Windows file extensions, see your Windows documentation.

---

## Specifying a Shell CGI Directory (Windows)

To specify directories that contain shell CGI programs (and only shell CGI programs):

1. Create the shell CGI directory on your computer. This directory doesn't have to be a subdirectory of your document root directory. This is why you must specify a URL prefix in Step 7.
2. Open the HTTP Server component under your server instance in the Administration interface.
3. Go to the Virtual Servers page.
4. Click on the name of the virtual server for which you are specifying shell CGI directories.
5. Click on the CGI tab.
6. Click on the Shell CGI Directory option.

7. In the URL Prefix field, type the URL prefix to use for this directory. That is, the text you type appears as the directory for the CGI programs in URLs.

For example, if you type `cgi-bin` as the URL prefix, then all URLs to these CGI programs have the following structure:

```
http://yourserver.domain.com/cgi-bin/program-name
```

---

**NOTE** The URL prefix you specify can be different from the real CGI directory you specify in the previous step.

---

8. In the Shell CGI Directory text field, type the location of the directory as an absolute path.
9. Click on the OK button.
10. Go to the server instance page and select the Apply Changes button.
11. Make sure that any files in the shell CGI directory also have file associations set in Windows. The server returns an error if it attempts to run a file that has no file-extension association.

---

**CAUTION** The server must have read and execute permissions to the shell CGI directory. For Windows, the user account the server runs as (for example, `LocalSystem`) must have rights to read and execute programs in the shell CGI directory.

---

To remove an existing shell CGI directory, click that directory's Remove button in the Shell CGI Directory page. To change the URL prefix or shell CGI directory of an existing directory, click that directory's Edit button.

Copy your shell CGI programs into the directories you've specified. Remember that any file in those directories is processed as a shell CGI file.

## Specifying Shell CGI as a File Type (Windows)

You can use the Sun ONE Application Server's `mime.types` file to associate a file extension with the shell CGI feature. This is different from creating an association in Windows.

To associate a file extension with the shell CGI feature in the server, for example, you can create an association for files with the `.pl` extension. When the server gets a request for a file with that extension, the server knows to treat the file as a shell CGI file by calling the executable associated in Windows with that file extension.

To associate a file extension as a shell CGI file, perform the following steps:

1. Open the HTTP Server component under your server instance in the Administration interface.
2. Go to the Virtual Servers page.
3. Click on the name of the virtual server for which you are specifying a Windows CGI file type.
4. Note the name of the MIME Types File for the virtual server.
5. Go to the MIME Type Files page.
6. Click on the name that matches the name you noted in Step 4.
7. Click on the MIME File... button.
8. Add a new MIME type with the following settings:
  - o **Category:** `type`
  - o **Content-Type:** `magnus-internal/shellcgi`
  - o **File Suffix:** Enter the file suffixes that you want the server to associate with Windows CGI. If you activated CGI, WinCGI, and shell CGI file types, you must specify a different suffix for each type of CGI. For example, you can't use the suffix `.exe` for both a CGI program and a shell CGI program. If you need to, you can edit the other MIME type fields on the page so that the suffixes are unique.
9. Click on the New Type button.
10. Go to the server instance page and select the Apply Changes button.

# The Query Handler

---

**NOTE** The use of Query Handlers is outdated. Although Sun ONE Application Server and Netscape Navigator clients still support it, it is rarely used. It is much more common for people to use forms in their HTML pages to submit queries.

---

You can specify a default query handler CGI program. A query handler processes text sent to it via the ISINDEX tag in an HTML file.

ISINDEX is similar to a form text field in that it creates a text field in the HTML page that can accept typed input. Unlike the information in a form text field, however, the information in the ISINDEX box is immediately submitted when the user presses Return. When you specify your default query handler, you tell your server to which program to direct the input. For an in-depth discussion of the ISINDEX tag, see an HTML reference manual.

To set a query handler, perform the following steps:

1. Open the HTTP Server component under your server instance in the Administration interface.
2. Go to the Virtual Servers page.
3. Click on the name of the virtual server for which you are specifying a query handler.
4. Click on the CGI tab.
5. Click on the Query Handler option.
6. Use the Editing Picker to select the resource you want to set with a default query handler.

If you choose a directory, the query handler you specify runs only when the server receives a URL for that directory or any file in that directory.

7. In the Default Query Handler field, enter the full path for the CGI program you want to use as the default for the resource you chose.
8. Click on the OK button.
9. Go to the server instance page and select the Apply Changes button.

# Perl CGI Programs

You cannot run CGIs using Perl 5.6.x with the `-w` flag. Instead, include the following code in the file:

```
use warnings;
```

## Global CGI Settings

To change global CGI settings:

1. Open the HTTP Server component under your server instance in the Administration interface.
2. Go to the HTTP Server page.
3. Click on the Advanced tab.
4. Click on the CGI option.
5. You can change the following settings:
  - `MinCGIStubs` - Sets the number of CGIStub processes that are started by default. This value must be lower than `MaxCGIStubs`. The default is 2.
  - `CGIExpirationTimeout` - Specifies the maximum time in seconds that CGI processes are allowed to run before being killed. The default is 0, which means processes are allowed to run indefinitely.
  - `CGIStubIdleTimeout` - Kills any CGIStub processes that have been idle for this number of seconds. The default is 30.
  - `MaxCGIStubs` - Sets the maximum number of CGIStub processes the server can execute concurrently. The default is 10.
6. Click on the OK button.
7. Go to the server instance page and select the Apply Changes button.

For more information about these global CGI settings, see the description of the `init.conf` file in the *Sun ONE Application Server Administrator's Configuration File Reference*.

# CGI Variables

In addition to the standard CGI variables, you can use the Sun ONE Application Server CGI variables in CGI programs to access information about the client certificate if the server is running in secure mode. The `CLIENT_CERT` and `REVOCACTION` variables are available only when client certificate based authentication is enabled.

The following table lists the Sun ONE Application Server CGI variables. The left column lists the variables, and the right column lists descriptions of those variables.

CGI Variables	
Variable	Description
<code>SERVER_URL</code>	The URL of the server that the client requested
<code>HTTP_xxx</code>	An incoming HTTP request header, where <code>xxx</code> is the name of the header
<code>HTTPS</code>	ON if the server is in secure mode and OFF otherwise
<code>HTTPS_KEYSIZE</code>	The keysize of the SSL handshake (available if the server is in secure mode)
<code>HTTPS_SECRETKEYSIZE</code>	The keysize of the secret part of the SSL handshake (available if the server is in secure mode)
<code>HTTPS_SESSIONID</code>	The session ID for the connection (available if the server is in secure mode)
<code>CLIENT_CERT</code>	The certificate that the client provided (binary DER format)
<code>CLIENT_CERT_SUBJECT_DN</code>	The Distinguished Name of the subject of the client certificate
<code>CLIENT_CERT_SUBJECT_OU</code>	The Organization Unit of the subject of the client certificate
<code>CLIENT_CERT_SUBJECT_O</code>	The Organization of the subject of the client certificate
<code>CLIENT_CERT_SUBJECT_C</code>	The Country of the subject of the client certificate
<code>CLIENT_CERT_SUBJECT_L</code>	The Location of the subject of the client certificate
<code>CLIENT_CERT_SUBJECT_ST</code>	The State of the subject of the client certificate
<code>CLIENT_CERT_SUBJECT_E</code>	The E-mail of the subject of the client certificate

## CGI Variables

<b>Variable</b>	<b>Description</b>
CLIENT_CERT_SUBJECT_UID	The UID part of the CN of the subject of the client certificate
CLIENT_CERT_ISSUER_DN	The Distinguished Name of the issuer of the client certificate
CLIENT_CERT_ISSUER_OU	The Organization Unit of the issuer of the client certificate
CLIENT_CERT_ISSUER_O	The Organization of the issuer of the client certificate
CLIENT_CERT_ISSUER_C	The Country of the issuer of the client certificate
CLIENT_CERT_ISSUER_L	The Location of the issuer of the client certificate
CLIENT_CERT_ISSUER_ST	The State of the issuer of the client certificate
CLIENT_CERT_ISSUER_E	The E-mail of the issuer of the client certificate
CLIENT_CERT_ISSUER_UID	The UID part of the CN of the issuer of the client certificate
CLIENT_CERT_VALIDITY_START	The start date of the certificate
CLIENT_CERT_VALIDITY_EXPIRES	The expiration date of the certificate
CLIENT_CERT_EXTENSION_XXX	The certificate extension, where xxx is the name of the extension
REVOCAATION_METHOD	The name of the certificate revocation method if it exists
REVOCAATION_STATUS	The status of certificate revocation if it exists





# Index

## A

- abbrev, value of sizefmt attribute 134
- Administration interface
  - changing servlet output 44
  - configuring a default web module 25
  - configuring the web container 27
  - deployment using 87
  - enabling SHTML 132
  - global CGI settings 157
  - setting a query handler 156
  - setting CGI program priority 149
  - setting the default locale 23
  - setting the virtual server's CGI directory 145
  - setting the virtual server's chroot directory 148
  - setting up dynamic reloading 88
  - specifying a shell CGI directory 153
  - specifying CGI directories 140
    - Windows 151
  - specifying CGI file extensions 142
    - Windows 152
- agent attribute 123
- API reference
  - CGI 139
  - JavaBeans 20
  - JSP 20, 55
  - servlets 19
- appserv-tags.jar file 56
- appserv-tags.tld file 56
- asadmin deploy command 59, 87
- attributes, about 91
- authentication 75
  - form-based login 77

- HTTP basic 76
  - single sign-on 77
  - SSL mutual 76
- authorization 79
  - constraints 80
  - roles 79

## B

- BaseCache cacheClassName value 110
- basic authentication 76
- beans in JSPs 20
- bin directory for CGI 147
- BoundedMultiLruCache cacheClassName value 110
- bytes, value of sizefmt attribute 134

## C

- cache 45, 108
  - default configuration 47
  - example configuration 47
  - for JSPs 66
  - for static file content 46
  - helper class 46, 50
- cache element 108
- cache tag 56
- cacheClassName property 110
- cache-helper element 111

- CacheHelper interface 48, 50, 111
- cache-helper-ref element 114
- cacheKeyGeneratorAttrName property 50, 112
- cache-mapping element 112
- cache-on-match attribute 117, 118
- cache-on-match-failure attribute 117, 118
- certificate
  - CGI variables 158
  - fetching 80
- CGI 139
  - adding programs to the server 149
  - and HTTPS 150
  - and J2EE applications 140
  - and virtual servers 145
  - client certificate variables 158
  - custom execution environment 143
  - enabling 140
  - global settings 157
  - Perl programs 157
  - security for 81
  - setting a program's priority 149
  - shell programs for Windows
    - installing 152
    - specifying file extensions 155
  - specifying CGI directories 140
  - specifying file extensions 142, 152
  - variables 158
  - website 139
  - Windows 150
    - directories for 151
    - programs, overview 150
    - specifying file extensions 152
- cgi attribute of exec command 136
- cgi-bin directory 145
- CGIExpirationTimeout CGI setting 157
- Cgistub 143
- CGIStubIdleTimeout CGI setting 157
- charset attribute 123
- chroot directory 146
- classdebuginfo attribute 120
- classes directory 84
- classloader delegation model 119
- class-loader element 118
- class-name attribute 111

- client certificate
  - CGI variables 158
  - fetching 80
- CloudScape 27
- cmd attribute of exec command 135
- compiling JSPs 59
- config SHTML command 134
- connection pooling, database 27
- constraint-field element 116
- contentType attribute of page directive 24
- cookieComment property 103
- cookieDomain property 103
- cookieMaxAgeSeconds property 103
- cookieName property 103
- cookiePath property 103
- cookie-properties element 102
- cookies 64
- crossContextAllowed property 93
- custom execution environment 143

## D

- database connection pooling 27
- DATE\_GMT SHTML variable 136
- DATE\_LOCAL SHTML variable 136
- debugging 22
- default virtual server 25
- default web module 26, 42
- default-helper element 111
- default-locale attribute 122
- default-resource-principal element 106
- delegate attribute 119
- deployment 83
  - approaches 86
  - descriptors 85
  - dynamic 86
  - dynamic reloading 88
- description element 95
- destroy method 34, 51
- destroying servlets 51
- directory property 73, 101

- DOCUMENT\_NAME SHTML variable 136
- DOCUMENT\_URI SHTML variable 136
- doGet method 32, 34, 52
- doPost method 32, 34, 52
- dynamic
  - deployment 86
  - reloading 88
  - of JSPs 59, 89

## E

- echo SHTML command 135
- EJB components, accessing 37
- ejb-ref element 107
- ejb-ref-name element 107
- enableCookies property 102
- enabled attribute 109
- enableURLRewriting property 102
- encoding
  - hidden field for 123
  - of JSPs 24, 120
  - of servlets 23
- environment variables, SHTML 136
- errmsg attribute of config command 134
- exceptions 55
- exec SHTML command 135
- execution environment 143
- extensions, for CGI 142, 152
- extra-class-path attribute 118

## F

- field, hidden, for character encoding 123
- file attribute of include command 134
- file extensions, for CGI 142, 152
- flastmod SHTML command 135
  - affected by timefmt attribute 134
- flush tag 58
- formats, time 137

- form-based login 77
- form-hint-field attribute 124
- Forte for Java 14
- forward method 41, 43
- fsize SHTML command 135

## G

- generic servlets 31
- getAttribute method 68
- getAttributeNames method 68
- getCreationTime method 66
- getId method 66
- getLastAccessedTime method 66
- getMethod method 35, 52
- getParameter method 123
- getRemoteUser method 67
- getRequestedSessionId method 67
- getSession method 65
- group-name element 97
- groups in realms 95

## H

- Handler, Query 156
- handling requests 51
- hidden field, for character encoding 123
- HTML tags, server-parsed commands *see* SHTML
- HTTP basic authentication 76
- HTTP servlets 32
- http-method element 115
- HTTPS, and CGI 150
- HttpServletRequest 47, 65
- HttpSession 66
- HttpSession interface 63
- HttpSessionBindingListener interface 68

## I

- idLengthBytes property 102
- ieClassId property 120
- include method 41
- include SHTML command 134
- init method 33, 51
- init.conf file, and CGI 144, 157
- init-cgi function 144
- instantiating servlets 51
- internationalization 22, 121
- invalidate method 68
- ISINDEX tag 156
- isNew method 66
- isRequestedSessionIdFromCookie method 67
- isRequestedSessionIdFromURL method 67
- isRequestedSessionIdValid method 67

## J

- Java Database Connectivity *see* JDBC
- Java Message Service *see* JMS
- Java Naming Directory Interface *see* JNDI
- Java Servlet API 19
- JavaBeans 20
- javaCompilerPath property 120
- javaCompilerPlugin property 120
- javaEncoding attribute 120
- JDBC driver 27
- jikes compiler 120
- JMS 106
- JNDI 38, 39
- jndi-name element 107
- JSP 1.2 specification 20, 55
- jspc command 59
- jsp-config element 119
- JSPs
  - about 20, 53
  - accessing Java functionality 20
  - API reference 20, 55
  - beans in 20

- caching 56
- character encoding 24
- command-line compiler 59
- compiler for 120
- configuring 119
- creating 54
- debugging 62
- dynamic reloading of 59, 89, 121
- encoding of 120
- exceptions 55
- generated source code 86
- invoking from servlets 41
- portability 55
- precompiling 59
- syntax 54
- tag libraries 55

## K

- keepgenerated property 120
- key attribute
  - of cache tag 57
  - of flush tag 58
- key-field element 116

## L

- largefile property 120
- LAST\_MODIFIED SHTML variable 136
- lib directory
  - for a web application 84
  - for CGI 147
  - for the entire server 89, 133
  - and JSP tags 56
- locale attribute
  - server.xml file 23
  - sun-web.xml file 122
- locale-charset-info element 121
- locale-charset-map element 122
- logging in the web container 27
- login, form-based 77

LruCache cacheClassName value 110

## M

manager-properties element 99  
mappedfile property 121  
match-expr attribute 118  
MaxCGIStubs CGI setting 157  
max-entries attribute 109  
maxSessions property 71, 72, 100  
MaxSize property 110  
mime.types file, CGI extensions in 142, 155  
MinCGIStubs CGI setting 157  
MultiLruCache cacheClassName value 110  
MultiLRUsegmentSize property 110  
mutual authentication 76

## N

name attribute 94, 111, 114, 115, 116, 117  
name element 106  
nocache attribute of cache tag 57  
nscf.conf file 46

## O

obj.conf file  
    and CGI 141, 142, 143, 145, 148  
    and SHTML 133  
Oracle 27  
output from servlets 44

## P

page directive 24  
parameter-encoding element 123

parameters, servlet, accessing 36  
parse-html function 133  
password element 106  
Perl 157  
persistence-type attribute 99  
persistent session manger 71  
PersistentManager 71  
plugin tag 120  
Pointbase 27  
pooling  
    of database connections 27  
    of servlets 52  
portability 55  
precompiling JSPs 59  
principal-name element 97  
private directory 144  
programmatic login 76  
properties, about 94  
property element 94

## Q

Query Handler 156  
QUERY\_STRING\_UNESCAPED SHTML variable  
136

## R

realms  
    mapping groups and users to 95  
    use in form-based login 77  
reapIntervalSeconds property 70, 72, 100, 101  
refresh attribute of cache tag 57  
refresh-field element 115  
.reload file 89  
reloading, dynamic 88  
    of JSPs 59, 89  
reload-interval property 121  
removeAttribute method 68

- removing servlets 51
- request object 51
- requirement rules 90
- resource allocation 52
- resource-env-ref element 104
- resource-env-ref-name element 104
- resource-ref element 105
- response pages 40
- res-ref-name element 105
- role-name element 96
- roles 79

## S

- scope attribute 115, 116, 117
- scratchdir property 121
- Secure Socket Layer *see* SSL
- security 75
  - and servlets 36
  - of sessions 64
- security-role-mapping element 95
- send-cgi function 143, 145, 148
- server.xml file
  - and JNDI names 107
  - changing servlet output 45
  - configuring a default web module 25
  - configuring single sign-on 78
  - configuring the web container 27
  - setting the default locale 23
  - setting up dynamic reloading 88
  - variables in 143
- server-parsed HTML *see* SHTML
- service method 32, 34, 52
- Servlet 2.3 specification 19
- servlet element 96
- <SERVLET> tag 136
- servlet-name element 96
- servlets
  - about 19, 29
  - accessing EJB components 37
  - accessing parameters 36
  - API reference 19
  - caching 45
  - character encoding 23
  - creating 32
  - destroying 51
  - embedding in HTML files 136
  - engine 51, 52
  - execution cycle 30
  - generic vs. HTTP 31
  - instantiating 51
  - invoking
    - from another servlet 43
    - using a URL 42
  - invoking JSPs from 41
  - output 44
  - pooling 52
  - removing 51
  - request handling 51
  - response pages 40
  - security 36
  - sessions 36
  - specification 19
  - thread safety 39
  - user authentication 75
  - user authorization 79
- session managers 97
  - default 70
  - persistent 71
  - PersistentManager 71
  - StandardManager 70
- session-config element 98
- sessionFilename property 71, 100
- session-manager element 98
- session-properties element 101
- sessions
  - about 63
  - cookies 64
  - invalidating 68
  - properties 66
  - security 36, 64
  - servlets 36
  - session managers 69
  - URL rewriting 64
- session-timeout element 102
- setAttribute method 37, 68
- setCharacterEncoding method 23
- setContentType method 23, 24

- setLocale method 24
- shell programs for Windows CGI 152
- SHTML 131
  - and J2EE applications 131
  - commands and syntax 133
  - embedding servlets in 136
  - enabling 132
  - environment variables 136
  - security for 81
- single sign-on 77
- singleThreadedServletPoolSize property 40, 52, 93
- SingleThreadModel class 40
- sizefmt attribute of config command 134
- SSI 136
- SSL
  - and CGI 150, 158
  - mutual authentication 76
- StandardManager 70
- store-properties element 100
- subelements, about 90
- Sun customer support 16
- Sun ONE Message Queue 106
- Sun ONE Studio
  - creating web applications using 22
  - debugging JSPs using 62
  - deployment using 88
  - renamed from Forte for Java 14
- sun-appserv-jspc Ant task 59
- sun-web.xml file
  - elements in 91
  - example of 130
  - schema for 89
- sun-web-app element 92
- sun-web-app\_2\_3-0.dtd file 89
- syntax of JSPs 54

## T

- tag libraries 55
- tags
  - for JSP caching 56
  - SHTML 131

- summary of 55
- tempdir context attribute 73
- tempdir property 93
- thread safety 39
- time formats 137
- timefmt attribute of config command 134
- timeout attribute of cache tag 57
- timeout element 114
- timeout-in-seconds attribute 109
- timeoutSeconds property 102

## U

- URL rewriting 64
- url-pattern element 114
- users in realms 95

## V

- value attribute 94
- value element 117
- variables
  - CGI 158
  - for send-cgi function 143
  - SHTML 136
- virtual attribute of include command 134
- virtual servers 24
  - and CGI 145
  - default 25

## W

- WAR file 17, 84
  - creating 87
- .wgc files 150
- web applications 17
  - creating 21
  - debugging 22

- deploying 83
- directory structure 84
- examples 27
- web container, configuring 27
- web module, default 26, 42
- web service 119
- web.xml file
  - and the sun-web.xml file 85
  - example of 124
  - location 84
  - session-timeout element 102
- WEB-INF directory 84
- Windows CGI *see* CGI