



System Management Services (SMS) 1.4 Administrator Guide

Sun Microsystems, Inc.
4150 Network Circle
Santa Clara, CA 95054 U.S.A.
650-960-1300

Part No. 817-3056-10
November 2003, Revision A

Submit comments about this document at: <http://www.sun.com/hwdocs/feedback>

Copyright 2003 Sun Microsystems, Inc., 4150 Network Circle, Santa Clara, California 95054, U.S.A. All rights reserved.

Sun Microsystems, Inc. has intellectual property rights relating to technology embodied in the product that is described in this document. In particular, and without limitation, these intellectual property rights may include one or more of the U.S. patents listed at <http://www.sun.com/patents>, and one or more additional patents or pending patent applications in the U.S. and in other countries.

This document and the product to which it pertains are distributed under licenses restricting their use, copying, distribution, and decompilation. No part of the product or of this document may be reproduced in any form by any means without prior written authorization of Sun and its licensors, if any.

Third-party software, including font technology, is copyrighted and licensed from Sun suppliers.

Parts of the product may be derived from Berkeley BSD systems, licensed from the University of California. UNIX is a registered trademark in the U.S. and other countries, exclusively licensed through X/Open Company, Ltd.

Sun, Sun Microsystems, the Sun logo, AnswerBook2, docs.sun.com, Sun Fire, OpenBoot PROM, Sun Remote Services Net Connect, and Solaris are trademarks, registered trademarks, or service marks of Sun Microsystems, Inc. in the U.S. and other countries.

All SPARC trademarks are used under license and are trademarks or registered trademarks of SPARC International, Inc. in the U.S. and other countries. Products bearing SPARC trademarks are based upon an architecture developed by Sun Microsystems, Inc.

The OPEN LOOK and Sun™ Graphical User Interface was developed by Sun Microsystems, Inc. for its users and licensees. Sun acknowledges the pioneering efforts of Xerox in researching and developing the concept of visual or graphical user interfaces for the computer industry. Sun holds a non-exclusive license from Xerox to the Xerox Graphical User Interface, which license also covers Sun's licensees who implement OPEN LOOK GUIs and otherwise comply with Sun's written license agreements.

U.S. Government Rights—Commercial use. Government users are subject to the Sun Microsystems, Inc. standard license agreement and applicable provisions of the FAR and its supplements.

DOCUMENTATION IS PROVIDED "AS IS" AND ALL EXPRESS OR IMPLIED CONDITIONS, REPRESENTATIONS AND WARRANTIES, INCLUDING ANY IMPLIED WARRANTY OF MERCHANTABILITY, FITNESS FOR A PARTICULAR PURPOSE OR NON-INFRINGEMENT, ARE DISCLAIMED, EXCEPT TO THE EXTENT THAT SUCH DISCLAIMERS ARE HELD TO BE LEGALLY INVALID.

Copyright 2003 Sun Microsystems, Inc., 4150 Network Circle, Santa Clara, California 95054, Etats-Unis. Tous droits réservés.

Sun Microsystems, Inc. a les droits de propriété intellectuels relatants à la technologie incorporée dans le produit qui est décrit dans ce document. En particulier, et sans la limitation, ces droits de propriété intellectuels peuvent inclure un ou plus des brevets américains énumérés à <http://www.sun.com/patents> et un ou les brevets plus supplémentaires ou les applications de brevet en attente dans les Etats-Unis et dans les autres pays.

Ce produit ou document est protégé par un copyright et distribué avec des licences qui en restreignent l'utilisation, la copie, la distribution, et la décompilation. Aucune partie de ce produit ou document ne peut être reproduite sous aucune forme, par quelque moyen que ce soit, sans l'autorisation préalable et écrite de Sun et de ses bailleurs de licence, s'il y en a.

Le logiciel détenu par des tiers, et qui comprend la technologie relative aux polices de caractères, est protégé par un copyright et licencié par des fournisseurs de Sun.

Des parties de ce produit pourront être dérivées des systèmes Berkeley BSD licenciés par l'Université de Californie. UNIX est une marque déposée aux Etats-Unis et dans d'autres pays et licenciée exclusivement par X/Open Company, Ltd.

Sun, Sun Microsystems, le logo Sun, AnswerBook2, docs.sun.com, Sun Fire, OpenBoot PROM, Sun Remote Services Net Connect, et Solaris sont des marques de fabrique ou des marques déposées de Sun Microsystems, Inc. aux Etats-Unis et dans d'autres pays.

Toutes les marques SPARC sont utilisées sous licence et sont des marques de fabrique ou des marques déposées de SPARC International, Inc. aux Etats-Unis et dans d'autres pays. Les produits portant les marques SPARC sont basés sur une architecture développée par Sun Microsystems, Inc.

L'interface d'utilisation graphique OPEN LOOK et Sun™ a été développée par Sun Microsystems, Inc. pour ses utilisateurs et licenciés. Sun reconnaît les efforts de pionniers de Xerox pour la recherche et le développement du concept des interfaces d'utilisation visuelle ou graphique pour l'industrie de l'informatique. Sun détient une licence non exclusive de Xerox sur l'interface d'utilisation graphique Xerox, cette licence couvrant également les licenciés de Sun qui mettent en place l'interface d'utilisation graphique OPEN LOOK et qui en outre se conforment aux licences écrites de Sun.

LA DOCUMENTATION EST FOURNIE "EN L'ÉTAT" ET TOUTES AUTRES CONDITIONS, DECLARATIONS ET GARANTIES EXPRESSES OU TACITES SONT FORMELLEMENT EXCLUES, DANS LA MESURE AUTORISEE PAR LA LOI APPLICABLE, Y COMPRIS NOTAMMENT TOUTE GARANTIE IMPLICITE RELATIVE A LA QUALITE MARCHANDE, A L'APTITUDE A UNE UTILISATION PARTICULIERE OU A L'ABSENCE DE CONTREFAÇON.



Adobe PostScript

Contents

Preface	xix
1. Introduction to System Management Services	1
Sun Fire High-End Systems	1
Redundant SCs	2
SMS Features	3
System Architecture	5
SMS Administration Environment	6
Network Connections for Administrators	6
SMS Operating Environment	7
▼ To Begin Using the SC	7
SMS Console Window	8
▼ To Display a Console Window Locally	8
Tilde Usage	10
Remote Console Session	11
Sun Management Center	11
2. SMS Security Options and Administrative Privileges	13
Security Options	14
Administration Privileges	15

Platform Administrator Group	16
Platform Operator Group	18
Platform Service Group	18
Domain Administrator Group	20
Domain Configuration Group	22
Superuser Privileges	23
All Privileges	23

3. SMS Internals 29

Startup Flow	29
SMS Daemons	30
Capacity on Demand Daemon	34
Domain Configuration Agent	35
Domain Status Monitoring Daemon	36
Domain X Server	37
Error and Fault Handling Daemon	38
Event Log Access Daemon	39
Event Reporting Daemon	40
Environmental Status Monitoring Daemon	40
Failover Management Daemon	41
FRU Access Daemon	42
Hardware Access Daemon	43
Key Management Daemon	45
Management Network Daemon	48
Message Logging Daemon	49
OpenBoot PROM Support Daemon	50
Platform Configuration Database Daemon	51
Platform Configuration	52
Domain Configuration	53

System Board Configuration	54
SMS Startup Daemon	54
Scripts	55
Spare Mode	57
Main Mode	57
Domain-Specific Process Startup	58
Monitoring and Restarts	58
SMS Shutdown	58
Task Management Daemon	58
Environment Variables	59
4. SMS Configuration	61
Domain Configuration Units	62
Domain Configuration Requirements	62
DCU Assignment	63
Static Versus Dynamic Domain Configuration	63
Global Automatic Dynamic Reconfiguration	64
Configuration for Platform Administrators	64
Available Component List	65
▼ To Set Up the Available Component List	65
Configuring Domains	67
▼ To Name or Change Domain Names From the Command Line	67
▼ To Add Boards to a Domain From the Command Line	67
▼ To Delete Boards From a Domain From the Command Line	70
▼ To Move Boards Between Domains From the Command Line	71
▼ To Set Domain Defaults	72
▼ To Obtain Board Status	73
▼ To Obtain Domain Status	74
Virtual Time of Day	76

Setting the Date and Time 76

- ▼ To Set the Date on the SC 77
- ▼ To Set the Date for Domain eng2 77
- ▼ To Display the Date on the SC 77
- ▼ To Display the Date on Domain eng2 77

Configuring NTP 78

- ▼ To Create the `ntp.conf` File 78

Virtual ID PROM 81

- Flashupdate Command 81

Configuration for Domain Administrators 82

Configuring Domains 82

- ▼ To Add Boards to a Domain From the Command Line 82
- ▼ To Delete Boards From a Domain From the Command Line 84
- ▼ To Move Boards Between Domains From the Command Line 86
- ▼ To Set Domain Defaults 88
- ▼ To Obtain Board Status 89
- ▼ To Obtain Domain Status 89
- ▼ To Obtain Device Status 90

Virtual Keyswitch 91

Setkeyswitch 91

- ▼ To Set the Virtual Keyswitch On in Domain A 94
- ▼ To Display the Virtual Keyswitch Setting in Domain A 94

Virtual NVRAM 94

Setting the OpenBoot PROM Variables 95

- ▼ To Recover From a Repeated Domain Panic 97
- ▼ To Set the OpenBoot PROM Security Mode Variable in Domain A 98
- ▼ To See the OpenBoot PROM Variables 98

Degraded Configuration Preferences 99

Setbus	99
▼ To Set All Buses on All Active Domains to Use Both CSBs	99
Showbus	100
▼ To Show All Buses on All Active Domains	100
5. Automatic Diagnosis and Recovery	101
Automatic Diagnosis and Recovery Overview	101
Hardware Errors Associated with Domain Stops	102
Non-Fatal Domain Hardware Errors	104
POST-Detected Hardware Failures	106
Enabling Email Event Notification	107
▼ To Enable Email Event Notification	108
Configuring an Email Template	109
Configuring the Email Control File	111
Testing Email Event Notification	114
▼ To Test Email Event Notification	115
What To Do If Test Email Fails	116
Obtaining Diagnosis and Recovery Information	117
Reviewing Diagnosis Events	117
Reviewing the Event Log	118
6. Capacity on Demand	121
COD Overview	121
COD Licensing Process	122
COD RTU License Allocation	122
Instant Access CPUs	123
Instant Access CPUs as Hotspares	124
Resource Monitoring	124
Getting Started with COD	124

Managing COD RTU Licenses	125
▼ To Obtain and Add a COD RTU License Key to the COD License Database	125
▼ To Delete a COD License Key From the COD License Database	126
▼ To Review COD License Information	127
Activating COD Resources	128
▼ To Enable Instant Access CPUs and Reserve Domain RTU Licenses	130
Monitoring COD Resources	132
COD CPU/Memory Boards	132
▼ To Identify COD CPU/Memory Boards	132
COD Resource Usage	133
▼ To View COD Usage By Resource	133
▼ To View COD Usage by Domain	134
▼ To View COD Usage by Resource and Domain	137
Deconfigured and Unlicensed COD CPUs	139
Other COD Information	139

7. Domain Control 141

Domain Boot	141
Keyswitch On	142
Power	142
▼ To Power System Boards On and Off From the Command Line	143
▼ To Recover From Power Failure	144
Domain-Requested	145
Automatic System Recovery (ASR)	145
Fast Boot	145
Domain Abort/Reset	146
Hardware Control	147
Power-On Self-Test (POST)	147

Blacklist Editing	148
Platform and Domain Blacklisting	148
▼ To Blacklist a Component	149
▼ To Remove a Component From the Blacklist	150
ASR Blacklist	152
Power Control	153
Fan Control	154
Hot-Swap	154
Hot-Unplug	155
Hot-Plug	155
SC Reset and Reboot	155
▼ To Reset the Main or Spare SC	155
HPU LEDs	156
8. Domain Services	159
Management Network Overview	159
I1 Network	160
I2 Network	162
External Network Monitoring	163
MAN Daemons and Drivers	164
Management Network Services	165
Domain Console	165
Message Logging	166
Dynamic Reconfiguration	167
Network Boot and Solaris Software Installation	167
SC Heartbeats	168
9. Domain Status	169
Software Status	169

Status Commands	170
showboards Command	170
showdevices Command	170
showenvironment Command	170
showobpparams Command	171
showplatform Command	171
showxirstate Command	173
Solaris Software Heartbeat	173
Hardware Status	174
Hardware Configuration	174
Environmental Status	175
▼ To Display the Environment Status for Domain A	175
Hardware Error Status	175
SC Hardware and Software Status	176
10. SC Failover	179
Overview	179
Fault Monitoring	181
File Propagation	181
Failover Management	183
Startup	183
Main SC	183
Spare SC	183
Failover CLIs	184
setfailover Command	184
showfailover Command	185
Command Synchronization	187
cmdsnc CLIs	188
initcmdsnc Command	188

savecmdsync Command	188
cancelcmdsync Command	189
runcmdsync Command	189
showcmdsync Command	189
Data Synchronization	189
setdatasync Command	190
showdatasync Command	190
Failure and Recovery	191
Failover on Main SC (Main Controlled Failover)	192
Fault on Main SC (Spare Takes Over Main Role)	194
I2 Network Fault	195
Fault on Main SC (I2 Network Is Also Down)	195
Fault Recovery and Reboot	195
I2 Fault Recovery	195
Reboot and Recovery	196
Client Failover Recovery	197
Security	198
11. Domain Events	199
Message Logging	199
Log File Maintenance	200
Log File Management	204
Domain Reboot Events	205
Domain Reboot Initiation	205
Domain Boot Failure	205
Domain Panic Events	206
Domain Panic	207
Domain Panic Hang	207
Repeated Domain Panic	208

Solaris Software Hang Events	208
Hardware Configuration Events	209
Hot-Plug Events	209
Hot-Unplug Events	209
POST-Initiated Configuration Events	210
Environmental Events	210
Over-Temperature Events	212
Power Failure Events	212
Out-of-Range Voltage Events	212
Under-Power Events	212
Fan Failure Events	212
Clock Failure Events	213
Hardware Error Events	213
Domain Stop Events	214
CPU-Detected Events	215
Record Stop Events	215
Other ASIC Failure Events	215
SC Failure Events	215
12. SMS Utilities	217
SMS Backup Utility	217
SMS Restore Utility	218
SMS Version Utility	219
Version Switching	220
▼ To Switch Between Two Adjacent, Co-resident Installations of SMS	220
SMS Configuration Utility	221
UNIX Groups	221
Access Control List (ACL)	221

Network Configuration 222

MAN Configuration 223

A. SMS man Pages 225

B. Error Messages 229

▼ To Install theSUNWSMSjh Package 229

▼ To Start smshelp 230

Glossary 237

Figures

FIGURE 2-1	Platform Administrator Privileges	17
FIGURE 2-2	Platform Operator Privileges	18
FIGURE 2-3	Platform Service Privileges	19
FIGURE 2-4	Domain Administrator Privileges	21
FIGURE 2-5	Domain Configurator Privileges	22
FIGURE 2-6	Superuser Privileges	23
FIGURE 3-1	Sun Fire High-End System Software Components	31
FIGURE 3-2	CODD Client Server relationships	35
FIGURE 3-3	DCA Client Server Relationships	36
FIGURE 3-4	DSMD Client Server Relationships	37
FIGURE 3-5	DXS Client Server Relationships	38
FIGURE 3-6	EFHD Client Server Relationships	39
FIGURE 3-7	ELAD Client Server Relationships	39
FIGURE 3-8	ERD Client Server Relationships	40
FIGURE 3-9	ESMD Client Server Relationships	41
FIGURE 3-10	FOMD Client Server Relationships	42
FIGURE 3-11	FRAD Client Server Relationships	43
FIGURE 3-12	HWAD Client Server Relationships	45
FIGURE 3-13	KMD Client Server Relationships	48
FIGURE 3-14	MAND Client Server Relationships	49

FIGURE 3-15	MLD Client Server Relationships	50
FIGURE 3-16	OSD Client Server Relationships	51
FIGURE 3-17	PCD Client Server Relationships	52
FIGURE 3-18	SSD Client Server Relationships	55
FIGURE 3-19	TMD Client Server Relationships	59
FIGURE 5-1	Automatic Diagnosis and Recovery Process for Hardware Errors Associated with a Stopped Domain	102
FIGURE 5-2	Automatic Diagnosis Process for Non-Fatal Domain Hardware Errors	105
FIGURE 5-3	Example Email Template and Generated Email	111
FIGURE 8-1	Management Network Overview	160
FIGURE 8-2	I1 Network Overview of the Sun Fire 15K	161
FIGURE 8-3	I2 Network Overview	162
FIGURE 8-4	External Network Overview	163
FIGURE 10-1	Failover Fault Categories	192

Tables

TABLE 2-1	All Group Privileges	24
TABLE 3-1	Daemons and Processes	32
TABLE 3-2	Example Environment Variables	60
TABLE 5-1	Event Tags in the Email Template File	110
TABLE 5-2	Email Control File Parameters	113
TABLE 5-3	<code>showlogs(1M)</code> Command Options for Displaying Error and Fault Event Information	118
TABLE 6-1	COD License Information	127
TABLE 6-2	<code>setupplatform</code> Command Options for COD Resource Configuration	129
TABLE 6-3	<code>showcodusage</code> Resource Information	134
TABLE 6-4	<code>showcodusage</code> Domain Information	135
TABLE 6-5	Obtaining COD Component, Configuration, and Event Information	140
TABLE 10-1	Failover Mechanisms	186
TABLE 11-1	SMS Log Type Information	201
TABLE 11-2	MLD Default Settings	204
TABLE B-1	Error Types	234
TABLE B-2	Error Categories	234

Preface

The *System Management Services (SMS) 1.4 Administrator Guide* describes the SMS software components of the Sun Fire™ high-end systems server system product line.

Before You Read This Book

This manual is intended for the Sun Fire system administrator, who has a working knowledge of UNIX® systems, particularly those based on the Solaris™ Operating Environment. If you do not have such knowledge, read the Solaris User and System Administrator documentation provided with this system, and consider UNIX system administration training.

All members of the next-generation Sun Fire server family can be configured as loosely coupled clusters. However, it is currently outside of the scope of this document to address system management for Sun Fire high-end systems cluster configurations.

How This Book Is Organized

This guide contains the following chapters:

[Chapter 1](#) introduces the System Management Services software and describes its command line interfaces.

[Chapter 2](#) introduces security on the domains.

[Chapter 3](#) describes SMS domain internals and explains how to use them.

[Chapter 4](#) describes domain configuration.

[Chapter 5](#) describes the automatic diagnosis and domain recovery features.

[Chapter 6](#) describes Capacity on Demand (COD).

[Chapter 7](#) describes the control functions.

[Chapter 8](#) describes network services available and how to use them.

[Chapter 9](#) describes status monitoring.

[Chapter 10](#) describes system controller (SC) failover.

[Chapter 11](#) describes event monitoring.

[Chapter 12](#) describes SMS utilities for creating and restoring backups, configuring networks and user groups and upgrading SMS software.

[Appendix A](#) provides a list of SMS man pages.

[Appendix B](#) describes SMS error messages.

[Glossary](#) is a list of words and phrases and their definitions.

Using UNIX Commands

This document might not contain information on basic UNIX® commands and procedures such as shutting down the system, booting the system, and configuring devices. See the following for this information:

- Software documentation that you received with your system
- Solaris™ operating environment documentation, which is at

<http://docs.sun.com>

Typographic Conventions

Typeface or Symbol	Meaning	Examples
AaBbCc123	The names of commands, files, and directories; on-screen computer output	Edit your <code>.login</code> file. Use <code>ls -a</code> to list all files. % You have mail.
AaBbCc123	What you type, when contrasted with on-screen computer output	% su Password:
<i>AaBbCc123</i>	Book titles, new words or terms, words to be emphasized. Replace command-line variables with real names or values.	Read Chapter 6 in the <i>User's Guide</i> . These are called <i>class</i> options. To delete a file, type rm <i>filename</i> .

Shell Prompts

Shell	Prompt
C shell	<code>sc_name:sms-user:></code> or <code>domain_id:sms-user:></code>
C shell superuser	<code>sc_name:#</code> or <code>domain_id:#</code>
Bourne shell and Korn shell	<code>></code>
Bourne shell and Korn shell superuser	<code>#</code>

Related Documentation

Application	Title	Part Number
Release Notes	<i>System Management Services (SMS) 1.4 Release Notes</i>	817-3058-10
Overview Guide	<i>Sun Fire High-End Systems Software Overview Guide</i>	817-3075-10
Installation	<i>System Management Services (SMS) 1.4 Installation Guide</i>	817-3055-10
Reference (man pages)	<i>System Management Services (SMS) 1.4 Reference Manual</i>	817-3057-10
Options	<i>System Management Services (SMS) 1.4 Dynamic Reconfiguration User Guide</i>	
	<i>Sun Fire 15K/12K Dynamic Reconfiguration User Guide</i>	816-5075-12
	<i>System Administration Guide: IP Services</i>	806-4075-11
	<i>OpenBoot™ 4.x Command Reference Manual</i>	816-1177-10
	<i>Sun Fire 15K/12K System Site Planning Guide</i>	806-3510-12
	<i>Sun Fire Link™ Fabric Administrator's Guide</i>	806-1405-10
	<i>Securing the Sun Fire 12K and 15K System Controllers: Updated for SMS 1.4</i>	817-1358-10
<i>Securing the Sun Fire 12K and 15K Domains: Updated for SMS 1.4</i>	817-1357-10	

Accessing Sun Documentation

You can view, print, or purchase a broad selection of Sun documentation, including localized versions, at:

<http://www.sun.com/documentation>

Contacting Sun Technical Support

If you have technical questions about this product that are not answered in this document, go to:

<http://www.sun.com/service/contacting>

Sun Welcomes Your Comments

Sun is interested in improving its documentation and welcomes your comments and suggestions. You can submit your comments by going to:

<http://www.sun.com/hwdocs/feedback>

Please include the title and part number of your document with your feedback:

System Management Services (SMS) 1.4 Administrator Guide , part number 817-3056-10

Introduction to System Management Services

This manual describes the System Management Services (SMS) 1.4 software that is available with the Sun Fire high-end server system.

This chapter includes the following sections:

- [Sun Fire High-End Systems](#)
- [SMS Features](#)
- [System Architecture](#)
- [SMS Administration Environment](#)
- [Sun Management Center](#)

Sun Fire High-End Systems

Sun Fire high-end system is a member of the next-generation Sun Fire server family.

The system controller (SC) in Sun Fire high-end systems is a multifunction, Nordica- or Othello-based printed circuit board (PCB), which provides critical services and resources required for the operation and control of the Sun Fire system. In this book, the system controller is called the SC.

A Sun Fire high-end system is often referred to as the *platform*. System boards within the platform can be logically grouped together into separately bootable systems called *dynamic system domains*, or simply *domains*.

Up to 18 domains on the Sun Fire 15K, and up to 9 domains on the Sun Fire 12K can exist simultaneously on a single platform. (Domains are introduced in this chapter, and are described in more detail in [“SMS Configuration” on page 61.](#)) The system management services (SMS) software lets you control and monitor domains, as well as the platform itself.

The following list is an overview of the many services the SC provides for the Sun Fire system:

- Manages the overall system configuration.
- Acts as a boot initiator for its domains.
- Serves as the syslog host for its domains; note that an SC can still be a syslog client of a LAN-wide syslog host.
- Provides a synchronized hardware clock source.
- Sets up and configures dynamic domains.
- Monitors system environmental information, such as power supply, fan, and temperature status.
- Hosts field-replaceable unit (FRU) logging data.
- Provides redundancy and automated SC failover in dual SC configurations.
- Provides a default name service for the domains based on virtual hostids, and MAC addresses for the domains.
- Provides administrative roles for platform management.

Redundant SCs

There are two SCs within Sun Fire platform. The SC that controls the platform is referred to as the main SC, while the other SC acts as a backup and is called the spare SC. The software running on the SC monitors the SCs to determine when an automatic failover should be performed.

We strongly recommend that the two SCs have the same configuration. This duplication includes the Solaris operating environment, SMS software, security modifications, patch installations, and all other system configurations.

The failover functionality between the SCs is controlled by the daemons running on the main and spare SCs. These daemons communicate across private communication paths built into the Sun Fire platform. Other than the communication of these daemons, there is no special trust relationship between the two SCs.

SMS software packages are installed on the SC. In addition, SMS communicates with the Sun Fire high-end system over an Ethernet connection, see [“Management Network Services” on page 165](#).

Note – SMS 1.4 cannot communicate with SMS 1.3 across the I2 network. If one of the SC’s is running SMS 1.3 and the other is running SMS 1.4, the I2 network tests will fail, and the SC’s will communicate through HASRAM. For information about the I2 network, see [“I2 Network” on page 162](#).

SMS Features

SMS 1.4 supports Sun Fire high-end servers running the Solaris 8 and Solaris 9 operating environments.

Note – SMS 1.3 is available for Solaris 8 02/02 software. That version will *not* run on Solaris 9 software without replacing specific driver packages. Conversely, the Solaris 9 version of SMS 1.4 will not run on Solaris 8 02/02 software without replacing specific driver packages. For more information contact your Sun service representative.

SMS 1.4 is compatible with Sun Fire high-end system domains that are running the Solaris 8 02/02 through Solaris 9 operating environment. The commands provided with the SMS software can be used remotely.

Note – Graphical user interfaces for many of the commands in SMS are provided by Sun Management Center. For more information, see [“Sun Management Center” on page 11](#).

SMS enables the platform administrator to perform the following tasks:

- Administer domains by logically grouping domain configurable units (DCU) together. DCUs are system boards such as CPU and I/O boards. Domains are able to run their own operating systems and handle their own workloads. See [“SMS Configuration” on page 61](#).
- Dynamically reconfigure a domain so that currently installed system boards can be *logically* attached to or detached from the operating system while the domain continues running in multiuser mode. This feature is known as *dynamic reconfiguration* and is described in the *System Management Services (SMS) 1.4 Dynamic Reconfiguration User Guide* (A system board can be *physically* swapped in and out when it is not attached to a domain, while the system continues running in multiuser mode.)
- Perform automatic dynamic reconfiguration of domains using a script. Refer to the *System Management Services (SMS) 1.4 Dynamic Reconfiguration User Guide*.
- Monitor and display the temperatures, currents, and voltage levels of one or more system boards or domains.
- Monitor and control power to the components within a platform.
- Execute diagnostic programs such as power-on self-test (POST).

In addition, SMS:

- Warns you of impending problems, such as high temperatures or malfunctioning power supplies.
- Notifies you when a software error or failure has occurred.
- Monitors a dual SC configuration for single points of failure and performs an automatic failover from the main SC to the spare depending on the failure condition detected.
- Automatically reboots a domain after a system software failure (such as a panic).
- Keeps logs of interactions between the SC environment and the domains.
- Provides support for the Sun Fire high-end system dual grid power option.

SMS enables the domain administrator to perform the following tasks:

- Administrate domains by logically grouping *domain configurable units* (DCU) together. DCUs are system boards such as: CPU and I/O boards. Domains are able to run their own operating systems and handle their own workloads. See [“SMS Configuration” on page 61](#).
- Boot domains for which the administrator has privileges.
- Dynamically reconfigure a domain for which the administrator has privileges, so that currently installed system boards can be *logically* attached to or detached from the operating system while the domain continues running in multiuser mode. This feature is known as *dynamic reconfiguration* and is described in the *System Management Services (SMS) 1.4 Dynamic Reconfiguration User Guide*. (A system board can be *physically* swapped in and out when it is not attached to a domain, while the system continues running in multiuser mode.)
- Perform automatic dynamic reconfiguration of domains using a script for which the administrator has privileges. Refer to the *System Management Services (SMS) 1.4 Dynamic Reconfiguration User Guide*.
- Monitor and display the temperatures, currents, and voltage levels of one or more system boards or domains for which the administrator has privileges.
- Execute diagnostic programs such as power-on self-test (POST) for which the administrator has privileges.

The following features are provided in this release of SMS:

- Dynamic system domain (DSD) configuration
- Configured domain services
- Domain control capabilities
- Automatic diagnosis and domain recovery
- Capacity on demand (COD)
- Domain status reporting
- Hardware control capabilities
- Hardware status monitoring, reporting, and handling
- Hardware error monitoring, reporting, and handling
- System controller (SC) failover
- Configurable administrative privileges

- Dynamic FRUID

System Architecture

SMS architecture is best described as distributed client-server. `init(1M)` starts (and restarts as necessary) one process: `ssd(1M)`. `ssd` is responsible for monitoring all other SMS processes and restarting them as necessary. See [FIGURE 3-1](#).

The Sun Fire high-end systems platform, the SC, and other workstations communicate over Ethernet. You perform SMS operations by entering commands on the SC console after remotely logging in to the SC from another workstation on the local area network. You must log in as a user with the appropriate platform or domain privileges if you want to perform SMS operations (such as monitoring and controlling the platform).

Note – If SMS is stopped on the main SC and the other SC is powered off, the domains gracefully shutdown and the platform is powered down. If the remaining SC is simply powered off without a shutdown of SMS, SMS won't have time to power off the platform and the domains will crash.

Dual system controllers are supported within the Sun Fire high-end systems platform. One SC is designated as the primary or main system controller, and the other is designated as the spare system controller. If the main SC fails, the failover capability automatically switches to the spare SC as described in [“SC Failover” on page 179](#).

Most domain configurable units are active components and you need to check the system state before powering off any DCU.

Note – Circuit breakers must be on whenever a board is present, including expander boards, whether or not the board is powered on.

For details, see [“Power Control” on page 153](#).

SMS Administration Environment

Administration tasks on the Sun Fire high-end system are secured by group privilege requirements. Upon installation, SMS installs the following 39 UNIX groups to the `/etc/group` file.

- `platadm` - Platform administrator
- `platooper` - Platform operator
- `platsvc` - Platform service
- `dmn[A...R]adm` - domain `[domain_id|domain_tag]` administrator (18)
- `dmn[A...R]rcfg` - domain `[domain_id|domain_tag]` configurator (18)

`smsconfig(1M)` allows an administrator to add, remove, and list members of platform and domain groups as well as set platform and domain directory privileges using the `-a`, `-r`, and `-l` options.

`smsconfig` also can configure SMS to use alternate group names including NIS managed groups using the `-g` option. Group information entries can come from any of the sources for groups specified in the `/etc/nsswitch.conf` file (refer to `nsswitch.conf(4)`). For instance, if domain A was known by its domain tag as the "Production Domain," an administrator could create a NIS group with the same name and configure SMS to use this group as the domain A administrator group instead of the default, `dmnaadm`. For more information, refer to the *System Management Services (SMS) 1.4 Installation Guide*, "[Administration Privileges](#)" on [page 15](#), and refer to the `smsconfig` man page.

Network Connections for Administrators

The nature of the Sun Fire high-end systems physical architecture, with an embedded system controller, as well as the supported administrative model (with multiple administrative privileges, and hence multiple administrators) dictates that an administrator utilize a remote network connection from a workstation to access SMS command interfaces to manage the Sun Fire high-end system.



Caution – Shutting down a remote workstation while a tip session is active into a Sun Fire high-end system SC will bring both SCs down to the OpenBoot OK prompt. This will not affect the domains and after powering the remote system back on you can restore the SCs by typing `go` at the OK prompt; however, you should end all tip sessions before shutting down a remote workstation.

Since the administrators provide information to verify their identity (passwords) and might possibly need to display sensitive data, it is important that the remote network connection be secure. Physical separation of the administrative networks provides some security on the Sun Fire high-end system. Multiple external physical network connections are available on each SC. SMS software supports up to two external network communities.

For more information on Sun Fire high-end system networks, see [“Management Network Services” on page 165](#). For more information on securing the Sun Fire high-end system see [“Security Options” on page 14](#).

SMS Operating Environment

You can interact with the SC and the domains on the Sun Fire high-end system by using SMS commands.

SMS provides a command-line interface to the various functions and features it contains.

▼ To Begin Using the SC

1. Boot the SC.

For the examples in this guide, the *sc_name* is *sc0* and *sms-user* is the *user-name* of the administrator, operator, configurator, or service personnel logged onto the system.

The privileges allotted to the user are determined by the platform or domain groups to which the user belongs. In these examples, the *sms-user* is assumed to have both platform and domain administrator privileges, unless otherwise noted.

For more information on the function and creation of SMS user groups, refer to the *System Management Services (SMS) 1.4 Installation Guide* and see [“Administration Privileges” on page 15](#).

Note – This procedure assumes that `smsconfig -m` has already been run. If `smsconfig -m` has not been run, you will receive the following error when SMS attempts to start and SMS will exit.

```
sms: smsconfig(1M) has not been run. Unable to start sms services.
```

2. Log in to the SC and verify that SMS software startup has completed. Type:

```
sc0:sms-user:> showplatform
```

3. **Wait until `showplatform` finishes displaying platform status.**

At this point you can begin using SMS programs.

SMS Console Window

An SMS console window provides a command-line interface from the SC to the Solaris operating environment on the domain(s).

▼ To Display a Console Window Locally

1. **Log in to the SC, if you have not already done so.**

Note – You must have domain privileges for the domain on which you wish to run console.

2. Type:

```
sc0:sms-user:> console -d domain_indicator option
```

where:

- d Specifies the domain using a *domain_indicator*:

domain_id - ID for a domain. Valid *domain_ids* are 'A'...'R' and are case insensitive.

domain_tag - Name assigned to a domain using `addtag(1M)`.
- f Force
Opens a domain console window with "locked write" permission, terminates all other open sessions, and prevents new ones from being opened. This constitutes an "exclusive session." Use it only when you need exclusive use of the console (for example, for private debugging). To restore multiple-session mode, either release the lock (~^) or terminate the console session (~.).
- g Grab
Opens a console window with "unlocked write" permission. If another session has "unlocked write" permission, the new console window takes it away. If another session has "locked" permission, this request is denied and a read-only session is started.
- l Lock
Opens a console window with "locked write" permission. If another session has "unlocked write" permission, the new console window takes it away. If another session has "locked" permission, the request is denied and a read-only session is started.
- r Read Only
Opens a console window in read-only mode

`console` creates a remote connection to the domain's virtual `console` driver, making the window in which the command is executed a "console window" for the specified domain (*domain_id* or *domain_tag*).

If `console` is invoked without any options when no other console windows are running for that domain, it comes up in exclusive "locked write" mode session.

If `console` is invoked without any options when one or more non-exclusive console windows are running for that domain, it will come up in "read-only" mode.

Locked write permission is more secure. It can only be taken away if another console is opened using `console -f` or if ~*(tilde-asterisk) is entered from another running console window. In both cases, the new console session is an "exclusive

session", and all other sessions are forcibly detached from the domain virtual console.

`console` can utilize either Input Output Static Random Access Memory (IOSRAM) or the internal management network for domain console communication. You can manually toggle the communication path by using the `~=` (tilde-equal sign) command. Doing so is useful if the network becomes inoperable, in which case the console sessions appears to be hung.

Many console sessions can be attached simultaneously to a domain, but only one console will have write permissions; all others will have read-only permissions. Write permissions are in either "locked" or "unlocked" mode.

Tilde Usage

In a domain console window, a tilde (`~`) that appears as the first character of a line is interpreted as an escape signal that directs console to perform some special action, as follows:

Character	Description
<code>~?</code>	Status message
<code>~.</code>	Disconnects console session
<code>~#</code>	Breaks to OpenBoot™ PROM or <code>kadb</code>
<code>~@</code>	Acquires unlocked write permission. See option <code>-g</code>
<code>~^</code>	Releases write permission
<code>~=</code>	Toggles the communication path between the network and IOSRAM interfaces. You can use <code>~=</code> only in private mode (see <code>~*</code>).
<code>~&</code>	Acquires locked write permission; see option <code>-l</code> . You may issue this signal during a read-only or unlocked write session.
<code>~*</code>	Acquires locked write permission, terminates all other open sessions, and prevent new sessions from being opened; see option <code>-f</code> . To restore multiple-session mode, either release the lock or terminate this session.

`rlogin` also processes tilde-escape sequences whenever a tilde is seen at the beginning of a new line. If you need to send a tilde sequence at the beginning of a line and you are connected using `rlogin`, use two tildes (the first escapes the second for `rlogin`). Alternatively, do not enter a tilde at the beginning of a line when running inside of an `rlogin` window.

If you use a `kill -9` command to terminate a console session, the window or terminal in which the `console` command was executed goes into raw mode, and appears hung. Type `CTRL-j`, then `stty sane`, then `CTRL-j` to escape this condition,

In the domain console window, `vi(1)` runs properly and the escape sequences (tilde commands) work as intended only if the environment variable `TERM` has the same setting as that of the console window.

For example:

```
sc0:sms-user:> setenv TERM xterm
```

If you need to resize the window, type:

```
sc0:sms-user:> stty rows 20 cols 80
```

For more information on domain console, see [“Domain Console” on page 165](#) and refer to the `console` man page.

Remote Console Session

In the event that a system controller hangs and that console cannot be reached directly, SMS provides the `smsconnectsc` command to remotely connect to the hung SC. This command works from either the main or spare SC. For more information and examples, refer to the `smsconnectsc` man page.

Your other option is to connect to the hung SC using an external console connection but you cannot run `smsconnectsc` and use an external console at the same time.

Sun Management Center

Sun Management Center for Sun Fire high-end systems is an extensible monitoring and management tool that provides a system administrator with the ability to manage the Sun Fire high-end system. Sun Management Center integrates standard SNMP based management structures with new intelligent and autonomous agent and management technology based on the client/ server paradigm.

Sun Management Center is used as the GUI and SNMP manager/agent infrastructure for the Sun Fire system. The features and functions of Sun Management Center are not covered in this manual. For more information, refer to the latest Sun Management Center documentation available at www.docs.sun.com.

SMS Security Options and Administrative Privileges

This chapter provides a brief overview of security and administrative privileges as they pertain to SMS and the Sun Fire high-end server system.

The Sun Fire high-end system platform hardware can be partitioned into one or more environments capable of running separate images of the Solaris operating environment. These environments are called *dynamic system domains* (DSD)s or *domains*.

A domain is logically equivalent to a physically separate server. The Sun Fire high-end system hardware has been designed to enforce strict separation of the domain environments. This means that, except for errors in hardware shared by multiple domains, no hardware error in one domain affects another. In order for domains to act like separate servers, Sun Fire software was designed and implemented to enforce strict domain separation.

SMS provides services to all DSDs. In providing those services, no data obtained from one client DSD is leaked into data observable by another. This is particularly true for sensitive data such as buffers of console characters (including administrator passwords) or potentially sensitive data such as I/O buffers containing client DSD-owned data.

SMS limits administrator privilege to control the extent of damage that can occur due to administrator error, as well as to limit the exposure to damage caused by an external attack on a system password.

This chapter includes the following sections:

- [Security Options](#)
- [Administration Privileges](#)

Security Options

The following security options are available in SMS 1.4:

Strongly Recommended

- Use Secure Shell (`ssh`) as an alternative transport for `fomd` (failover management daemon).
- Disable ARP (Address Resolution Protocol) on the I1 MAN network between the SCs and domains.

Optional

- Disable all IP traffic between the SC and a domain by excluding that domain from the SC's MAN driver.

By using `ssh` as an alternative transport for `fomd`, the SCs no longer require a `/.rhosts` file. Secure Shell provides user authentication and encrypts all network traffic; it prevents an intruder from being able to read an intercepted communication or from spoofing the system.

To protect against ARP spoofing and IP-based attacks, We strongly recommend that you disable ARP on the MAN network in all multi-domain configurations. For systems where domain separation is critical, we also recommend disabling IP connectivity between the SC and specific domains that require separation.

Before you implement the above security options, we strongly recommend that you modify (harden) your Solaris operating environment configurations on the SCs and domains to improve overall system security. For details, refer to following Sun BluePrints Online articles available at:

<http://www.sun.com/security/blueprints>

- Solaris Operating Environment Security - Updated for Solaris 8 Operating Environment
- Solaris Operating Environment Security - Updated for Solaris 9 Operating Environment

For step-by-step instructions on implementing the three options, which involve the use of the Solaris Security Toolkit (SST, a.k.a JASS), and detailed description of all security recommendations for Sun Fire high-end systems, refer to the following Sun BluePrints Online articles available at:

<http://www.sun.com/security/blueprints>

- Securing the Sun Fire 12K and 15K System Controllers: Updated for SMS 1.4
- Securing the Sun Fire 12K and 15K Domains: Updated for SMS 1.4

Administration Privileges

SMS splits domain and platform administrative privileges. It is possible to assign separate administrative privileges for system management over each domain and for system management over the entire platform. There is also a subset of privileges available for platform operator and domain configurator-class users. Administrative privileges are granted so that audits can identify the individual who initiated any action.

SMS uses site-established Solaris user accounts and grants administrative privileges to those accounts through the use of Solaris *group* memberships. This allows a site considerable flexibility with respect to creating and consolidating default privileges. For example, by assigning the same Solaris group to represent the administrator privilege for more than one domain, groups of domains can be administered by one set of domain administrators.

SMS also allows the site considerable flexibility in assigning multiple administrative roles to individual administrators. A single user account with group membership in the union of all configured administrative privilege groups can be set up.

The platform administrator has control over the platform hardware. Limitations have been established with respect to controlling the hardware used by a running domain, but ultimately the platform administrator can shut down a running domain by powering off server hardware.

Each domain administrator has access to the Solaris console for that domain and the privilege to exert control over the software that runs in the domain or over the hardware assigned to the domain.

Levels of each type of administrative privilege provide a subset of status and monitoring privileges to a platform operator or domain configurator.

SMS provides an administrative privilege that grants access to functions provided exclusively for servicing the product in the field.

Administrative privilege configuration can be changed at will, by the superuser, using `smsconfig -g` without the need to stop or restart SMS.

SMS implements Solaris access control list (ACL) software to configure directory access for SMS groups using the `-a` and `-r` options of the `smsconfig` command. ACLs restrict access to platform and domain directories providing file system security. For information on ACLs, refer to the *Solaris 9 System Administration Guide: Security Services*.

Platform Administrator Group

The group identified as the platform administrator (`platadm`) group provides configuration control, a means to get environmental status, the ability to assign boards to domains, power control, and other generic service processor functions. In short, the platform administrator group has all platform privileges excluding domain control and access to installation and service commands ([FIGURE 2-1](#)).

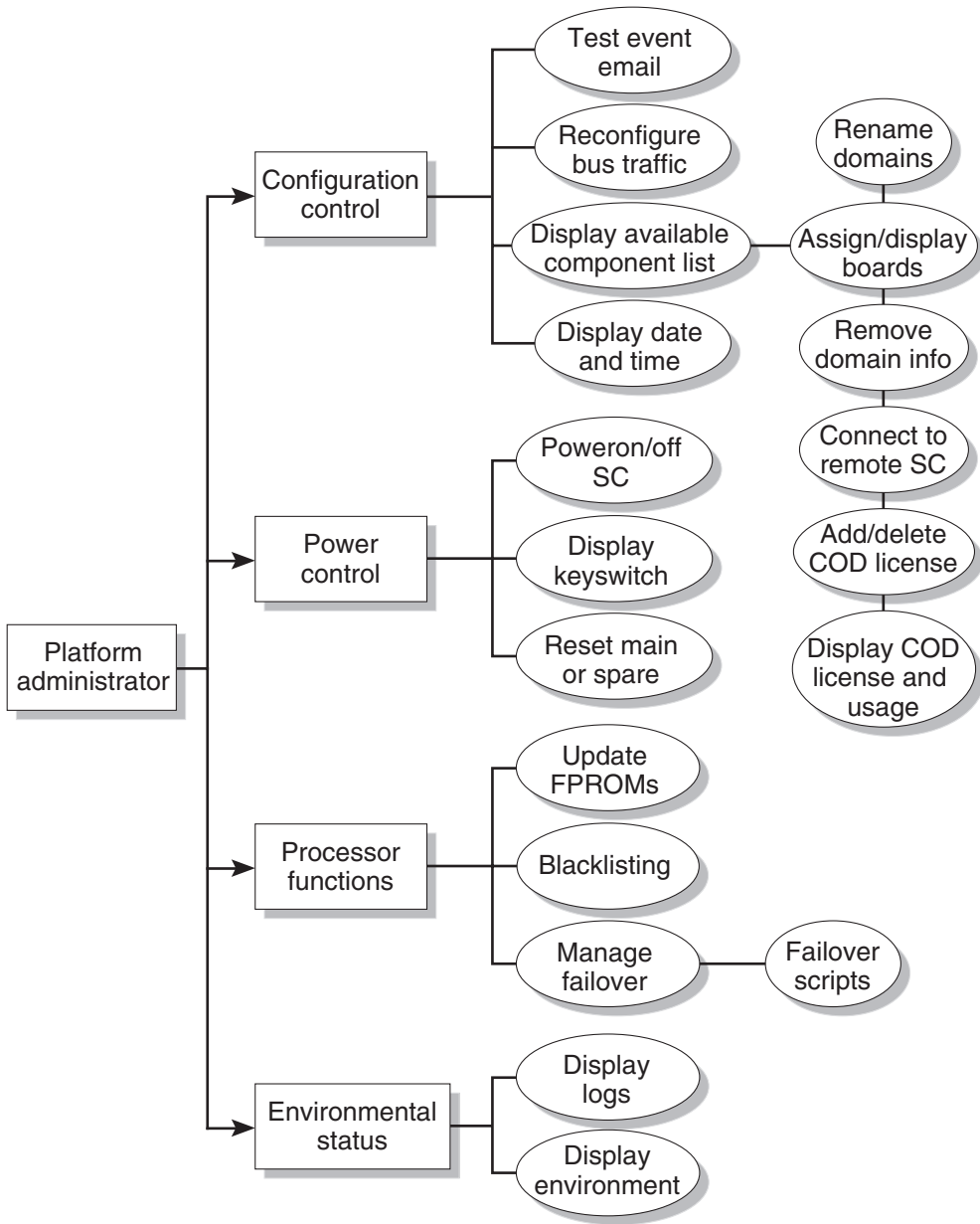

FIGURE 2-1 Platform Administrator Privileges

Platform Operator Group

The platform operator (`platoper`) group has a subset of platform privileges. This group has no platform control other than being able to perform power control. Therefore, this group is limited to platform power and status privileges (FIGURE 2-2).

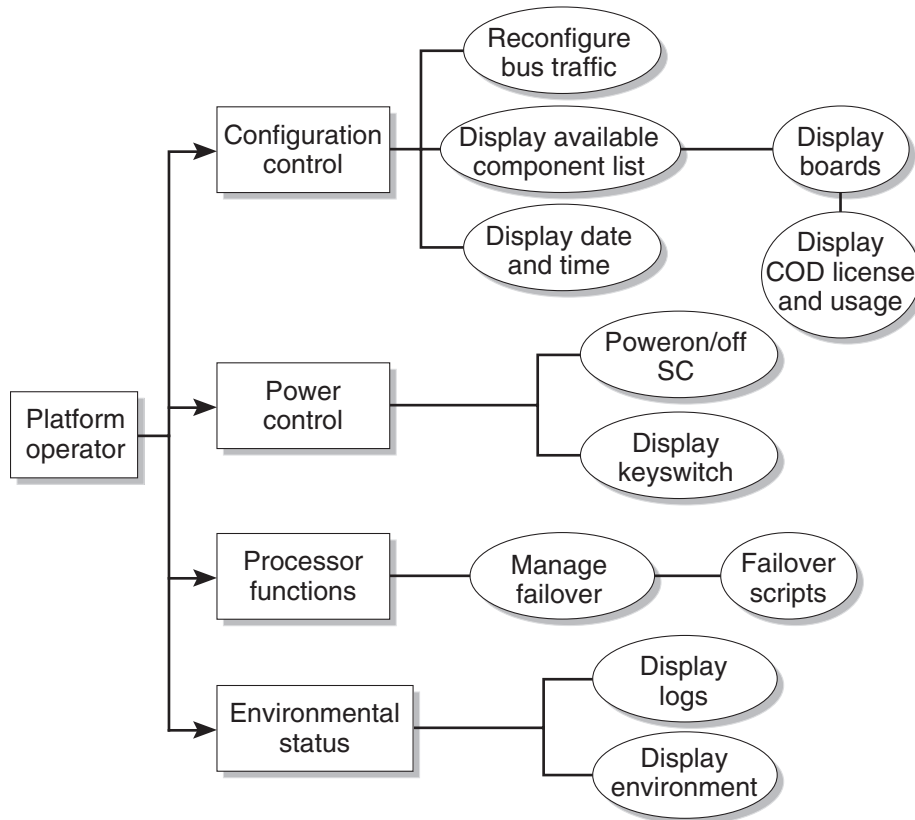

FIGURE 2-2 Platform Operator Privileges

Platform Service Group

The platform service (`platsvc`) group possesses platform service command privileges in addition to limited platform control and platform configuration status privileges (FIGURE 2-3).

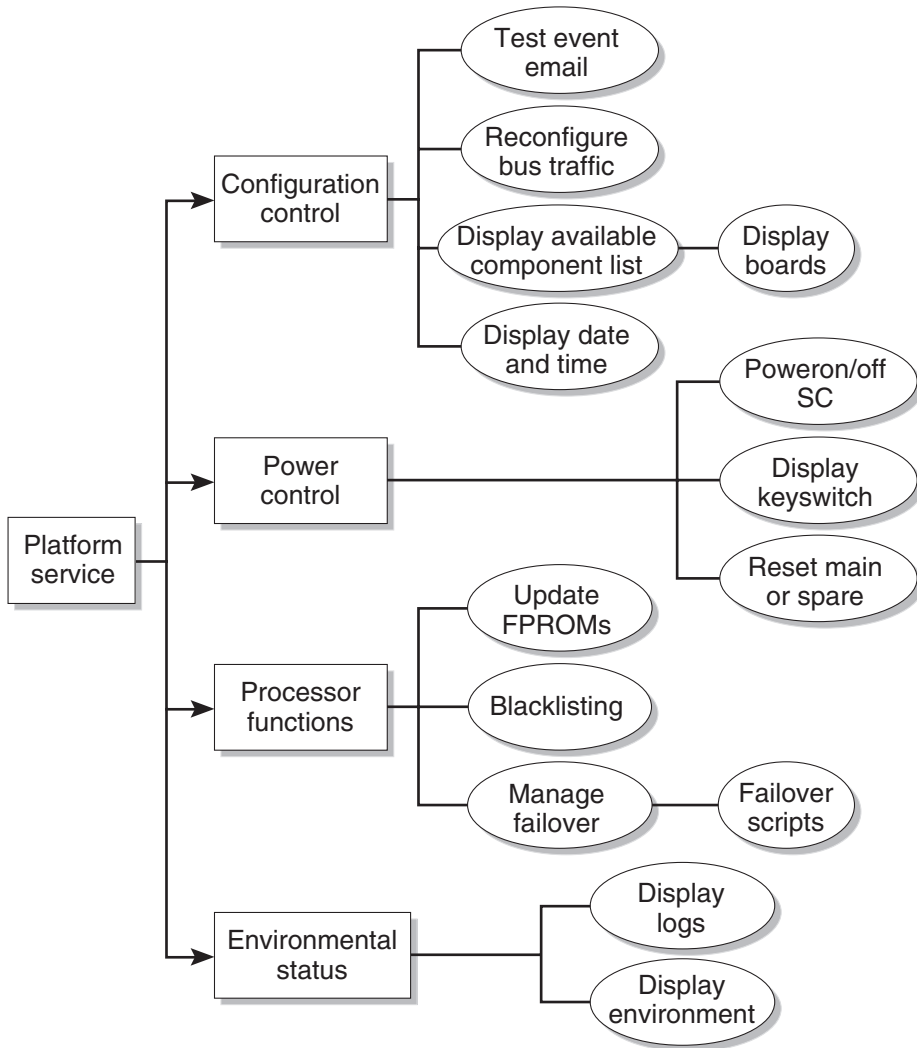

FIGURE 2-3 Platform Service Privileges

Domain Administrator Group

The domain administrator (`dmn[domain_id]admin`) group provides the ability to access the console of its respective domain as well as perform other operations that affect, directly or indirectly, the respective domain. Therefore, the domain administrator group can perform domain control, domain status, and console access, but cannot perform platform wide control or platform resource allocation (FIGURE 2-4).

There are 18 possible Sun Fire domains, A-R, identified by *domain_id*. Therefore, there are 18 Domain Administrator groups, each providing strict access over their respective domains.

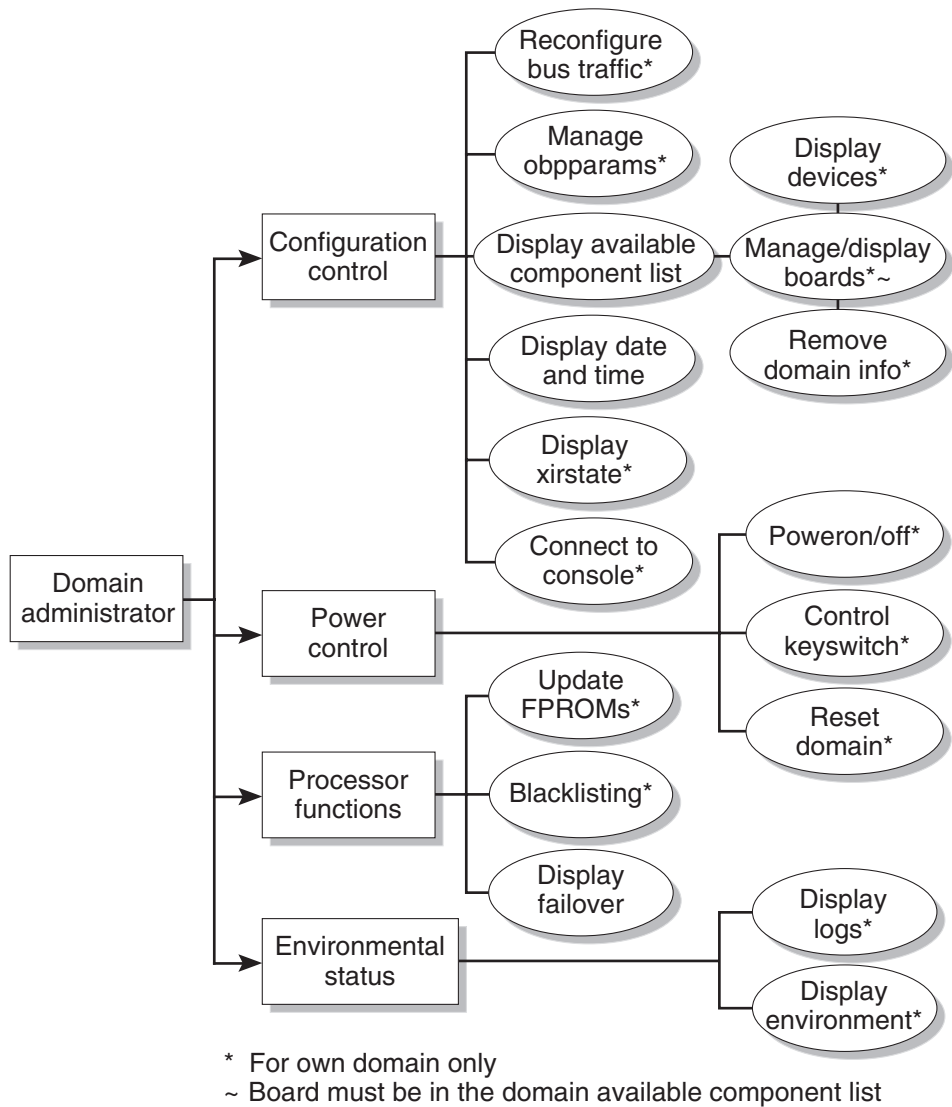
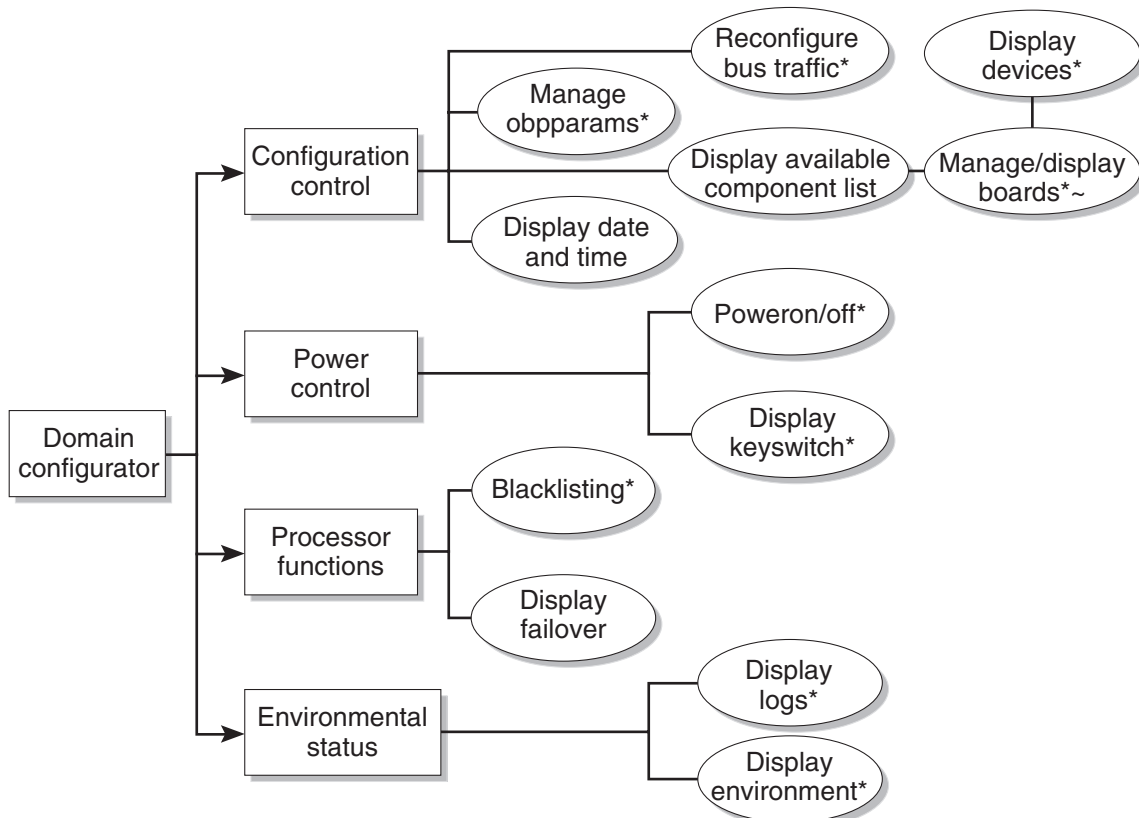

FIGURE 2-4 Domain Administrator Privileges

Domain Configuration Group

The domain configuration (`dmn[domain_id]rcfg`) group has a subset of domain administration group privileges. This group has no domain control other than being able to power control boards in its domain or (re)configure boards into or from its domain (FIGURE 2-5).

There are 18 possible Sun Fire domains identified by *domain_ids*. Therefore, there are 18 domain configuration groups, each allowing strict access over their respective domains.



* For own domain only

~ Board must be in the domain available component list

FIGURE 2-5 Domain Configurator Privileges

Superuser Privileges

The superuser privileges are limited to installation, help, and status privileges (FIGURE 2-6).

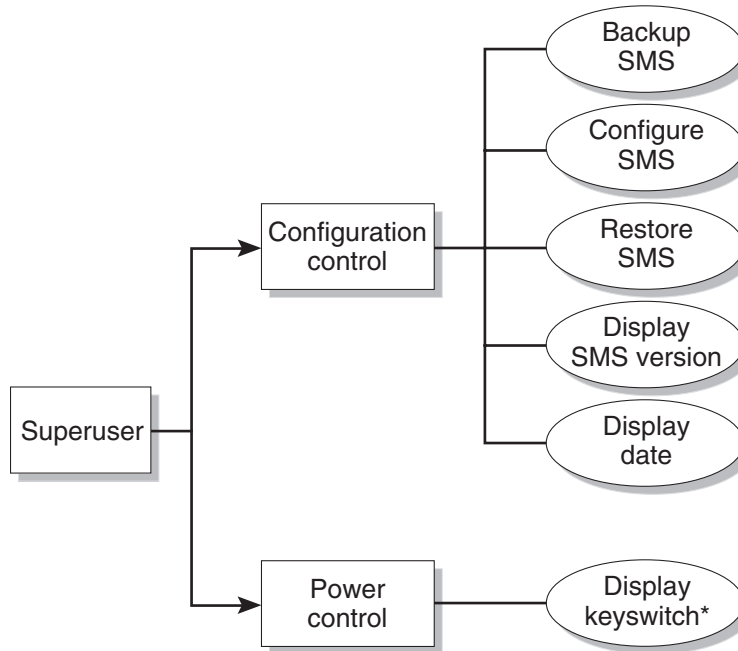

FIGURE 2-6 Superuser Privileges

All Privileges

The following is a list of all group privileges.

TABLE 2-1 All Group Privileges

Command	Group Privileges					
	Platform Administrator	Platform Operator	Domain Administrator	Domain Configurator	Platform Service	Superuser
addboard	A user with only platform administrator privileges can perform only the <i>-c assign</i> .	No	Users with only domain X administrator privileges can execute this command on their respective domain. If the board(s) are not already assigned to the domain, the board(s) must be in the available component list of that domain.	Users with only domain X configurator privileges can execute this command on their respective domain. If the board(s) are not already assigned to the domain, the board(s) must be in the available component list of that domain.	No	No
addcodlicense	Yes	No	No	No	No	No
addtag	Yes	No	No	No	No	No
cancelcmdsyc	Yes	Yes	Yes	Yes	Yes	No
console	No	No	Yes (for own domain)	No	No	No

TABLE 2-1 All Group Privileges (*Continued*)

Command	Group Privileges					
	Platform Administrator	Platform Operator	Domain Administrator	Domain Configurator	Platform Service	Superuser
deleteboard	A user with only platform administrator privileges can perform <code>-c unassign</code> only if the board(s) are in the <i>assigned</i> state and not active in a running domain.	No	Users with only domain X administrator privileges can execute this command on their respective domain. If the board(s) are not already assigned to the domain, the board(s) must be in the available component list of that domain.	Users with only domain X configurator privileges can execute this command on their respective domain. If the board(s) are not already assigned to the domain, the board(s) must be in the available component list of that domain.	No	No
deletecodlicense	Yes	No	No	No	No	No
deletetag	Yes	No	No	No	No	No
disablecomponent	Yes (platform only)	No	Yes (for own domain)	Yes (for own domain)	No	No
enablecomponent	Yes (platform only)	No	Yes (for own domain)	Yes (for own domain)	No	No
flashupdate	Yes	No	Yes (for own domain)	No	No	No
help	Yes	Yes	Yes	Yes	Yes	Yes
initcmdsync	Yes	Yes	Yes	Yes	Yes	No

TABLE 2-1 All Group Privileges (*Continued*)

Command	Group Privileges					
	Platform Administrator	Platform Operator	Domain Administrator	Domain Configurator	Platform Service	Superuser
moveboard	A user with only platform administrator privileges can perform the <i>-c assign</i> only if the board is in the <i>assigned</i> state and not active in the domain the board is being removed from.	No	Users must belong to both domains affected. If the board(s) are not already assigned to the domain the board(s) are being moved into, the board(s) must be in the available component list of that domain.	Users must belong to both domains affected. If the board(s) are not already assigned to the domain the board(s) is being moved into, the board(s) must be in the available component list of that domain.	No	No
poweron	Yes	No	Yes (for own domain)	Yes (for own domain)	No	No
poweroff	Yes	No	Yes (for own domain)	Yes (for own domain)	No	No
rcfgadm	A user with only platform administrator privileges can perform <i>-x assign</i> . The user can execute <i>-x unassign</i> only if the board(s) are in the <i>assigned</i> state and not active in a running domain.	No	Users with only domain X administrator privileges can execute this command on their respective domain. If the board(s) are not already assigned to the domain, the board(s) must be in the available component list of that domain.	Users with only domain X configurator privileges can execute this command on their respective domain. If the board(s) are not already assigned to the domain, the board(s) must be in the available component list of that domain.	No	No
reset	No	No	Yes (for own domain)	No	No	No

TABLE 2-1 All Group Privileges (*Continued*)

Command	Group Privileges					
	Platform Administrator	Platform Operator	Domain Administrator	Domain Configurator	Platform Service	Superuser
resetsc	Yes	No	No	No	No	No
runcmdsync	Yes	Yes	Yes	Yes	Yes	No
savecmdsync	Yes	Yes	Yes	Yes	Yes	No
setbus	Yes	No	Yes (for own domain)	Yes (for own domain)	No	No
setcsn	Yes	No	No	No	Yes	No
setdatasync	Yes	Yes	Yes	Yes	Yes	No
setdate	Yes	No	Yes (for own domain)	No	No	No
setdefaults	Yes	No	Yes (for own domain)	No	No	No
setfailover	Yes	No	No	No	No	No
setkeyswitch	No	No	Yes (for own domain)	No	No	No
setobpparams	No	No	Yes (for own domain)	Yes (for own domain)	No	No
setupplatform	Yes	No	No	No	No	No
showboards	Yes	Yes	Yes (for own domain)	Yes (for own domain)	Yes	No
showbus	Yes	Yes	Yes (for own domain)	Yes (for own domain)	Yes	No
showcmdsync	Yes	Yes	Yes	Yes	Yes	No
showcodlicense	Yes	Yes	No	No	No	No
showcodusage	Yes	Yes	No	No	No	No
showcomponent	Yes	Yes	Yes (for own domain)	Yes (for own domain)	Yes	No
showdatasync	Yes	Yes	Yes	Yes	Yes	No
showdate	Yes (platform only)	Yes (platform only)	Yes (for own domain)	Yes (for own domain)	Yes (platform only)	No
showdevices	No	No	Yes (for own domain)	Yes (for own domain)	No	No

TABLE 2-1 All Group Privileges (*Continued*)

Command	Group Privileges					
	Platform Administrator	Platform Operator	Domain Administrator	Domain Configurator	Platform Service	Superuser
showenvironment	Yes	Yes	Yes (for own domain)	Yes (for own domain)	Yes	No
showfailover	Yes	Yes	No	No	Yes	No
showkeyswitch	Yes	Yes	Yes (for own domain)	Yes (for own domain)	Yes	No
showlogs	Yes (platform only)	Yes (platform only)	Yes (for own domain)	Yes (for own domain)	Yes (platform only)	No
showobpparams	No	No	Yes (for own domain)	Yes (for own domain)	No	No
showplatform	Yes	Yes	Yes (for own domain)	Yes (for own domain)	Yes	No
showxirstate	No	No	Yes (for own domain)	No	No	No
smsbackup	No	No	No	No	No	Yes
smsconfig	No	No	No	No	No	Yes
smsconnectsc	Yes	No	No	No	No	No
smsrestore	No	No	No	No	No	Yes
smsversion	No	No	No	No	No	Yes
testemail	Yes	No	No	No	Yes	No

SMS Internals

SMS operations are generally performed by a set of daemons and commands. This chapter provides an overview of how SMS works and describes the SMS daemons, processes, commands, and system files. For more information, refer to the *System Management Services (SMS) 1.4 Reference Manual*.



Caution – Changes made to files in `/opt/SUNWSMS` can cause serious damage to the system. Only very experienced system administrators should risk changing the files described in this chapter.

This chapter includes the following sections:

- [Startup Flow](#)
- [SMS Daemons](#)

Startup Flow

The events that take place when the SMS boots are as follows:

1. User powers on the Sun Fire high-end (CPU/disk and CD-ROM) platform. The Solaris operating environment on the SC boots automatically.
2. During the boot process, the `/etc/init.d/sms` script is called. This script, for security reasons, disables forwarding, broadcast, and multicasting over the MAN network. It then starts the SMS software by invoking a background process, which starts and monitors `ssd`. `ssd` is the SMS startup daemon responsible for starting and monitoring all the SMS daemons and servers.
3. `ssd(1M)` in turn invokes: `mld`, `pcd`, `hwad`, `tmd`, `dsmd`, `esmd`, `mand`, `osd`, `dca`, `efe`, `codd`, `efhd`, `elad`, `erd`, `smnptd`, `picld`, and `wcapp`.

For more information, see “SMS Daemons” on page 30, and “Message Logging” on page 199. For `efe`, refer to the latest Sun Management Center documentation available at <http://docs.sun.com>.

4. Once the daemons are running, you can use SMS commands such as `console`.
SMS startup can take a few minutes during which time any commands run will return an error message indicating that SMS has not completed startup. The message “SMS software start-up complete” is posted to the platform log when startup is complete and can be viewed using the `showlogs(1M)` command.

SMS Daemons

The SMS 1.4 daemons play a central role on Sun Fire high-end systems. Daemons are persistent processes that provide SMS services to clients using an API.

Note – SMS daemons are started by `ssd` and should *not* be started manually from the command line. Issuing a `kill` command against any daemon will seriously affect the robustness of SMS software and should not be done unless specifically requested by Sun service personnel.

Daemons are always running, initiated at system startup, and restarted whenever necessary.

Each daemon is fully described in its corresponding man page (with the exception of `efe`, which is referenced separately in the Sun Management Center documentation).

This section looks at the SMS daemons, their relationship to one another, and includes which CLIs (if any) access them.

FIGURE 3-1 illustrates the Sun Fire high-end system software components and their high-level interaction.

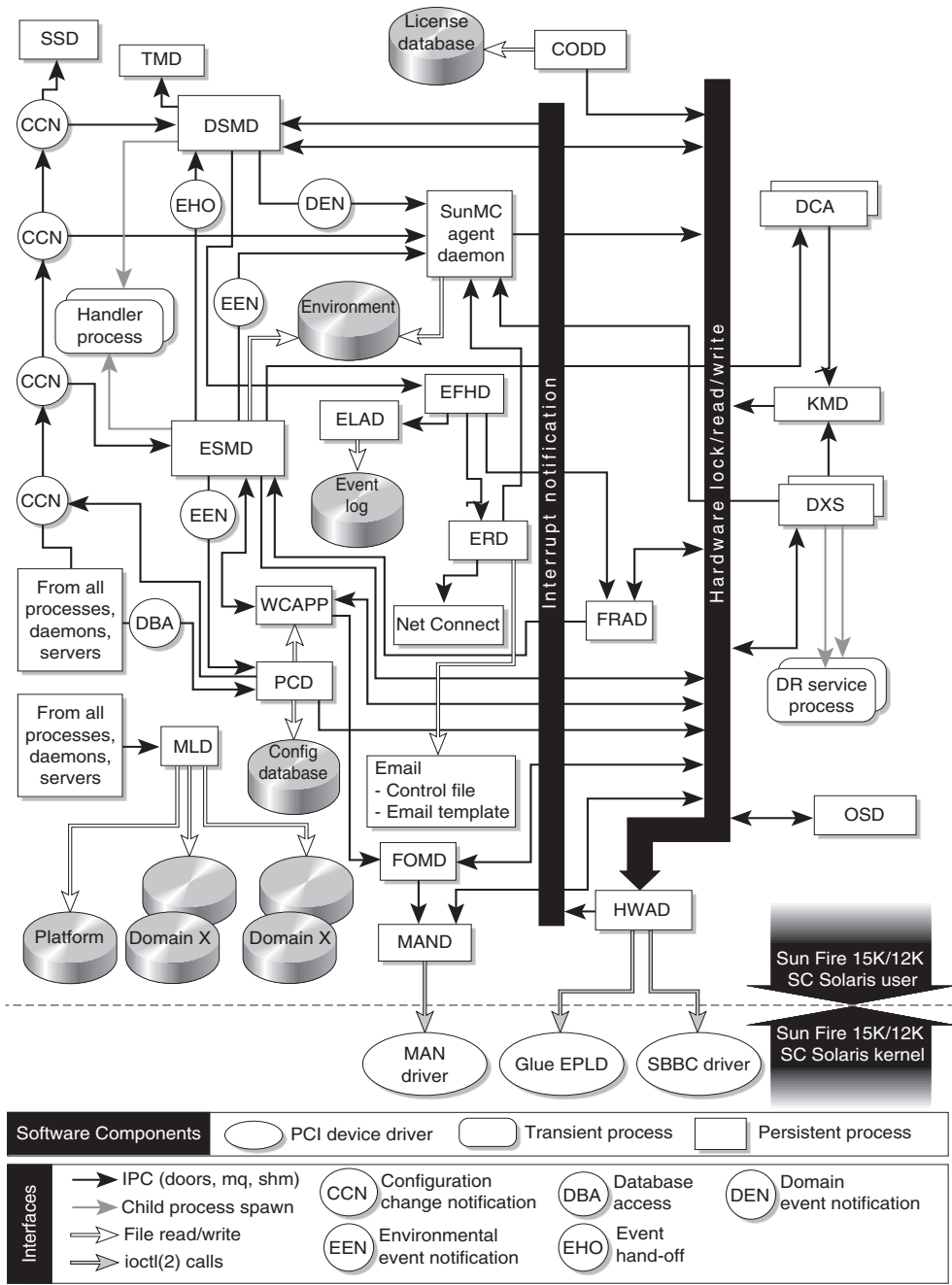

FIGURE 3-1 Sun Fire High-End System Software Components

Note – The domain X server (`dxs`) and domain configuration agent (`dca`), while not daemons, are essential server processes and included in the following table and section. There is an instance of `dxs` and `dca` running for each domain up to eighteen instances.

TABLE 3-1 Daemons and Processes

Daemon Name	Description
<code>codd</code>	The capacity on demand daemon monitors the COD resources being used and verifies that the resources used are in agreement with the licenses in the COD license database file. This daemon is started automatically by the SMS startup daemon.
<code>dca</code>	The domain configuration agent provides a communication mechanism between the <code>dca</code> on the system controller and the domain configuration server (<code>dcS</code>) on the specified domain. There is a separate instance of the <code>dca</code> daemon for every domain up to 18 domains. This daemon is started automatically by the SMS startup daemon.
<code>dsmD</code>	The domain status monitoring daemon monitors domain status, CPU reset conditions and the Solaris OE heartbeat for up to 18 domains on the Sun Fire 15K and up to nine on the Sun Fire 12K. This daemon is started automatically by the SMS startup daemon.
<code>dxs</code>	The domain X server provides software support for a domain including dynamic reconfiguration (DR), hot-pluggable PCI I/O assembly support, domain driver requests and events, and virtual console support. There is a separate instance of the <code>dxs</code> daemon for each domain up to 18 domains on the Sun Fire 15K and up to nine on the Sun Fire 12K. This daemon is started automatically by the SMS startup daemon.
<code>efe</code>	The event front end daemon is part of Sun Management Center and acts as an intermediary between the Sun Management Center agent and SMS. It is not covered further in this manual. For more information on <code>efe</code> , refer to the <i>Sun Management Center 3.5 Supplement for Sun Fire 15K/12K Systems</i> .
<code>efhd</code>	The error and fault handling daemon performs automatic error diagnosis and updates the component health status of components associated with a fault. This daemon is started automatically by the SMS startup daemon.
<code>elad</code>	The event log access daemon controls access to the SMS event log, which records fault and error events identified by the automatic diagnosis (AD) engine. This daemon also starts a new event log file whenever the current event log reaches its size limit and deletes the oldest archive file.

TABLE 3-1 Daemons and Processes (*Continued*)

Daemon Name	Description
erd	The event reporting daemon reports fault event messages to platform and domain logs, provides fault information to Sun Management Center and Sun SM Remote Services Net Connect, and delivers email reports that contain fault event messages. This daemon is started automatically by the SMS startup daemon.
esmd	The environmental status monitoring daemon monitors system cabinet environmental conditions, such as fan trays, power supplies, and temperatures. This daemon is started automatically by the SMS startup daemon.
fomd	The failover monitoring daemon detects faults on the local and remote SCs and takes appropriate action (directing or taking a failover.) This daemon is started automatically by the SMS startup daemon.
frad	The FRU access daemon provides the mechanism by which SMS daemons can access any field-replaceable unit (FRU) EEPROM on a Sun Fire high-end system. This daemon is started automatically by the SMS startup daemon.
hwad	The hardware access daemon provides hardware access to SMS daemons and a mechanism for all daemons to exclusively access, control, monitor, and configure the hardware. This daemon is started automatically by the SMS startup daemon.
km d	The key management daemon manages the IPSec security associations (SAs) needed to secure the communication between the system controller (SC) and servers running on a domain. This daemon is started automatically by the SMS startup daemon.
mand	The management network daemon supports the MAN drivers, providing required network configuration. The role played by mand is specified by the fomd. This daemon is started automatically by the SMS startup daemon.
ml d	The messages logging daemon provides message logging support for the platform and domains. This daemon is started automatically by the SMS startup daemon.
osd	The OpenBoot PROM server daemon provides software support for OpenBoot PROM process running on a domain through the mailbox that resides on the domain. When the domain OpenBoot PROM writes requests to the mailbox, the osd daemon executes those requests. On the main SC it is responsible for booting domains. This daemon is started automatically by the SMS startup daemon.
pcd	The platform configuration database daemon provides and manages controlled access to platform, domain, and system board configuration data. This daemon is started automatically by the SMS startup daemon.

TABLE 3-1 Daemons and Processes (*Continued*)

Daemon Name	Description
ssd	The SMS startup daemon starts, stops, and monitors all the key SMS daemons and servers.
tmd	The task management daemon provides task management services, such as scheduling for SMS. setkeyswitch and other daemons use tmd to schedule hardware power-on self test invocations. This daemon is started automatically by the SMS startup daemon.
wcapp	The optional wPCI application daemon implements Sun Fire Link clustering functionality and provides information to the external Sun Fire Link fabric manager server. It is not covered further in this manual. For more information on wcapp, refer to the <i>Sun Fire Link Fabric Administrator's Guide</i> .

Capacity on Demand Daemon

The capacity on demand daemon (codd (1M)) is a process that runs on the main system controller (SC).

This process does the following:

- Monitors the COD resources being used and verifies that the resources used are in agreement with the licenses in the COD license database.
- Provides information on installed licenses, resource use, and board status.
- Handles the requests to add or delete COD license keys.
- Configures headroom quantities and domain right-to-use (RTU) license reservations.

FIGURE 3-2 illustrates the CODD client server relationships to the SMS daemons and CLI commands.

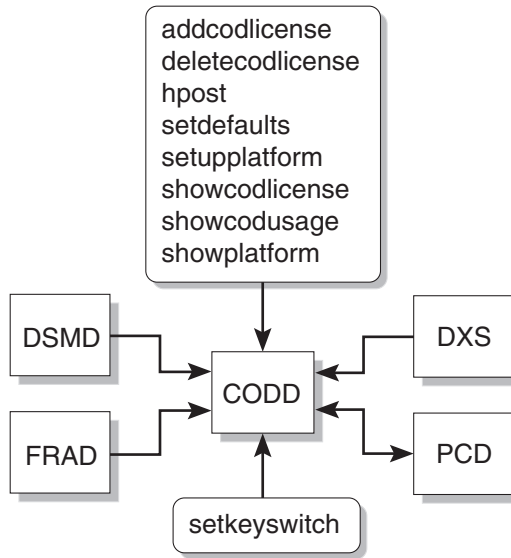

FIGURE 3-2 CODD Client Server relationships

Domain Configuration Agent

`dca(1M)` supports remote dynamic reconfiguration (DR) by enabling communication between applications and the domain configuration server (`dcs`) running on a Solaris 8 or Solaris 9 domain. One `dca` per domain runs on the SC. Each `dca` communicates with its `dcs` over the Management Network (MAN).

`ssd(1M)` starts `dca` when the domain is brought up. `ssd` restarts `dca` if it is killed while the domain is still running. `dca` is terminated when the domain is shut down.

`dca` is an SMS application that waits for dynamic reconfiguration requests. When a DR request arrives, `dca` creates a `dcs` session. Once a session is established, `dca` forwards the request to `dcs`. `dcs` attempts to honor the DR request and sends the results of the operation to the `dca`. Once the results have been sent, the session is ended. The remote DR operation is complete when `dca` returns the results of the DR operation.

FIGURE 3-3 illustrates the DCA client server relationships to the SMS daemons and CLIs.

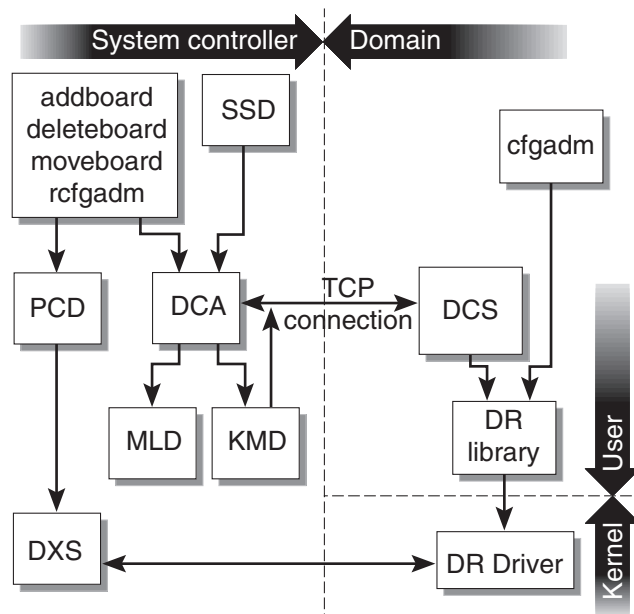

FIGURE 3-3 DCA Client Server Relationships

Domain Status Monitoring Daemon

`dsmd(1M)` monitors domain state signatures, CPU reset conditions and Solaris heartbeat for up to 18 domains on a Sun Fire 15K and up to nine on a Sun Fire 12K system. It also handles domain stop events related to hardware failure.

`dsmd` detects timeouts that can occur in reboot transition flow and panic transition flow, and handles various domain hung conditions.

`dsmd` notifies the domain X server (`dxs(1M)`) and Sun Management Center of all domain state changes and automatically recovers the domain based on the domain state signature, domain stop events, and automatic system recovery (ASR) Policy. ASR Policy consists of those procedures that restore the system to running all properly configured domains after one or more domains have been rendered inactive. This can be due to software or hardware failures or to unacceptable environmental conditions. For more information, see [“Automatic System Recovery \(ASR\)” on page 145](#) and [“Domain Stop Events” on page 214](#).

`dsmd` also passes automatic diagnosis (AD) information related to the domain stop to `efhd`.

FIGURE 3-4 illustrates DSMD client server relationships to the SMS daemons and CLIs.

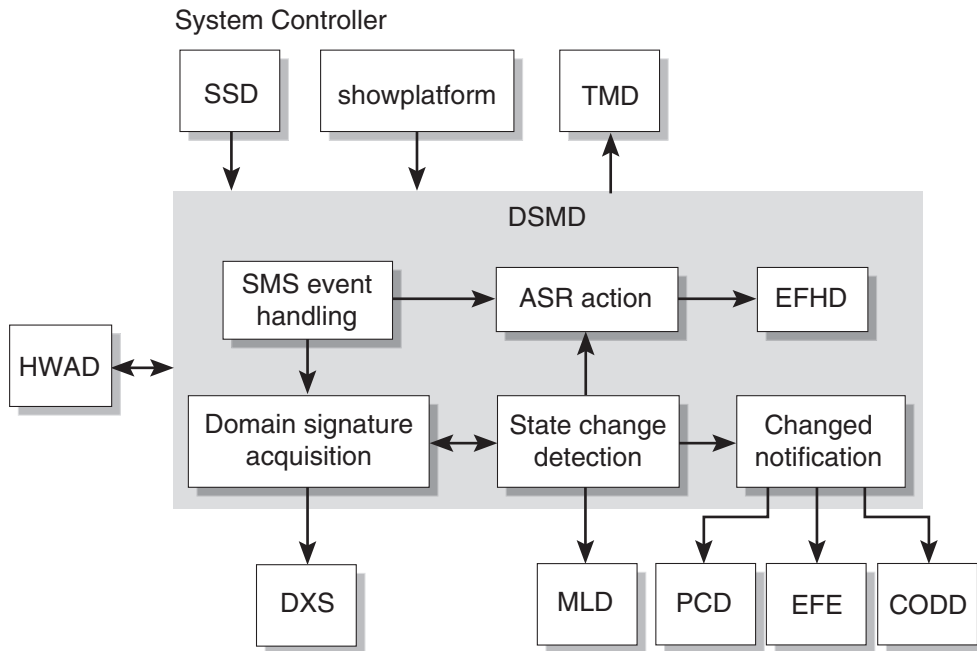

FIGURE 3-4 DSMD Client Server Relationships

Domain X Server

`dxs(1M)` provides software support for a running domain. This support includes virtual console functionality, dynamic reconfiguration support, and HPCI support. `dxs` handles domain driver requests and events. `dxs` provides an interface for getting and setting HPCI slot status. The slot status includes cassette presence, power, frequency, and health of the cassette. This interface makes it possible to power control HPCI cassettes for hot plug operations.

The virtual console functionality allows one or more users running the `console` program to access the domain's virtual console. `dxs` acts as a link between SMS console applications and the domain virtual console drivers.

A Sun Fire 15K system can support up to 18 different domains. A Sun Fire 12K system can support up to nine domains. Each domain may require software support from the SC, and `dxs` provides that support. The following domain-related projects require `dxs` support:

- DR
- HPCI
- Virtual console

There is one domain X server for each Sun Fire high-end system domain. `dxs` is started by `ssd` for every active domain, that is, a domain running OS software, and terminated when the domain is shut down.

FIGURE 3-9 illustrates DXS client server relationships to the SMS daemons.

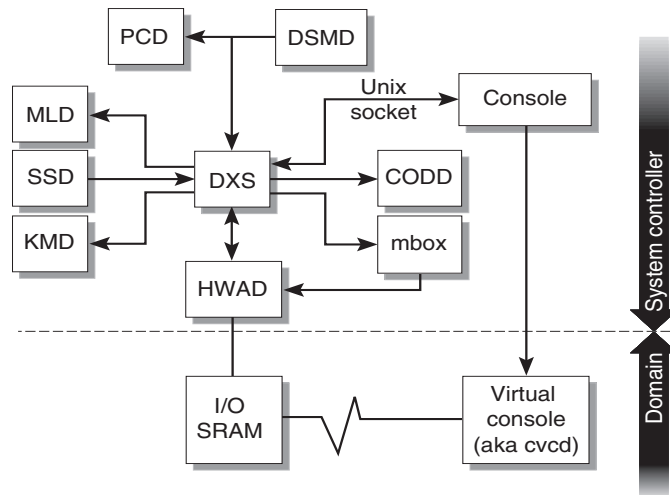

FIGURE 3-5 DXS Client Server Relationships

Error and Fault Handling Daemon

`efhd(1M)` does the following:

- Performs automatic error diagnosis based on the domain stop information passed by `dsmd(1M)`
- Updates the component health status for those components that have been associated with a fault, as determined by the diagnosis engine (SMS or the Solaris operating environment) or by POST.
- Passes the fault event to `erd(1M)` for error reporting.

FIGURE 3-6 illustrates EFHD client server relationships to the SMS daemons.

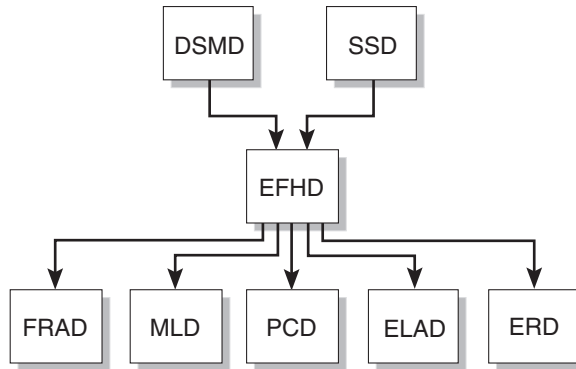

FIGURE 3-6 EFHD Client Server Relationships

Event Log Access Daemon

e1ad (1M) controls access to the SMS event log, which records fault and error events identified by the automatic diagnosis (AD) or POST diagnosis engines on a Sun Fire high-end system. e1ad also archives events when the event log fills.

[FIGURE 3-7](#) illustrates the ELAD client server relationships to the SMS daemons and CLI commands.

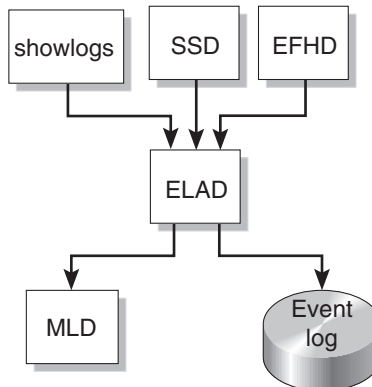

FIGURE 3-7 ELAD Client Server Relationships

Event Reporting Daemon

erd(1M) provides reporting services that deliver fault event text messages to the platform and domain logs, fault event information to Sun Management Center and SRS Net Connect, and email that contains fault event messages.

erd reads the email control file and the email template file each time email event notification occurs.

FIGURE 3-8 illustrates the ERD client server relationships to the SMS daemons.

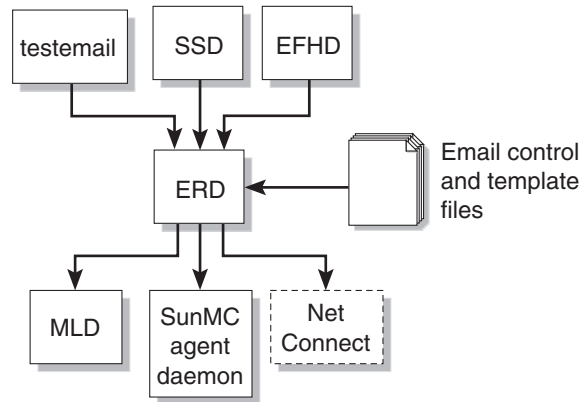

FIGURE 3-8 ERD Client Server Relationships

Environmental Status Monitoring Daemon

esmd(1M) monitors system cabinet environmental conditions, for example, voltage, temperature, fan tray, power supply and clock phasing. esmd logs abnormal conditions and takes action to protect the hardware, if necessary.

See “Environmental Events” on page 210 for more information on esmd.

FIGURE 3-9 illustrates ESMD client server relationships to the SMS daemons.

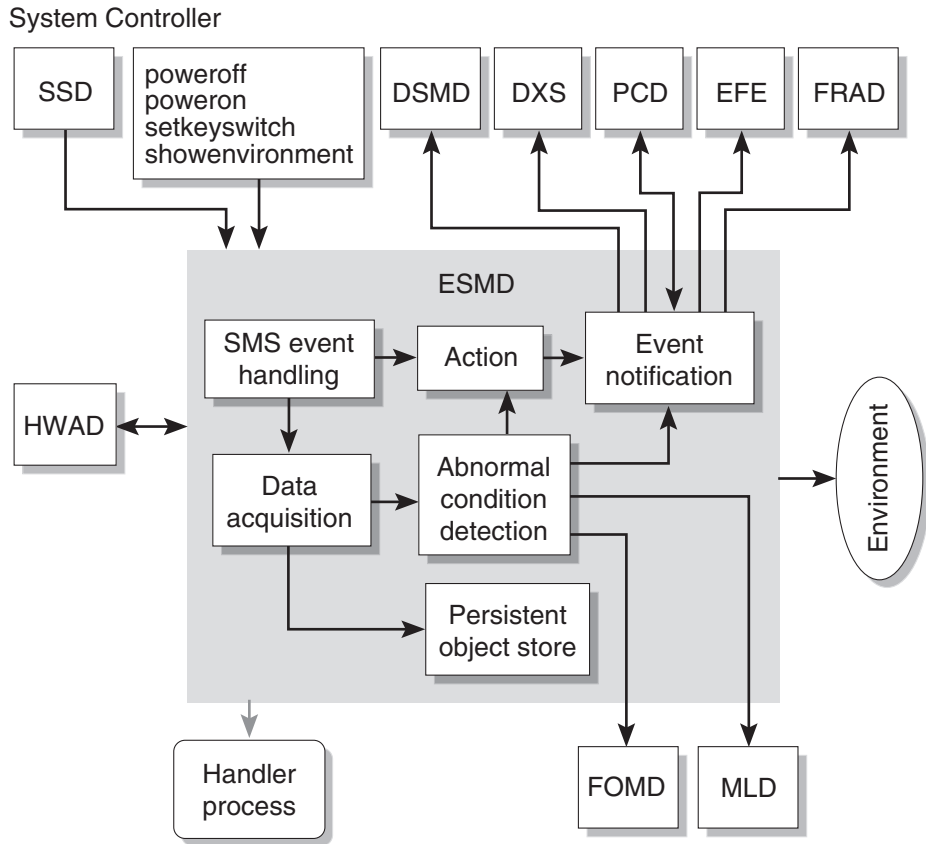

FIGURE 3-9 ESMD Client Server Relationships

Failover Management Daemon

`fomd(1M)` is the core of the SC failover mechanism. `fomd` detects faults on the local and remote SCs and takes the appropriate action (directing a failover or takeover). `fomd` tests and ensures that important configuration data is kept synchronized between both SCs. `fomd` runs on both the main and spare SCs.

For more information on `fomd` see [“SC Failover” on page 179](#).

[FIGURE 3-10](#) illustrates FOMD client server relationships to the SMS daemons.

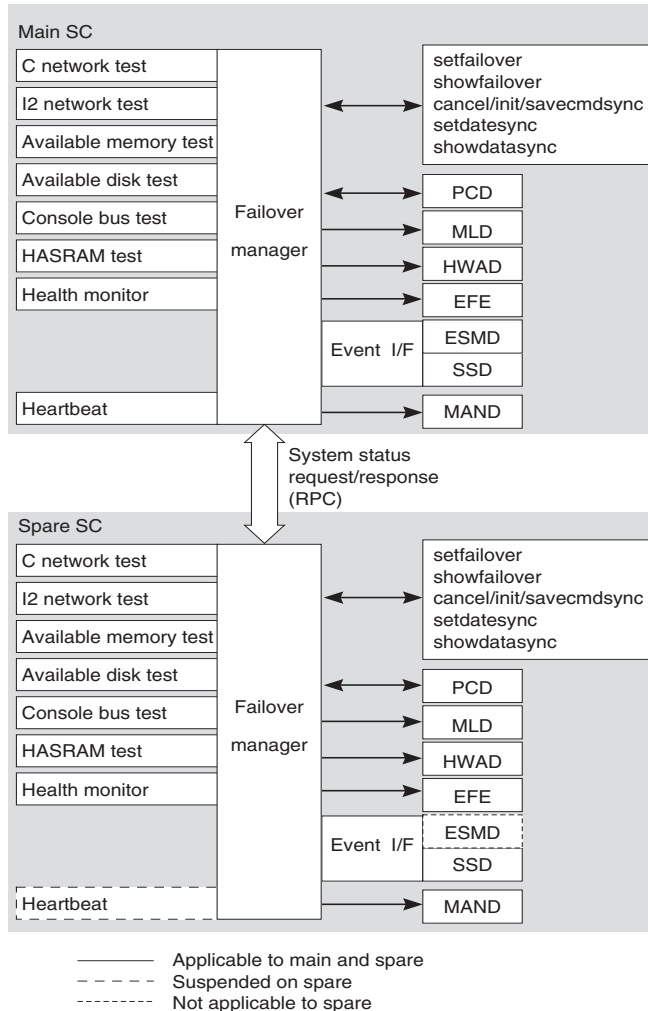

FIGURE 3-10 FOMD Client Server Relationships

FRU Access Daemon

`frad(1M)` is the field-replaceable unit (FRU) access daemon for SMS. `frad` provides controlled access to any serial electrically erasable programmable read-only memory (SEEPROM) within the Sun Fire high-end platform that is accessible by the SC. `frad`

supports dynamic FRUID which provides improved FRU data access using the Solaris platform information and control library daemon (PICLD). FRU identification is for Sun Service use only and transparent to the user.

`frad` is started by `ssd`.

FIGURE 3-11 illustrates FRAD client server relationships to the SMS daemons.

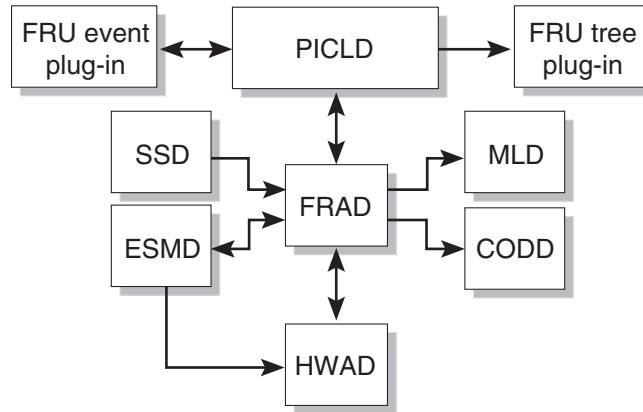

FIGURE 3-11 FRAD Client Server Relationships

Hardware Access Daemon

`hwad(1M)` provides hardware access to SMS daemons and a mechanism for all daemons exclusively to access, control, monitor, and configure the hardware.

`hwad` runs in either main or spare mode when it comes up. The failover daemon (`fomd(1M)`) determines which role `hwad` plays.

On both the main and spare, `hwad`:

- Opens all the drivers (`sbbc`, `echip`, `gchip`, and `conbus`) and uses `ioctl(2)` calls to interface with them.
- Configures the local system clock and sets the clock source for each board present in the system.
- Disables SC to SC interrupt.
- Disables DARB interrupts by clearing SBBC system interrupt enable register.
- Creates an `echip` interface, which waits for any interrupt coming from the Echip driver. At startup this is the SC heartbeat interrupt.

On the main SC, `hwad`:

- Reads the contents of the device presence register to identify the boards present in the system and makes them accessible to the clients.
- Takes control of I²C steering and initializes all board objects present in the machine.
- Checks that clocks are phase locked. If they are, `hwad` checks that all clock sources are pointing to the main SC. If the clocks are not phase locked, `hwad` does not change any clock sources and disables automatic clock switch.
- Initializes the DARB interrupt, enables DARB interrupt, and enables PCI interrupt generation. Disables clock failure interrupt in `gchip`, disables console bus error interrupt in `Echip`, disables power supply failure interrupt in `echip`.
- Initializes the interrupt handler for events and creates threads to service events for `mand`, `dsmd` and each `osd`.
- Creates the IOSRAM interfaces for 18 domains. This enables communication between the SC and the domain.

On the Spare SC `hwad`:

- Sets the spare SC clock to the main SC clock. Also sets the reference select to 0. Initializes SC to SC interrupt.

`hwad` directs communication to the IOSRAM (tunnel switch) for dynamic reconfiguration (DR).

`hwad` notifies `dsmd(1M)` if there is a `dstop` or `rstop`. It also notifies related SMS daemon(s) depending on the type of the `Mbox` interrupt that occurs.

`hwad` detects and logs console bus and JTAG errors.

Hardware access to a Sun Fire high-end system on the SC is done either by going through the PCI bus or console bus. Through the PCI bus you can access:

- SC BBC internal registers
- SC local JTAG
- Global I²C devices for clock and power control/status.

Through the Console bus you can access:

- Various ASICs internal registers
- Read/write chips
- Local I²C devices on various boards for temperature and chip level power control/status.

FIGURE 3-12 illustrates HWAD client server relationships to the SMS daemons and CLIs.

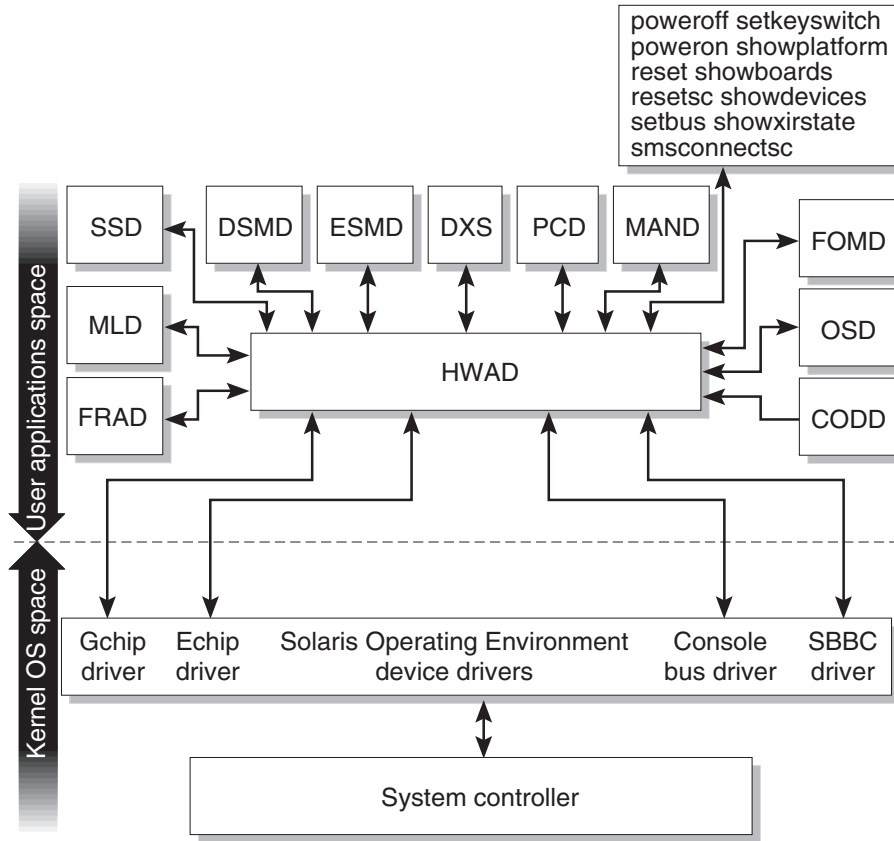

FIGURE 3-12 HWAD Client Server Relationships

Key Management Daemon

The key management daemon provides a mechanism for managing security for socket communications between the SC and the domains.

The current default configuration includes authentication policies for the `dca(1M)` and `dxs(1M)` clients on the SC, which connect to the `dcs(1M)` and `cvcd(1M)` servers on a domain.

`kmd(1M)` manages the IPsec security associations (SAs) needed to secure the communication between the SC and servers running on a domain.

`kmd` manages per-socket policies for connections initiated by clients on the SC to servers on a domain.

At system startup, `kmd` creates a domain interface for each domain that is active. An active domain has both a valid IOSRAM and is running the Solaris operating environment. Domain change events can trigger creation or removal of a domain `kmd` interface.

`kmd` manages shared policies for connections initiated by clients on the domain to servers on the SC. The `kmd` policy manager reads a configuration file and stores policies used to manage security associations. A request received by `kmd` is compared to the current set of policies to ensure that it is valid and to set various parameters for the request.

Static global policies are configured using `ipseccnf(1M)` and associated data file (`/etc/inet/ipseccinit.conf`). Global policies are used for connections initiated from the domains to the SC. Corresponding entries are made in the `kmd` configuration file. Shared security associations for domain to SC connections are created by `kmd` when the domain becomes active.

Note – In order to work properly, policies created by `ipseccnf` and `kmd` must match.

The `kmd` configuration file is used for both SC-to-domain and domain-to-SC initiated connections. The `kmd` configuration file resides in `/etc/opt/SUNWSMS/config/kmd_policy.conf`.

The format of the `kmd` configuration files is as follows:

```
dir:d_port:protocol:sa_type:aut_alg:encr_alg:domain:login
```

where:

<code>dir</code>	Identified using the <code>sctodom</code> or <code>domtosc</code> strings.
<code>d_port</code>	The destination port.
<code>protocol</code>	Identified using the <code>tcp</code> or <code>udp</code> strings.
<code>sa_type</code>	The security association type. Valid choices are the <code>ah</code> or <code>esp</code> strings.
<code>auth_alg</code>	The authentication algorithm. The authentication algorithm is identified using the <code>none</code> or <code>hmac-md5</code> strings or leaving the field blank.

encr_alg	The encryption algorithm. The encryption algorithm is identified using the none or des strings or leaving the field blank.
domain	The <i>domain_id</i> associated with the domain. Valid <i>domain_ids</i> are integers 0–17, space Using a space in the <i>domain_id</i> field defines a policy that applies to all domains. A policy for a specific domain overrides a policy applied to all domains.
login_name	The login name of the user affected by the policy. Currently this includes sms-dxs, sms-dca, and sms-ml.d.

For example:

```
# Copyright (c) 2002 by Sun Microsystems, Inc.
# All rights reserved.
#
# This is the policy configuration file for the SMS Key Management Daemon.
# The policies defined in this file control the desired security for socket
# communications between the system controller and domains.
#
# The policies defined in this file must match the policies defined on the
# corresponding domains. See /etc/inet/ipsecinit.conf on the Sun Fire high-end
# system domain.
# See also the ipsec(7P), ipsecconf(1M) and skmd(1M) man pages.
#
# The fields in the policies are a tuple of eight fields separated by the pipe
# '|' # character.
#
# <dir>|<d_port>|<protocol>|<sa_type>|<auth_alg>|<encr_alg>|<domain>|<login>|
#
# <dir>          --- direction to connect from. Values: sctodom, domtosc
# <d_port>       --- destination port
# <protocol>     --- protocol for the socket. Values: tcp, udp
# <sa_type>      --- security association type. Values: ah, esp
# <auth_alg>     --- authentication algorithm. Values: none, md5, sha1
# <encr_alg>     --- encryption algorithm. Values: none, des, 3des
# <domain>      --- domain id. Values: integers 0 - 17, space
#                A space for the domain id defines a policy which applies
#                to all domains. A policy for a specific domain overrides
#                a policy which applied to all domains.
# <login>       --- login name. Values: Any valid login name
#
# -----
sctodom|665|tcp|ah|md5|none| |sms-dca|
sctodom|442|tcp|ah|md5|none| |sms-dxs|
```

FIGURE 3-13 illustrates KMD client server relationships to the SMS daemons.

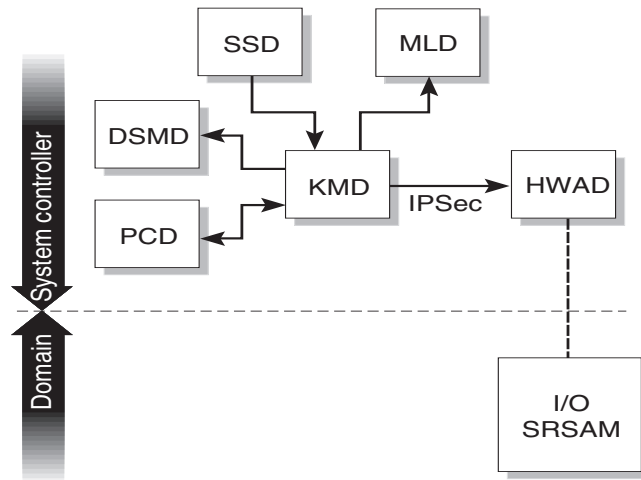

FIGURE 3-13 KMD Client Server Relationships

Management Network Daemon

mand(1M) supports the Management Network (MAN). See “[Management Network Services](#)” on page 165. By default, mand comes up in spare mode and switches to main when told to do so by the failover daemon (fomd(1M)). fomd determines which role mand plays.

At system startup, mand comes up in the role of spare and configures the SC-to-SC private network. This information is obtained from the file `/etc/opt/SUNWSMS/config/MAN.cf`, which is created by the `smsconfig(1M)` command. The failover daemon (fomd(1M)) directs mand to assume the role of main.

In the main role mand:

- Registers for domain change events from platform configuration database (pcd) to track changes in the domain active board list.
- Creates the mapping between domain_tag and IP address in the pcd,
- Initializes the scman(7d) driver with the current domain configuration.
- Registers for events from hwad to track active Ethernet information from the dman(7d) driver.
- Updates the scman driver and pcd, as appropriate.
- Registers for domain keyswitch events to communicate system startup MAN information to each domain when the domain is powered on (setkeyswitch on). This information includes Ethernet and MAN IP addressing, and active board list information used during the initial software installation on the domain.

FIGURE 3-14 illustrates MAND client server relationships to the SMS daemons.

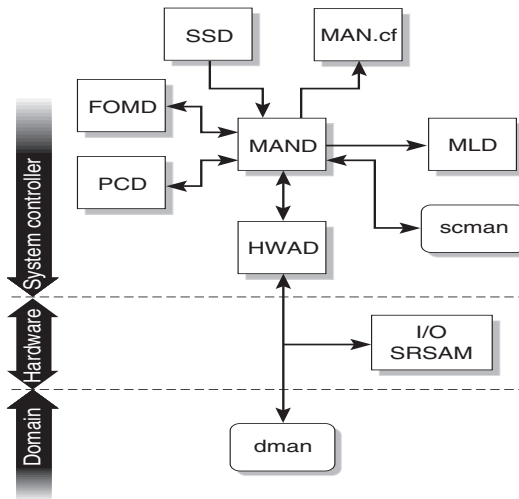

FIGURE 3-14 MAND Client Server Relationships

Message Logging Daemon

The message logging daemon, `mlD`, captures the output of all other SMS daemons and processes. `mlD` supports three configuration directives: File, Level, and Mode, in the `/var/opt/SUNWSMS/adm/.logger` file.

- **File**—Specifies the default output locations for the message files. The default is `msgdaemon` and should *not* be changed.
 - Platform messages are stored on the SC in `/var/opt/SUNWSMS/adm/platform/messages`
 - Domain messages are stored on the SC in `/var/opt/SUNWSMS/adm/domain_id/messages`
 - Domain console messages are stored on the SC in `/var/opt/SUNWSMS/adm/domain_id/console`
 - Domain syslog messages are stored on the SC in `/var/opt/SUNWSMS/adm/domain_id/syslog`.
- **Level**—Specifies the minimum level necessary for a message to be logged. The supported levels are NOTICE, WARNING, ERR, CRIT, ALERT, and EMERG. The default level is NOTICE.
- **Mode**—Specifies the verbosity of the messages. Two modes are available: `verbose` and `terse`. The default is `verbose`.

mld monitors the size of each of the message log files. For each message log type, mld keeps up to ten message files at a time, x.0 through x.9. For more information on log messages, see [“Message Logging” on page 199](#).

FIGURE 3-15 illustrates MLD client server relationships to the SMS daemons and CLIs.

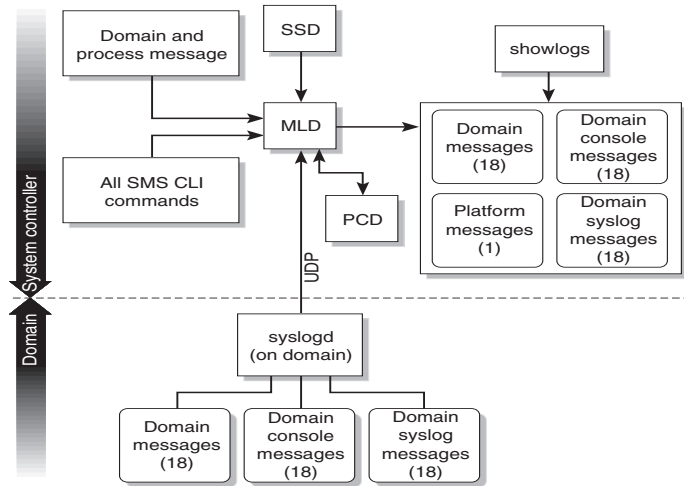

FIGURE 3-15 MLD Client Server Relationships

OpenBoot PROM Support Daemon

osd(1M) provides support to the OpenBoot PROM process running on a domain. osd and OpenBoot PROM communication is through a mailbox that resides on the domain. The osd daemon monitors the OpenBoot PROM mailbox. When the OpenBoot PROM writes requests to the mailbox, osd executes the requests accordingly.

osd runs at all times on the SC even if there are no domains configured. osd provides virtual TOD service, virtual NVRAM, and virtual REBOOTINFO for OpenBoot PROM and an interface to dsmd(1M) to facilitate auto-domain recovery. osd also provides an interface for the following commands: setobpparams(1M), showobpparams(1M), setdate(1M), and showdate(1M). See also [“SMS Configuration” on page 61](#).

osd is a trusted daemon in that it will not export any interface to other SMS processes. It exclusively reads and writes from and to all OpenBoot PROM mailboxes. There is one OpenBoot PROM mailbox for each domain.

osd has two main tasks; to maintain its current state of the domain configuration, and to monitor the OpenBoot PROM mailbox.

FIGURE 3-16 illustrates OSD client server relationships to the SMS daemons and CLIs.

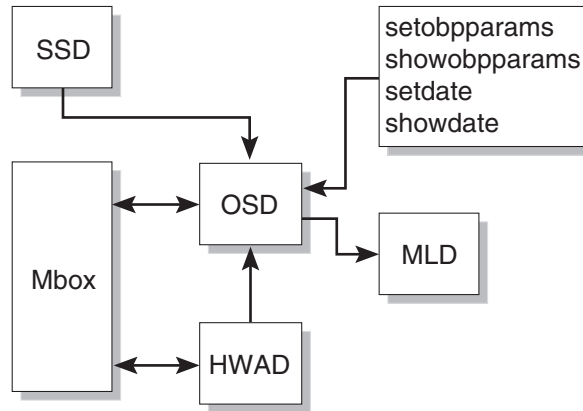

FIGURE 3-16 OSD Client Server Relationships

Platform Configuration Database Daemon

pcd(1M) is a Sun Fire high-end system management daemon that runs on the SC with primary responsibility for managing and providing controlled access to platform and domain configuration data.

pcd manages an array of information that describes the Sun Fire system configuration. In its physical form, the database information is a collection of flat files, each file appropriately identifiable by the information contained within it. All SMS applications that want to access the database information must go through pcd.

In addition to managing platform configuration data, pcd is responsible for platform configuration change notifications. When pertinent platform configuration changes occur within the system, the pcd sends out notification of the changes to clients who have registered to receive the notification.

FIGURE 3-17 illustrates PCD client server relationships to the SMS daemons and CLIs.

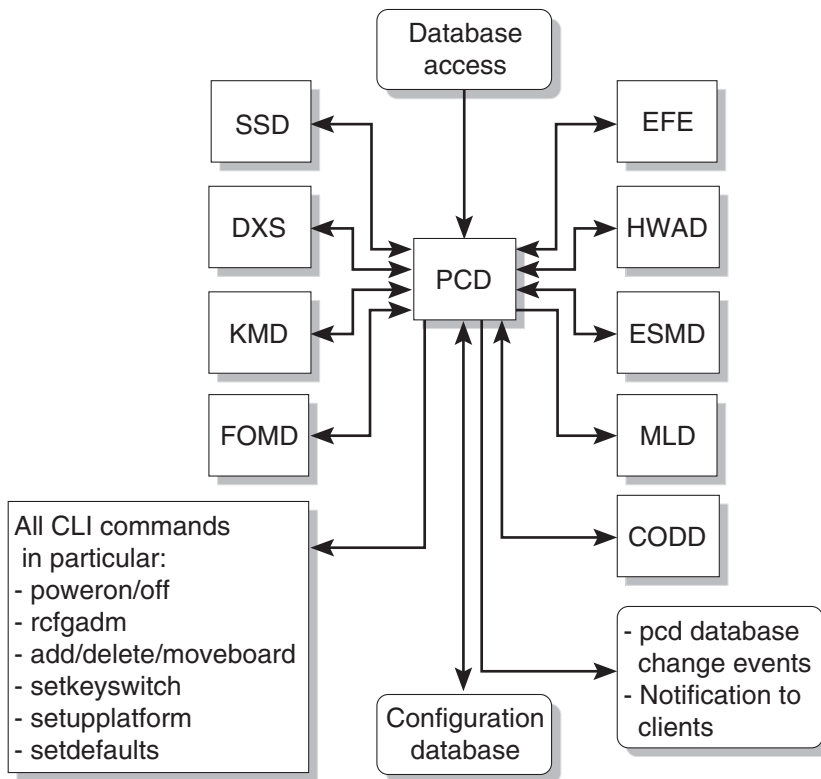

FIGURE 3-17 PCD Client Server Relationships

Platform Configuration

The following information uniquely identifies the platform:

- Platform type
- Platform name
- Chassis HostID

The Chassis HostID is used only by the COD feature to identify the platform for COD licensing purposes. The Chassis HostID is the centerplane serial number and is recorded internally within the system. To view the Chassis HostID, run the `showplatform -p cod` command.

- Chassis serial number

The chassis serial number identifies a Sun Fire high-end system and is used to identify the platform in messages and events. It is also used by service providers to correlate events and service actions to the correct system. The chassis serial

number is printed on a label located on the front of the system chassis, near the bottom center. Starting with the SMS 1.4 release, the chassis serial number is automatically recorded by Sun manufacturing on systems that ship with SMS 1.4 installed. To view the chassis serial number, run the `showplatform -p csn` command.

If you are upgrading to SMS 1.4 from an earlier SMS version, use the `setcsn(1M)` command to record the chassis serial number. For details on the `setcsn` command, refer to the command description in the *System Management Services (SMS) 1.4 Reference Manual*.

- Cacheable address slice map
- System clock frequency
- System clock type
- SC IP address
- SC0 to SC1 IP address
- SC1 to SC0 IP address
- SC to SC IP netmask
- COD instant access CPUs (headroom)

Domain Configuration

The following information is domain related:

- `domain_id`
- `domain_tag`
- OS version (currently not used)
- OS type (currently not used)
- Available component list
- Assigned board list
- Active board list
- Golden IOSRAM I/O board
- Virtual keyswitch setting for a domain
- Active Ethernet I/O board
- Domain creation time
- Domain dump state
- Domain bringup priority
- IP host address
- Host name
- Host netmask
- Host broadcast address
- Virtual OpenBoot PROM address
- Physical OpenBoot PROM address
- COD RTU license reservation

System Board Configuration

The following information is related to system boards:

- Expander position
- Slot position
- Board type
- Board state
- Domain Identifier assigned to board
- Available component list state
- Board test status
- Board test level
- Board memory clear state
- COD enabled flag

SMS Startup Daemon

`ssd(1M)` is responsible for starting and maintaining all SMS daemons and domain X servers.

`ssd` checks the environment for availability of certain files and the availability of the Sun Fire high-end system, sets environment variables, and then starts `esmd(1M)` on the main. `esmd` monitors environmental changes by polling the related hardware components. When an abnormal condition is detected, `esmd` handles it or generates an event so that the correspondent handlers take appropriate action and/or update their current status. Some of those handlers are: `dsmd`, `pcd` and Sun Management Center (if installed). The main objective of `ssd` is to ensure that the SMS daemons and servers are always up and running.

[FIGURE 3-18](#) illustrates SSD client server relationships to the SMS daemons.

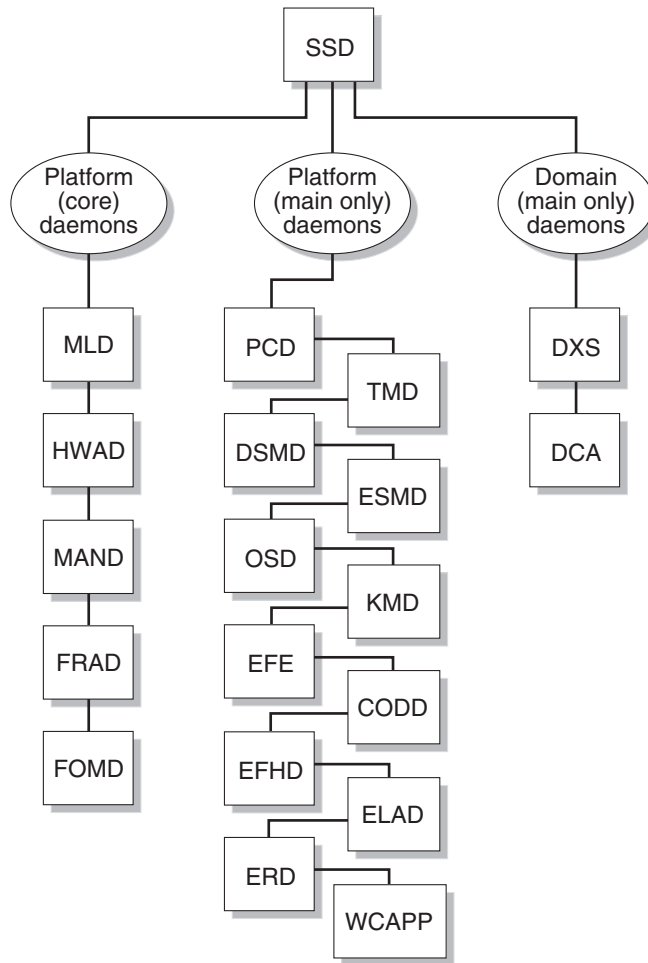

FIGURE 3-18 SSD Client Server Relationships

Scripts

`ssd` uses a configuration file, `ssd_start` to determine which components and in what order to start up the SMS software. This configuration file is located in the `/etc/opt/SUNWSMS/startup` directory.



Caution – This is a system configuration file. Mistakes in editing this file can render the system inoperable. `args` is the only field that should ever be edited in this script. Refer to the daemon man pages for specific options and pay particular attention to syntax.

`ssd_start` consists of entries in the following format:

name:args:nice:role:type:trigger:startup_timeout:shutdown_timeout:uid:start_order:stop_order

where:

<i>name</i>	The name of the program.
<i>args</i>	The valid program options or arguments. Refer to the daemon man pages for more information.
<i>nice</i>	Specifies a process priority tuning value. Do <i>not</i> adjust.
<i>role</i>	Specifies whether the daemon is platform or domain specific.
<i>type</i>	Specifies whether the program is a daemon or a server.
<i>trigger</i>	Specifies whether the program should be started automatically or upon event reception.
<i>startup_timeout</i>	The time in seconds <code>ssd</code> will wait for the program to startup.
<i>stop_timeout</i>	The time in seconds <code>ssd</code> will wait for the program to shutdown.
<i>uid</i>	The <i>user_id</i> the associated program will run under.
<i>start_order</i>	The order in which <code>ssd</code> will startup the daemons. Do <i>not</i> adjust. Changing the default values can result in the SMS daemons not working properly.
<i>stop_order</i>	The order in which <code>ssd</code> will shutdown the daemons. Do <i>not</i> adjust. Changing the default values can result in the SMS daemons not working properly.

Spare Mode

Each time `ssd` starts, it comes up in `spare` mode. Once `ssd` has started the platform core daemons running, it queries `fomd(1M)` for its role. If the `fomd` query returns with `spare`, `ssd` stays in this mode. If the `fomd` returns with `main`, then `ssd` transitions to `main` mode.

After this initial query phase, `ssd` only switches between modes through events received from the `fomd`.

When in `spare` mode, `ssd` starts and monitors all of the core platform role, auto trigger programs in the `ssd_start` file. Currently, this list is made up of the following programs.

- `mld`
- `hwad`
- `mand`
- `frad`
- `fomd`

If, while in `main` mode, `ssd` receives a `spare` event, then `ssd` shuts down all programs except the core platform role and auto trigger programs found in the `ssd_start` file.

Main Mode

`ssd` stays in `spare` mode until it receives a `main` event. At that time, `ssd` starts and monitors (in addition to the already running daemons) all of the platform role (main only) event trigger programs, in the `ssd_start` file. This list is made up of the following programs.

- `pcd`
- `tmd`
- `dsmd`
- `esmd`
- `osd`
- `kmd`
- `efe`
- `codd`
- `efhd`
- `elad`
- `erd`
- `wcapp`

Finally, after starting all the platform role, event trigger programs, `ssd` queries the `pcd` to determine which domains are active. For each of these domains, `ssd` starts all the domain role, event trigger programs found in the `ssd_start` file.

Domain-Specific Process Startup

`ssd` uses domain start and stop events from `pcd` as instructions for starting and stopping domain-specific servers.

Upon reception, `ssd` either starts or stops all of the domain role, event trigger programs (for the domain identified) found in the `ssd_start` file.

Monitoring and Restarts

Once `ssd` has started a process, it monitors the process and restarts in the event the process fails.

SMS Shutdown

In certain instances, such as SMS software upgrades, the SMS software needs to be shut down. `ssd` provides a mechanism to shut down itself and all SMS daemons and servers under its control.

`ssd` notifies all SMS software components under its control to shut down. After all the SMS software components have been shut down, `ssd` shuts itself down.

Task Management Daemon

`tmd(1M)` provides task management services such as scheduling for SMS. This reduces the number of conflicts that can arise during concurrent invocations of the hardware tests and configuration software.

Currently, the only service exported by `tmd` is the `hpost(1M)` scheduling service. In a Sun Fire high-end system, `hpost` is scheduled based on two factors.

- Restriction of `hpost`. When the platform first comes up and no domains have been configured, a single instance of `hpost` takes exclusive control of all expanders and configures the centerplane ASICs. All subsequent `hpost` invocations wait until this is complete before proceeding.

Only a single `hpost` invocation can act on any one expander at a time. For a Sun Fire high-end system configured without split expanders, this restriction does not prevent multiple `hpost` invocations from running. This restriction does come into play however, when the machine is configured with split expanders.

- System-wide `hpost` throttle limit. There is a limit to the number of concurrent `hpost` invocations that can run at a single time without saturating the system. The ability to throttle `hpost` invocations is available using the `-t` option in `ssd_startup`.



Caution – Changing the default value can adversely affect system functionality. Do not adjust this parameter unless instructed by a Sun service representative to do so.

FIGURE 3-19 illustrates TMD client server relationships to the SMS daemons.

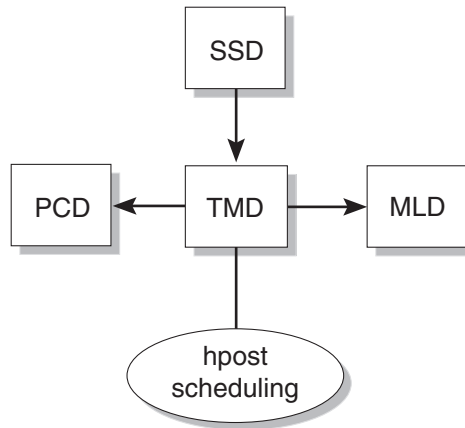

FIGURE 3-19 TMD Client Server Relationships

Environment Variables

Basic SMS environment defaults *must* be set in your configuration files to run SMS commands.

- PATH to include /opt/SUNWSMS/bin
- LD_LIBRARY_PATH to include /opt/SUNWSMS/lib
- MANPATH to include /opt/SUNWSMS/man

Setting other environment variables when you log in can save time. TABLE 3-2 suggests some useful SMS environment variables.

TABLE 3-2 Example Environment Variables

SMSSETC	The path to the <code>/etc/opt/SUNWSMS</code> directory containing miscellaneous SMS-related files.
SMSLOGGER	The path to the <code>/var/opt/SUNWSMS/adm</code> directory containing the configuration file for message logging, <code>.logger</code> .
SMSOPT	The path to the <code>/opt/SUNWSMS</code> directory containing the SMS package binaries, libraries, and object files; configuration and startup files.
SMSVAR	The path to the <code>/var/opt/SUNWSMS</code> directory containing platform and domain message and data files.

SMS Configuration

A *dynamic system domain* (DSD) is an independent environment, a subset of a server, that is capable of running a unique version of firmware and a unique version of the Solaris operating environment. Each domain is insulated from the other domains. Continued operation of a domain is not affected by any software failures in other domains nor by most hardware failures in any other domain.

The system controller (SC) supports commands that let you logically group system boards into *dynamic system domains*, or simply *domains*, which are able to run their own operating system and handle their own workload. Domains can be created and deleted without interrupting the operation of other domains. You can use domains for many purposes. For example, you can test a new operating system version or set up a development and testing environment in a domain. In this way, if problems occur, the rest of your system is not affected.

You can also configure several domains to support different departments, with one domain per department. You can temporarily reconfigure the system into one domain to run a large job over the weekend.

The Sun Fire 15K system allows up to 18 domains to be configured. The Sun Fire 12K system allows up to nine domains to be configured.

Domain configuration establishes mappings between the domains and the server's hardware components. Also included in domain configuration is the establishment of various system management parameters and policies for each domain. This chapter discusses all aspects of domain configuration functionality that the Sun Fire high-end system provides.

This chapter includes the following sections:

- [Domain Configuration Units](#)
- [Domain Configuration Requirements](#)
- [DCU Assignment](#)
- [Configuration for Platform Administrators](#)
- [Configuration for Domain Administrators](#)
- [Degraded Configuration Preferences](#)

Domain Configuration Units

A domain configuration unit (DCU) is a unit of hardware that can be assigned to a single domain. DCUs are the hardware components from which domains are constructed. DCUs that are not assigned to any domain are said to be in *no-domain*.

All DCUs are system boards and all system boards are DCUs. The Sun Fire high-end system DCUs are:

- CPU/memory board
- Sun Fire HsPCI I/O assembly (HPCI)
- Sun Fire HsPCI+ I/O assembly (HPCI+)
- Sun Fire MaxCPU board (MCPU)
- Sun Fire Link wPCI board (WPCI)

Sun Fire high-end system hardware requires the presence of at least one regular CPU/Memory board, plus at least one of the I/O board types in each configured domain. *csb*, *exb* boards, and the *SC* are *not* DCUs.

Note – MaxCPU boards do not contain memory. To set up a domain at least one regular CPU board is required.

Domain Configuration Requirements

You can create a domain out of any group of system boards, provided the following conditions are met:

- The boards are present and not in use in another domain.
- At least one board has a CPU and memory.
- At least one is an I/O board.
- At least one board has a network interface.
- The boards have sufficient memory to support an autonomous domain.
- The name you give the new domain is unique (as specified in the `addtag(1M)` command).
- You have an `idprom.image` file for the domain that was shipped to you by the factory. If your `idprom.image` file has been accidentally deleted or corrupted and you do not have a backup, contact your Sun field support representative.
- There must be at least one boot disk connected to one of the boards that will be grouped together into a domain. Alternatively, if a domain does not have its own disk, there must be at least one network interface so that you can boot the domain from the network.

DCU Assignment

The assignment of DCUs to a domain is the result of one of three logical operations acting on a DCU (system board):

- Adding the board (from *no-domain*) to a domain
- Removing the board from a domain (leaving the board in *no-domain*)
- Moving the board from one domain to another

Static Versus Dynamic Domain Configuration

Although there are logically three DCU assignment operations the underlying implementation is based upon four domain configuration operations:

- Adding a board to an inactive domain
- Removing a board from an inactive domain
- Adding a board to an active domain
- Removing a board from an active domain

The first two domain configuration operations apply to inactive domains, that is, to domains that are not running OS software. These operations are called static domain configuration operations. The latter two domain configuration operations apply to active domains, that is, those running OS software and are called dynamic domain configuration operations.

Dynamic domain configuration requires interaction with the domain's Solaris software to introduce or remove the DCU-resident resources such as CPUs, memory, or I/O devices from Solaris operating environment control. The Sun Fire high-end system dynamic reconfiguration (DR) project provides a capability called remote DR for an external agent, such as the SC, to request dynamic configuration services from a domain's Solaris environment.

The SC command user interfaces utilize remote DR as necessary to accomplish the requested tasks. Local automatic DR allows applications running on the domain to be aware of impending DR operations and to take action, as appropriate, to adjust to resource changes. This improves the likelihood of success of DR operations, particularly those which require active resources to be removed from domain use. For more information on DR, refer to the *System Management Services (SMS) 1.4 Dynamic Reconfiguration User Guide*.

When a domain is configured for local automatic DR, remote DR operations initiated from the SC benefit from the automation of DR operations for that domain. With local automatic DR capabilities available in Sun Fire domains, simple scripts can be constructed and placed in a `crontab(1)` file allowing simple platform reconfigurations to take place on a time schedule.

SMS allows you to add boards to or remove boards from an active (running) domain. Initiation of a remote DR operation on a domain requires administrative privilege for that domain. SMS grants the ability to initiate remote DR on a domain to individual administrators on a per-domain basis.

The remote DR interface is secure. Since invocation of DR operations on the domain itself requires superuser privilege, remote DR services are provided only to known, authenticated remote agents.

The user command interfaces that initiate DCU assignment operations are the same whether the affected domain(s) have local automatic DR capabilities or not.

SMS provides for the addition or removal of a board from an inactive domain, such as, static domain configuration using `addboard`, `deleteboard`, and `moveboard`. For more information, refer to the *System Management Services (SMS) 1.4 Dynamic Reconfiguration User Guide*.

Global Automatic Dynamic Reconfiguration

Remote DR and local automatic DR functions are building blocks for a feature called global automatic DR. Global automatic DR introduces a framework that can be used to automatically redistribute the system board resources on a Sun Fire system. This redistribution can be based upon factors such as production schedule, domain resource utilizations, domain functional priorities, and so on. Global automatic DR accepts input from customers describing their Sun Fire resource utilization policies and then uses those policies to automatically marshal the Sun Fire high-end system resources to produce the most effective utilization. For more information on DR, refer to the *System Management Services (SMS) 1.4 Dynamic Reconfiguration User Guide*.

Configuration for Platform Administrators

This section briefly describes the configuration services available to the platform administrator.

Available Component List

Each domain (A-R) defaults to having a 0-board list of boards that are available to an administrator or configurator to assign to their respective domain(s). Boards can be added to the available component list of a domain by a platform administrator using the `setupplatform(1M)` command. Updating an available component list requires `pcd` to perform the following tasks.

- Update the domain configuration available component list.
- Update the available component list state for each board to show the domain to which it is now available.
- Notify `dxs` of boards added to their respective domain's available component list.
- `dxs` notifies the running domain of the arrival of an available board.

▼ To Set Up the Available Component List

`setupplatform` sets up the available component list for domains. If a *domain_id* or *domain_tag* is specified, a list of boards must be specified. If no value is specified for a parameter, it will retain its current value.

1. **In an SC window, log in as a platform administrator.**

2. Type:

```
sc0:sms-user:> setupplatform -d domain_indicator -a location
```

where:

- a** Adds the slot to the available component list for the specified domain.
- d domain_indicator** Specifies the domain using:
- domain_id* - ID for a domain. Valid *domain_ids* are A-R and are not case sensitive.
- domain_tag* - Name assigned to a domain using `addtag(1M)`.
- location* The board (DCU) location.

The following *location* forms are accepted:

Valid form for Sun Fire 15K	Valid form for Sun Fire 12K
SB(0...17)	SB(0...8)
IO(0...17)	IO(0...8)

The following is an example of making boards at SB0, IO1, and IO2 available to domain A:

```
sc0:sms-user:> setupplatform -d A -a SB0 IO1 IO2
```

At this point the platform administrator can `assign` the board to domain A using the `addboard(1M)` command or leave that up to the domain administrator.

A platform administrator has privileges for only the `-c assign` option of the `addboard` command. All other board configuration requires domain privileges. For more information refer to the `addboard` man page.

Configuring Domains

▼ To Name or Change Domain Names From the Command Line

You do not need to create domains on the Sun Fire high-end system. Eighteen domains have already been established (domains A–R, case insensitive). These domain designations are customizable. This section describes how to uniquely name domains.

Note – Before proceeding, see [“Domain Configuration Requirements” on page 62](#). If the system configuration must be changed to meet any of these requirements, call your service provider.

1. Log in to the SC.

2. Type:

```
sc0:sms-user:> addtag -d domain_indicator new_tag
```

where:

<i>-d domain_indicator</i>	Specifies the domain using: <i>domain_id</i> - ID for a domain. Valid <i>domain_ids</i> are A–R and are not case sensitive. <i>domain_tag</i> - Name assigned to a domain using <code>addtag(1M)</code> .
<i>new_tag</i>	The new name you want to give to the domain. It must be unique among all domains controlled by the SC.

Naming a domain is optional.

The following is an example of naming Domain A to `dmnA`:

```
sc0:sms-user:> addtag -d A dmnA
```

▼ To Add Boards to a Domain From the Command Line

1. Log in to the SC.

Note – Platform administrators are restricted to using the `-c assign` option and only for `available` not `active` boards.

The system board must be in the `available` state to the domain to which it is being added. Use the `showboards (1M)` command to determine a board's state.

2. Type:

```
sc0:sms-user:> addboard -d domain_indicator -c assign location...
```

where:

- d domain_indicator** Specifies the domain using:
- domain_id* - ID for a domain. Valid *domain_ids* are A-R and are not case sensitive.
- domain_tag* - Name assigned to a domain using `addtag(1M)`.
- c assign** Specifies the transition of the board from the current configuration state to the `assigned` state.
- location* The board (DCU) location. Multiple locations are permitted.

The following *location* forms are accepted:

Valid form for Sun Fire 15K	Valid form for Sun Fire 12K
SB(0...17)	SB(0...8)
IO(0...17)	IO(0...8)

For example:

```
sc0:sms-user:> addboard -d C -c assign SB0 IO1 SB1 IO2
```

SB0, IO1, SB1 and IO2 have now gone from being `available` to domain C to being `assigned` to it.

`addboard` performs tasks synchronously and does not return control to the user until the command is complete. If the command fails the board does not return to its original state. A `dxs` or `dca` error is logged to the domain and `pcd` reports an error to the platform log file. If the error is recoverable you can retry the command. If it is *unrecoverable*, you will need to reboot the domain in order to use that board.

▼ To Delete Boards From a Domain From the Command Line

Note – Platform administrators are restricted to using the `-c unassign` option and only for assigned not active boards.

1. Log in to the SC.

The system board must be in the assigned state to the domain from which it is being deleted. Use the `showboards (1M)` command to determine a board's state.

2. Type:

```
sc0:sms-user:> deleteboard -c unassign location...
```

where:

<code>-c unassign</code>	Specifies the transition of the board from the current configuration state to a new unassigned state.
<code>location</code>	The board (DCU) location. Multiple locations are permitted.

The following *location* forms are accepted:

Valid form for Sun Fire 15K	Valid form for Sun Fire 12K
SB(0...17)	SB(0...8)
IO(0...17)	IO(0...8)

For example:

```
sc0:sms-user:> deleteboard -c unassign SB0
```

SB0 has now gone from being assigned to the domain to being available to it.

If `deleteboard` fails, the board does not return to its original state. A `dxs` or `dca` error is logged to the domain and `pcd` reports an error to the platform log file. If the error is recoverable, you can retry the command. If it is *unrecoverable*, you need to reboot the domain in order to use that board.

▼ To Move Boards Between Domains From the Command Line

Note – Platform administrators are restricted to the `-c assign` option and only for assigned not active boards.

1. Log in to the SC.

The system board must be in the assigned state to the domain from which it is being deleted. Use the `showboards (1M)` command to determine a board's state.

2. Type:

```
sc0:sms-user:> moveboard -d domain_indicator -c assign location
```

where:

`-d domain_indicator` Specifies the domain using:

domain_id - ID for a domain. Valid *domain_ids* are A–R and are not case sensitive.

domain_tag - Name assigned to a domain using `addtag(1M)`.

`-c assign` Specifies the transition of the board from the current configuration state to an assigned state.

location The board (DCU) location.

The following *location* forms are accepted:

Valid form for Sun Fire 15K	Valid form for Sun Fire 12K
SB(0...17)	SB(0...8)
IO(0...17)	IO(0...8)

`moveboard` performs tasks synchronously and does not return control to the user until the command is complete. You can only specify one *location* when using `moveboard`.

For example:

```
sc0:sms-user:> moveboard -d C -c assign SB0
```

SB0 has been moved from its previous domain and assigned to domain C.

If `moveboard` fails, the board does not return to its original state. A `dxs` or `dca` error is logged to the domain and `pcd` reports an error to the platform log file. If the error is recoverable, you can retry the command. If it is *unrecoverable*, you need to reboot the domain the board was in when the error occurred, in order to use that board.

▼ To Set Domain Defaults

In the event you wish to remove all instances of a previously active domain, SMS provides the `setdefaults(1M)` command.

1. Log in to the SC.

Platform administrators can set domain defaults for all domains, but only one domain at a time. The domain must *not* be active and `setkeyswitch` must be set to off.

`setdefaults` removes *all* pcd entries except network information and log files. This includes removing the NVRAM and boot parameter data.

By default, you are asked whether you want to remove the NVRAM and boot parameter data. If you say respond no, the data is preserved. If you use the `-p` option you are not prompted and the data is automatically preserved.

2. Type:

```
sc0:sms-user:> setdefaults -d domain_indicator [-p]
```

where:

<code>-d domain_indicator</code>	Specifies the domain using: <i>domain_id</i> - ID for a domain. Valid <i>domain_ids</i> are A-R and are not case sensitive. <i>domain_tag</i> - Name assigned to a domain using <code>addtag(1M)</code> .
<code>-p</code>	Preserves the NVRAM and boot parameter data without a prompt.

For more information on `setdefaults` refer to the `setdefaults` man page or the *System Management Services (SMS) 1.4 Reference Manual*.

▼ To Obtain Board Status

1. Log in to the SC.

Platform administrators can obtain board status for all domains.

2. Type:

```
sc0:sms-user:> showboards [-d domain_id] [-d domain_tag]
```

The board status is displayed.

The following partial example, for the Sun Fire 15K system, shows the board information for a user with platform administrator privileges. All domains are visible. On a Sun Fire 12K system, nine domains would be shown.

```
sc0:sms-user:> showboards
```

Location	Pwr	Type	Board Status	Test Status	Domain
----	---	----	-----	-----	-----
SB0	On	CPU	Active	Passed	domainC
SB1	On	CPU	Active	Passed	A
SB2	On	CPU	Active	Passed	A
SB3	On	CPU	Active	Passed	engB
SB4	On	CPU	Active	Passed	engB
SB5	On	CPU	Active	Passed	engB
SB6	On	CPU	Active	Passed	A
SB7	On	CPU	Active	Passed	domainC
SB8	Off	CPU	Available	Unknown	Isolated
SB9	On	CPU	Active	Passed	dmnJ
SB10	Off	CPU	Available	Unknown	Isolated
SB11	Off	CPU	Available	Unknown	Isolated
SB12	Off	CPU	Assigned	Unknown	engB
SB13	-	Empty Slot	Available	-	Isolated
SB14	Off	CPU	Assigned	Failed	domainC
SB15	On	CPU	Active	Passed	P
SB16	On	CPU	Active	Passed	domainC
SB17	-	Empty Slot	Assigned	-	dmnR
IO0	-	Empty Slot	Available	-	Isolated
IO1	On	HPCI	Active	Passed	A
IO2	On	MCPU	Active	Passed	engB
IO3	On	MCPU	Active	Passed	domainC
IO4	On	HPCI+	Available	Degraded	domainC
IO5	Off	HPCI+	Assigned	Unknown	engB
IO6	On	HPCI	Active	Passed	A
IO7	On	HPCI	Active	Passed	dmnJ
IO8	On	WPCI	Active	Passed	Q
IO9	On	HPCI+	Assigned	iPOST	dmnJ
IO10	Off	HPCI	Assigned	Unknown	engB
IO11	Off	HPCI	Assigned	Failed	engB
IO12	Off	HPCI	Assigned	Unknown	engB
IO13	-	Empty Slot	Available	-	Isolated
IO14	Off	HPCI+	Available	Unknown	Isolated
IO15	On	HPCI	Active	Passed	P
IO16	On	HPCI	Active	Passed	Q
IO17	-	Empty Slot	Assigned	-	dmnR

▼ To Obtain Domain Status

1. Log in to the SC.

Platform administrators can obtain domain status for all domains.

2. Type:

```
sc0:sms-user:> showplatform -d domain_indicator
```

where:

`-d domain_indicator` Specifies the domain using:

domain_id - ID for a domain. Valid *domain_ids* are A-R and are not case sensitive.

domain_tag - Name assigned to a domain using `addtag(1M)`.

The status listing is displayed.

The following partial example, for the Sun Fire 15K system, shows the domain information for a user with platform administrator privileges. All domains are visible. On a Sun Fire 12K system, nine domains would be shown.

```
sc0:sms-user:> showplatform
...
Domain configurations:
=====
Domain ID Domain Tag      Solaris Nodename   Domain Status
A          newA          sun15-b0           Powered Off
B          engB          sun15-b1           Keyswitch Standby
C          domainC       sun15-b2           Running OBP
D          eng1          sun15-b3           Loading Solaris
E          -             sun15-b4           Running Solaris
F          domainF       sun15-b5           Running Solaris
G          dmng          sun15-b6           Running Solaris
H          -             sun15-b7           Solaris Quiesced
I          -             sun15-b8           Powered Off
J          dmngJ         sun15-b9           Powered Off
K          -             sun15-b10          Booting Solaris
L          -             sun15-b11          Powered Off
M          -             sun15-b12          Powered Off
N          -             sun15-b13          Keyswitch Standby
O          -             sun15-b14          Powered Off
P          -             sun15-b15          Running Solaris
Q          -             sun15-b16          Running Solaris
R          dmngR         sun15-b17          Running Solaris
```

Virtual Time of Day

The Solaris environment uses the functions provided by a hardware time of day (TOD) chip to support Solaris system date/time. Typically Solaris software reads the current system date/time at boot using a get TOD service. From that point forward, Solaris software either uses a high resolution hardware timer to represent current date/time or, if configured, uses Network Time Protocol (NTP) to synchronize current system date/time to a (presumably more accurate) time source.

The SC is the only computer on the platform that has a realtime clock. The virtual TOD for domains is stored as an offset from that realtime clock value. Each domain can be configured to use NTP services instead of `setdate(1M)` to manage the running system date/time. For more information on NTP, see [“Configuring NTP” on page 78](#) or refer to the `xntpd(1M)` man page in the *man Pages(1M): System Administration Commands* section of the Solaris 9 Reference Manual Collection.

Note – NTP is a separate package that must be installed and configured on the domain in order to function as described. Use `setdate` on the domain prior to installing NTP.

However system date/time is managed while Solaris software is running, an attempt is made to keep the boot-time TOD value accurate by setting the TOD when variance is detected between the current TOD value and the current system date/time.

Since the Sun Fire high-end system hardware provides no physical TOD chip for Sun Fire domains, SMS provides the time-of-day services required by the Solaris environment for each domain. Each domain is supplied with a TOD service that is logically separate from that provided to any other domain. This difference allows system date/time management on a Sun Fire high-end system domain to be as flexible as that provided by standalone servers. In the unlikely event that a domain needs to be set up to run at a time other than real world time, the Sun Fire high-end system TOD service allows that domain to be configured without affecting the TOD values supplied to other domains running real world time.

Time settings are implemented using `setdate(1M)`. You must have platform administrator privileges in order to run `setdate`. See [“All Privileges” on page 23](#) for more information.

Setting the Date and Time

`setdate(1M)` allows the SC platform administrator to set the system controller date and time values. After setting the date and time, `setdate(1M)` displays the current date and time for the user.

▼ To Set the Date on the SC

1. Log in to the SC.
2. Type:

```
sc0:sms-user:> setdate 021210302000.00  
System Controller: Tue Feb 12 10:30 2002 US/Pacific
```

Optionally, `setdate(1M)` can set a domain TOD. The domain's keyswitch must be in the `off` or `standby` position. You must have platform administrator privileges to run this command on the domain.

▼ To Set the Date for Domain eng2

1. Log in to the SC.
2. Type:

```
sc0:sms-user:> setdate -d eng2 021210302000.00  
Domain eng2: Tue Feb 12 10:30 2002 US/Pacific
```

`showdate(1M)` displays the current SC date and time.

▼ To Display the Date on the SC

1. Log in to the SC.
2. Type:

```
sc0:sms-user:> showdate  
System Controller: Tue Feb 12 10:30 2002 US/Pacific
```

Optionally, `showdate(1M)` can display the date and time for a specified domain. Superuser or any member of a platform or domain group can run `showdate`.

▼ To Display the Date on Domain eng2

1. Log in to the SC.

2. Type:

```
sc0:sms-user:> showdate -d eng2
Domain eng2: Tue Feb 12 10:30 2002 US/Pacific
```

Configuring NTP

The NTP daemon, `xntpd(1M)` for the Solaris 9 operating environment, provides a mechanism for keeping the time settings synchronized between the SC and the domains. The OpenBoot PROM obtains the time from the SC when the domain is booted, and NTP keeps the time synchronized on the domain from that point on.

NTP configuration is based on information provided by the system administrator.

The NTP packages are compiled with support for a local reference clock. This means that your system can poll itself for the time instead of polling another system or network clock. The poll is done through the network loopback interface. The numbers in the IP address are 127.127.1.0. This section describes how to set the time on the SC using `setdate`, and then to set up the SC to use its own internal time-of-day clock as the reference clock in the `ntp.conf` file.

NTP can also keep track of the drift (difference) between the SC clock and the domain clock. NTP corrects the domain clock if it loses contact with the SC clock, provided that you have a drift file declaration in the `ntp.conf` file. The drift file declaration specifies to the NTP daemon the name of the file that stores the error in the clock frequency computed by the daemon. See the following procedure for an example of the drift file declaration in an `ntp.conf` file.

If the `ntp.conf` file does not exist, create it as described below. You must have an `ntp.conf` file on both the SC and the domains.

▼ To Create the `ntp.conf` File

1. Log in to the main SC as superuser.
2. Change to the `/etc/inet` directory and copy the NTP *server* file to the NTP configuration file:

```
sc0:# cd /etc/inet
sc0:# cp ntp.server ntp.conf
```

3. Using a text editor, edit the `/etc/inet/ntp.conf` file created in the previous step.

The `ntp.conf` file for the Solaris 9 operating environment is located in `/etc/inet`.

The following is an example of server lines in the `ntp.conf` file on the main SC, to synchronize clocks.

```
server 127.127.1.0
fudge 127.127.1.0 stratum 13
driftfile /var/ntp/ntp.drift
statsdir /var/ntp/ntpstats/
filegen peerstats file peerstats type day enable
filegen loopstats file loopstats type day enable
filegen clockstats file clockstats type day enable
```

4. Save the file and exit.

5. Stop and restart the NTP daemon:

```
sc0:# /etc/init.d/xntpd stop
sc0:# /etc/init.d/xntpd start
```

6. Log in to the spare SC as superuser.

7. Change to the `/etc/inet` directory and copy the NTP *server* file to the NTP configuration file:

```
sc1:# cd /etc/inet
sc1:# cp ntp.server ntp.conf
```

8. Using a text editor, edit the `/etc/inet/ntp.conf` file created in the previous step.

The `ntp.conf` file for the Solaris 9 operating environment is located in `/etc/inet`.

The following is an example of server lines in the `ntp.conf` file on the spare SC, to synchronize clocks.

```
server 127.127.1.0
fudge 127.127.1.0 stratum 13
driftfile /var/ntp/ntp.drift
statsdir /var/ntp/ntpstats/
filegen peerstats file peerstats type day enable
filegen loopstats file loopstats type day enable
filegen clockstats file clockstats type day enable
```

9. Stop and restart the NTP daemon:

```
sc1:# /etc/init.d/xntpd stop
sc1:# /etc/init.d/xntpd start
```

10. Log in to each domain as superuser.

11. Change to the `/etc/inet` directory and copy the NTP *client* file to the NTP configuration file:

```
domain_id:# cd /etc/inet
domain_id:# cp ntp.client ntp.conf
```

12. Using a text editor, edit the `/etc/inet/ntp.conf` file created in the previous step.

The `ntp.conf` file for the Solaris 9 operating environment is located in `/etc/inet`.

For the Solaris 9 operating environment, you can add lines similar to the following to the `/etc/inet/ntp.conf` on the domains:

```
server main_sc_hostname prefer
server spare_sc_hostname
```

13. Save the file and exit.

14. Change to the initialization directory, and stop and restart the NTP daemon on the domain:

```
domain_id:# /etc/init.d/xntpd stop
domain_id:# /etc/init.d/xntpd start
```

NTP is now installed and running on your domain. Repeat [Step 10](#) through [Step 14](#) for each domain.

For more information on the NTP daemon, refer to the `xntpd(1M)` man page in the *man Pages(1M): System Administration Commands* section of the Solaris 9 Reference Manual Collection.

Virtual ID PROM

Each configurable domain has a virtual ID PROM that contains identifying information about the domain such as hostID and domain Ethernet address. The hostID is unique among all domains on the same platform. The Ethernet address is world unique.

Sun Fire high-end system management software provides a virtual ID PROM for each configurable domain containing identifying information that can be read, but not written, from the domain. The information provided meets the requirements of the Solaris environment.

Flashupdate Command

SMS provides the `flashupdate(1M)` command to update the Flash PROM in the system controller (SC), and the Flash PROMs in a domain's CPU and MaxCPU boards after SMS software upgrades or applicable patch installation. `flashupdate` displays both the current Flash PROM and the flash image file information prior to any updates.

Note – Once you have updated the SC FPRM(s) you must reset the SC using the `reset-all` command at the OpenBoot PROM (ok) prompt. No CLIs should be executed on a system board while `flashupdate` is running on that board. Wait until `flashupdate` completes before running any SMS commands involving that system board.

For more information and examples, refer to the `flashupdate` man page.

Configuration for Domain Administrators

This section briefly goes over the configuration services available to the domain administrator.

Configuring Domains

The domain administrator has been given far more capability with regard to the `addboard`, `deleteboard`, and `moveboard` commands.

▼ To Add Boards to a Domain From the Command Line

1. **Log in to the SC as a domain administrator for that domain.**

Note – In order for the domain administrator to add a board to a domain, that board must appear in the domain available component list.

The system board must be in the available or assigned state to the domain to which it is being added. Use the `showboards (IM)` command to determine a board's state.

2. Type:

```
sc0:sms-user:> addboard -d domain_indicator -c function location
```

where:

- d *domain_indicator* Specifies the domain using:
- domain_id* - ID for a domain. Valid *domain_ids* are A-R and are not case sensitive.
- domain_tag* - Name assigned to a domain using addtag(1M).
- c *function* Specifies the transition of the board from the current configuration state to a new configuration state.
- location* The board (DCU) location.

Configuration states are:

- assign Assigns the board to the logical domain. The board belongs to the domain but is not active.
- connect Transitions an assigned board to the connected/unconfigured state. This is an intermediate state and has no standalone implementation.
- configure Transitions an assigned board to the connected/configured state. The hardware resources on the board can be used by Solaris software.

If the *-c function* option is not specified, the default expected configuration state is *configure*. For more detailed information on the configuration states refer to the *addboard(1M)* manpage.

Multiple locations are accepted.

The following *location* forms are accepted:

Valid form for Sun Fire 15K	Valid form for Sun Fire 12K
SB(0...17)	SB(0...8)
IO(0...17)	IO(0...8)

For example:

```
sc0:sms-user:> addboard -d C -c assign SB0 IO1 SB1 IO2
```

SB0, IO1, SB1 and IO2 have now gone from being available to domain C to being assigned to it.

`addboard` performs tasks synchronously and does not return control to the user until the command is complete. If the board is not powered on or tested, specify the `-c connect|configure` option, then the command will power on the board and test it.

If `addboard` fails, the board does not return to its original state. A `dxs` or `dca` error is logged to the domain and `pcd` reports an error to the platform log file. If the error is recoverable, you can retry the command. If it is *unrecoverable*, you need to reboot the domain in order to use that board.

▼ To Delete Boards From a Domain From the Command Line

1. Log in to the SC as a domain administrator for that domain.

The system board must be in the assigned or active state to the domain from which it is being deleted. Use the `showboards (1M)` command to determine a board's state.

2. Type:

```
sc0:sms-user:> deleteboard -c function location
```

where:

-c function Specifies the transition of the board from the current configuration state to a new configuration state.

location The board (DCU) location.

Configuration states are:

unconfigure Transitions an assigned board to the connected/unconfigured state. The hardware resources on the board can no longer be used by Solaris software.

disconnect Transitions an assigned board to the disconnected/unconfigured state.

unassign Unassigns the board from the logical domain. The board no longer belongs to the domain and its state is changed to available.

If the *-c function* option is not specified, the default expected configuration state is *unassign*. For more detailed information on the configuration states refer to the *deleteboard(1M)* manpage.

Multiple locations are accepted.

The following *location* forms are accepted:

Valid form for Sun Fire 15K	Valid form for Sun Fire 12K
SB(0...17)	SB(0...8)
IO(0...17)	IO(0...8)

For example:

```
sc0:sms-user:> deleteboard -c unassign SB0
```

SB0 has now gone from being assigned to the domain to being available to it.

Note – A domain administrator can unconfigure and disconnect a board but is not allowed to delete a board from a domain unless the `deleteboard [location]` field appears in the domain's available component list.

If `deleteboard` fails, the board does not return to its original state. A `dxs` or `dca` error is logged to the domain and `pcd` reports an error to the platform log file. If the error is recoverable, you can retry the command. If it is *unrecoverable*, you need to reboot the domain in order to use that board.

▼ To Move Boards Between Domains From the Command Line

Note – You must have domain administrator privileges for both domains involved.

1. Log in to the SC as a domain administrator for that domain.

The system board must be in the assigned or active state to the domain from which it is being deleted. Use the `showboards (IM)` command to determine a board's state.

2. Type:

```
sc0:sms-user:> moveboard -d domain_indicator -c function location
```

where:

- | | |
|---|---|
| <code>-d <i>domain_indicator</i></code> | This is the domain to which the board is being moved. Specifies the domain using:

<i>domain_id</i> - ID for a domain. Valid <i>domain_ids</i> are A-R and are not case sensitive.

<i>domain_tag</i> - Name assigned to a domain using <code>addtag(1M)</code> . |
| <code>-c <i>function</i></code> | Specifies the transition of the board from the current configuration state to an new configuration state. |
| <i>location</i> | The board (DCU) location. |

Configuration states are:

- | | |
|------------------------|---|
| <code>assign</code> | Unconfigures the board from the current logical domain. Moves the board out of the logical domain by changing its state to <code>available</code> . Assigns the board to the new logical domain. The board belongs to the new domain but is not active. |
| <code>connect</code> | Transitions an assigned board to the <code>connected/unconfigured</code> state. This is an intermediate state and has no standalone implementation. |
| <code>configure</code> | Transitions an assigned board to the <code>connected/configured</code> state. The hardware resources on the board can be used by Solaris software. |

If the `-c` option is not specified, the default expected configuration state is `configure`. For more detailed information on the configuration states refer to the `moveboard(1M)` manpage.

The following *location* forms are accepted:

Valid form for Sun Fire 15K	Valid form for Sun Fire 12K
SB(0...17)	SB(0...8)
IO(0...17)	IO(0...8)

moveboard performs tasks synchronously and does not return control to the user until the command is complete. If the board is not powered on or tested specify `-c connect|configure`, then the command will power on the board and test it. You can only specify one *location* when using moveboard.

If moveboard fails, the board does not return to its original state. A `dxs` or `dca` error is logged to the domain and `pcd` reports an error to the platform log file. If the error is recoverable, you can retry the command. If it is *unrecoverable*, you need to reboot the domain the board was in when the error occurred, in order to use that board

▼ To Set Domain Defaults

In the event you wish to remove all instances of a previously active domain, SMS provides the `setdefaults(1M)` command.

1. Log in to the SC.

Domain administrators can set domain defaults for all domains, but only one domain at a time. The domain must *not* be active and `setkeyswitch` must be set to `off`. `setdefaults` removes all `pcd` entries except network information, log files and, optionally, NVRAM and boot parameter data.

2. Type:

```
sc0:sms-user:> setdefaults -d domain_indicator
```

where:

`-d domain_indicator` Specifies the domain using:

`domain_id` - ID for a domain. Valid `domain_ids` are A-R and are not case sensitive.

`domain_tag` - Name assigned to a domain using `addtag(1M)`.

For more information on `setdefaults` refer to the `setdefaults` man page or the *System Management Services (SMS) 1.4 Reference Manual*.

▼ To Obtain Board Status

1. Log in to the SC.

Domain administrators can obtain board status only for those domains for which they have privileges.

2. Type:

```
sc0:sms-user:> showboards [-d domain_id|domain_tag]
```

The board status is displayed.

The following partial example shows the board information for a user with domain administrator privileges for domain A.

```
sc0:sms-user:> showboards -d A
```

Location	Pwr	Type	Board Status	Test Status	Domain
-----	----	----	-----	-----	-----
SB1	On	CPU	Active	Passed	A
SB2	On	CPU	Active	Passed	A
IO1	On	HPCI	Active	Passed	A

▼ To Obtain Domain Status

1. Log in to the SC.

Domain administrators can obtain domain status only for those domains for which they have privileges.

2. Type:

```
sc0:sms-user:> showplatform -d domain_indicator
```

where:

`-d domain_indicator` Specifies the domain using:

domain_id - ID for a domain. Valid *domain_ids* are A-R and are not case sensitive.

domain_tag - Name assigned to a domain using `addtag(1M)`.

The status listing is displayed.

The following partial example shows the domain information for a user with domain administrator privileges for domains `newA`, `engB`, and `domainC`.

```
sc0:sms-user:> showplatform
...
Domain configurations:
=====
Domain ID Domain Tag      Solaris Nodename  Domain Status
A          newA                 sun15-b0         Powered Off
B          engB                 sun15-b1         Keyswitch Standby
C          domainC             sun15-b2         Running OBP
```

▼ To Obtain Device Status

1. Log in to the SC.

Domain administrators can obtain board status only for those domains for which they have privileges.

2. Type:

```
sc0:sms-user:> showdevices [-d domain_id|domain_tag]
```

The device status is displayed.

The following partial example shows the device information for a user with domain administrator privileges for domain A.

```
sc0:sms-user:> showdevices IO1
```

IO Devices

domain	location	device	resource	usage
A	IO1	sd3	/dev/dsk/c0t3d0s0	mounted filesystem "/"
A	IO1	sd3	/dev/dsk/c0t3s0s1	dump device (swap)
A	IO1	sd3	/dev/dsk/c0t3s0s1	swap area
A	IO1	sd3	/dev/dsk/c0t3d0s3	mounted filesystem "/var"
A	IO1	sd3	/var/run	mounted filesystem "/var/run"

Virtual Keyswitch

Each Sun Fire high-end system domain has a virtual keyswitch. Like the Sun Enterprise servers physical keyswitch, the Sun Fire high-end system domain virtual keyswitch controls whether the domain is powered on or off, whether increased diagnostics are run at boot, and whether certain operations (for example, flash PROM updates and domain `reset` commands) are permitted.

Only domains configured with their virtual keyswitch powered on are booted, monitored, and subject to automatic recovery actions, should they fail.

Virtual keyswitch settings are implemented using `setkeyswitch(1M)`. You must have domain administrator privileges for the specified domain in order to run `setkeyswitch`. See [“All Privileges” on page 23](#) for more information.

Setkeyswitch

`setkeyswitch(1M)` changes the position of the virtual key switch to the specified value. `pcd(1M)` maintains the state of each virtual key switch between power cycles of the SC or physical power cycling of the power supplies.

setkeyswitch(1M) is responsible for loading all the configured processors' bootbus SRAM. All the processors are started, with one processor designated as the boot processor. setkeyswitch(1M) loads OpenBoot PROM into the memory of the Product Name domain and starts OpenBoot PROM on the boot processor.

The primary task of OpenBoot PROM is to boot and configure the operating system from either a mass storage device or from a network. OpenBoot PROM also provides extensive features for testing hardware and software interactively.

The setkeyswitch(1M) command syntax follows:

```
sc0:sms-user:> setkeyswitch -d domain_indicator [-q -y|-n]  
on|standby|off|diag|secure
```

where:

- | | |
|----------------------------------|---|
| <code>-d domain_indicator</code> | Specifies the domain using:

<i>domain_id</i> - ID for a domain. Valid <i>domain_ids</i> are A-R and are not case sensitive.

<i>domain_tag</i> - Name assigned to a domain using addtag(1M). |
| <code>-q</code> | Quiet. Suppresses all messages to <code>stdout</code> including prompts. When used alone <code>-q</code> defaults to the <code>-n</code> option for all prompts. When used with either the <code>-y</code> or the <code>-n</code> option, <code>-q</code> suppresses all user prompts, and automatically answers with either Y or N based on the option chosen. |
| <code>-n</code> | Automatically answers no to all prompts. Prompts are displayed unless used with <code>-q</code> option. |
| <code>-y</code> | Automatically answers yes to all prompts. Prompts are displayed unless used with <code>-q</code> option. |

The following operands are supported:

- `on`
From the `off` or `standby` position, `on` powers on all boards assigned to the domain (if not already powered on). Then the domain is brought up.
From the `diag` position, `on` is nothing more than a position change and does not affect a running domain.
From the `secure` position, `on` restores write permission to the domain.
- `standby`

From the `on`, `diag`, or `secure` position, `standby` optionally displays a confirmation prompt. If you answer 'yes' then it determines if the domain is in a suitable state to be reset and deconfigured (for example, the OS is not running).

If the domain is in a suitable state to be reset and deconfigured, then `setkeyswitch` resets and deconfigures all boards assigned to the domain.

If not, then prior to the reset and deconfiguration `setkeyswitch` gracefully shuts down the domain.

From the `off` position, `standby` powers on all boards assigned to the domain (if not already powered on).

- `off`

From the `on`, `diag`, or `secure` position, `off` optionally displays a confirmation prompt. If you answer 'yes' then it determines if the domain is in a suitable state to be powered off (for example, the OS is not running).

If the domain is in a suitable state to be powered off, then `setkeyswitch` powers off all boards assigned to the domain.

If not, then `setkeyswitch` aborts and logs a message to the domain log.

From the `standby` position, `off` powers off all the boards in the domain.

- `diag`

From the `off` or `standby` position, `diag` powers on all boards assigned to the domain (if not already powered on). Then the domain is brought up just as in the `on` position, except that POST is invoked with verbosity and `diag` levels set to, at least, their defaults.

From the `on` position, `diag` is nothing more than a position change, but upon automatic system recovery (ASR) of the domain, POST is invoked with verbosity and the `diag` level set to, at least, their defaults.

From the `secure` position, `diag` restores write permission to the domain and upon ASR, POST is invoked with verbosity and the `diag` levels set to their defaults.

For more information on ASR, see [“Automatic System Recovery \(ASR\)” on page 145](#).

- `secure`

From the `off` or `standby` position, `secure` powers on all boards assigned to the domain (if not already powered on). Then the domain is brought up just as in the `on` position, except that the `secure` position removes write permission to the domain. For example, `flashupdate` and `reset` will not work.

From the `on` position, `secure` removes write permission to the domain (as described above). From the `diag` position, `secure` removes write permission to the domain (as described above).

▼ To Set the Virtual Keyswitch On in Domain A

1. Log in to the SC.

Domain administrators can set the virtual keyswitch only for those domains for which they have privileges.

2. Type:

```
sc0:sms-user:> setkeyswitch -d A on
```

`showkeyswitch (1M)` displays the position of the virtual keyswitch of the specified domain. The state of each virtual keyswitch is maintained between power cycles of the SC or physical power cycling of the power supplies by the `pcd (1M)`. Superuser or any member of a platform or domain group can run `showkeyswitch`.

▼ To Display the Virtual Keyswitch Setting in Domain A

1. Log in to the SC.

Domain administrators can obtain keyswitch status only for those domains for which they have privileges.

2. Type:

```
sc0:sms-user:> showkeyswitch -d A  
Virtual keyswitch position: ON
```

Virtual NVRAM

Each domain has a virtual NVRAM containing OpenBoot PROM data such as the OpenBoot PROM variables. OpenBoot PROM is a binary image stored on the SC in `/opt/SUNWSMS/hostobjs` which `setkeyswitch` downloads into domain memory at boot time. There is only one version of OpenBoot PROM for all domains.

SMS software provides a virtual NVRAM for each domain and allows OpenBoot PROM full read/write access to this data.

For most NVRAM variables, the only interface available to read or write them is OpenBoot PROM. The exceptions are those OpenBoot PROM variables which must be altered in order to bring OpenBoot PROM up in a known working state or to diagnose problems that hinder OpenBoot PROM bring up. These variables are not a replacement for the OpenBoot PROM interface.

These limited number of OpenBoot PROM variable values in the domain NVRAM are readable and writable from SMS using `setobpparams(1M)`. You must have domain administrator privileges to run `set/showobpparams`. If you change variables for a running domain, you must reboot the domain in order for the changes to take effect.

Note – Only experienced system administrators, familiar with OpenBoot PROM commands and their dependencies should attempt to use `setobpparams` in any manner other than that described.

Setting the OpenBoot PROM Variables

`setobpparams(1M)` sets and gets a subset of a domain's virtual NVRAM variables and REBOOTINFO data using the following syntax.

```
sc0: sms-user:> setobpparams -d domain_indicator param=value...
```

where:

`-d domain_indicator` Specifies the domain using:

domain_id - ID for a domain. Valid *domain_ids* are A–R and are not case sensitive.

domain_tag - Name assigned to a domain using `addtag(1M)`.

param=value is:

Variables	=	Default Value	Comment
diag-switch?	=	false	When set to false, the default boot device is specified by <code>boot-device</code> and the default boot file by <code>boot-file</code> . If set to true, OpenBoot PROM runs in diagnostic mode and you need to set either <code>diag-device</code> or <code>diag-file</code> to specify the correct default boot device or file. These default boot device and file settings cannot be set using <code>setobpparams</code> . Use <code>setenv(1)</code> in OpenBoot PROM.
auto-boot?	=	false	When set to true, the domain boots automatically after power-on or reset-all. The boot device and boot file used are based on the settings for <code>diag-switch</code> (see above). Neither <code>boot-device</code> nor <code>boot-file</code> can be set using <code>setobpparams</code> . In the event the OK prompt is unavailable, such as a repeated panic, use <code>setobpparams</code> to set <code>auto-boot?</code> to false. When the <code>auto-boot?</code> variable is set to false using <code>setobpparams</code> , the reboot variables are invalidated, the system will not boot automatically and will stop in OpenBoot PROM where new NVRAM variables can be set. See “To Recover From a Repeated Domain Panic” on page 97 .
security-mode	=	none	Firmware security level. Valid variable values for <code>security-mode</code> are: <ul style="list-style-type: none"> • none - No password required (default). • command - All commands except for <code>boot(1M)</code> and <code>go</code> require the password. • full - All commands except for <code>go</code> require the password.
use-nvramrc?	=	false	When set to true, this variable executes commands in NVRAMRC during system start-up.
fcode-debug?	=	false	When set to true, this variable includes name fields for plug-in device FCodes.

The following is an example of how `setobpparams` can be useful.

▼ To Recover From a Repeated Domain Panic

Say domain A encounters repeated panics caused by a corrupted default boot disk.

1. Log in to the SC with domain administrator privileges.
2. Stop automatic reboot:

```
sc0:sms-user:> setkeyswitch -d A standby
sc0:sms-user:> setobpparams -d A 'auto-boot?=false'
```

Note – Most, but not all, shells require using single quotes around the variable values to prevent the question mark from being treated as a special character.

3. Repost the domain:

```
sc0:sms-user:> setkeyswitch -d A off
sc0:sms-user:> setkeyswitch -d A on
```

4. Once the domain has come up to the OK prompt set NVRAM variables to a new uncorrupted boot-device.

```
ok setenv boot-device bootdisk_alias
```

where:

bootdisk_alias A user-defined alias you created. The boot device must correspond to the a bootable disk on which you have installed the operating environment.

5. Now that you have set up a new alias for your boot device, boot the disk by typing:

```
ok boot
```

For more information on OpenBoot variables refer to the *OpenBoot 4.x Command Reference Manual*.

▼ To Set the OpenBoot PROM Security Mode Variable in Domain A

1. Log in to the SC.

Domain administrators can set the OpenBoot PROM variables only for those domains for which they have privileges.

2. Type:

```
sc0:sms-user:> setobpparams -d A security-mode=full
```

`security-mode` has been set to full. All commands except `go` require a password on domain A. You must reboot a running domain in order for the change to take effect.

▼ To See the OpenBoot PROM Variables

1. Log in to the SC.

Domain administrators can set the OpenBoot PROM variables only for those domains for which they have privileges.

2. Type:

```
sc0:sms-user:> showobpparams -d domain_indicator
```

where:

`-d domain_indicator` Specifies the domain using:

domain_id - ID for a domain. Valid *domain_ids* are A-R and are not case sensitive.

domain_tag - Name assigned to a domain using `addtag(1M)`.

SMS NVRAM updates are supplied to OpenBoot PROM at OpenBoot PROM initiation (or domain reboot time). For more information refer to the *OpenBoot PROM 4.x Command Reference Manual*.

Degraded Configuration Preferences

In most situations, hardware failures that cause a domain crash are detected and eliminated from the domain configuration either by POST or OpenBoot PROM during the subsequent automatic recovery boot of the domain. However, there can be situations where failures are intermittent or the boot-time tests are inadequate to detect failures that cause repeated domain failures and reboots. In those situations, Sun Fire high-end system management software uses configurations or configuration policies supplied by the domain administrator to eliminate hardware from the domain configuration in an attempt to get a stable domain environment running.

The following commands can be run by either platform or domain administrators. Domain administrators are restricted to the domains for which they have privileges.

Setbus

`setbus(1M)` dynamically reconfigures bus traffic on active expanders in a domain to use either one centerplane support board (CSB) or both. Using both CSBs is considered *normal* mode. Using one CSB is considered *degraded* mode.

`setbus` resets any boards that are powered on but not active. Any attach-ready state is lost. For more information on attach-ready states refer to the *System Management Services (SMS) 1.4 Dynamic Reconfiguration User Guide*.

You must have platform administrator privileges or domain privileges for the specified domain in order to run `setbus`.

This feature allows you to swap out a CSB without having to power off the system. Valid buses are:

- a - configures the address bus
- d - configures the data bus
- r - configures the response bus

▼ To Set All Buses on All Active Domains to Use Both CSBs

1. Log in to the SC.

Domain administrators can set the bus only for those domains for which they have privileges.

2. Type:

```
sc0:sms-user:> setbus -c CS0,CS1
```

For more information on reconfiguring bus traffic, refer to the `setbus(1M)` man page.

Showbus

`showbus(1M)` displays the bus configuration of expanders in active domains. This information defaults to displaying configuration by slot order. Any member of a platform or domain group can run `showbus`.

▼ To Show All Buses on All Active Domains

1. Log in to the SC.

Domain administrators can set the bus only for those domains for which they have privileges.

2. Type:

```
sc0:sms-user:> showbus
```

For more information on reconfiguring bus traffic, refer to the `showbus(1M)` man page.

Automatic Diagnosis and Recovery

This chapter describes the automatic error diagnosis and domain recovery features included with SMS, starting with the SMS 1.4 release. This chapter covers the following topics:

- [Automatic Diagnosis and Recovery Overview](#)
 - [Enabling Email Event Notification](#)
 - [Testing Email Event Notification](#)
 - [Obtaining Diagnosis and Recovery Information](#)
-

Automatic Diagnosis and Recovery Overview

When certain hardware errors occur in a Sun Fire high-end system, the system controller performs specific diagnosis and domain recovery steps. The following automatic diagnosis engines (DEs) identify and diagnose hardware errors that affect the availability of the system and its domains:

- SMS diagnosis engine
 - The SMS DE diagnoses hardware errors associated with domain stops (dstops).
- Solaris operating environment
 - The Solaris operating environment (also referred to as the Solaris DE) identifies non-fatal domain hardware errors and reports them to the system controller.
- POST diagnosis engine
 - The POST DE identifies any hardware test failures that occur when the power-on self-test is run.

The following sections describe the diagnosis and recovery steps that occur for the hardware errors identified by the different diagnosis engines.

Hardware Errors Associated with Domain Stops

FIGURE 5-1 shows the basic diagnosis and domain recovery steps performed when hardware errors associated with a dstop are identified by the SMS diagnosis engine.

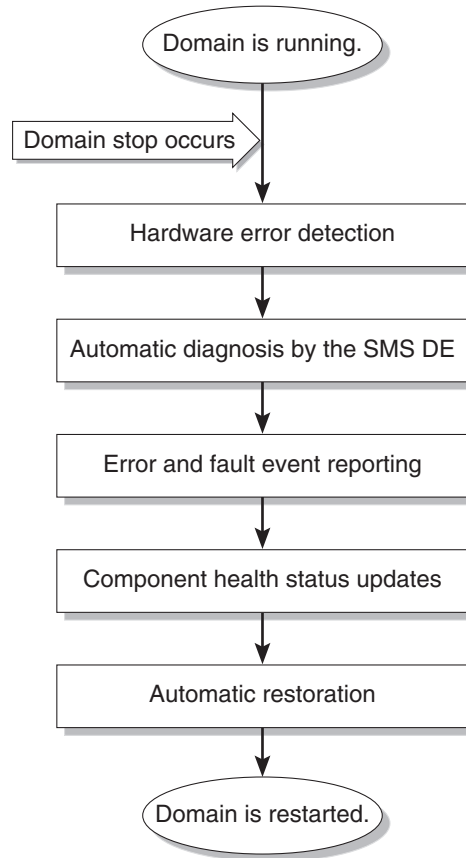

FIGURE 5-1 Automatic Diagnosis and Recovery Process for Hardware Errors Associated with a Stopped Domain

The following summary describes the process shown in FIGURE 5-1.

- **Hardware error detection.** The system controller provides information on hardware errors involving CPU boards, processors, I/O controllers, and memory banks.

A dump file is generated whenever a dstop occurs. This file (`/var/opt/SUNWSMS/sms_version/adm/domain_id/dump/dsmd.dstop.yymmdd.hhmm.ss`) captures the domain hardware errors associated with the dstop.

- **Automatic diagnosis.** The SMS DE determines a failure based on the hardware errors captured in the dstop dump file. The DE may identify one or more FRUs that are responsible for the error. Depending on the hardware error, the DE may identify one faulty FRU or one or more suspect FRUs.

In situations where multiple FRUs are identified by the DE, further analysis by your service provider may be required to determine the faulty FRU.

- **Error and fault event reporting.** The DE reports diagnosis information through the following:
 - Auto-diagnosis fault messages that appear in the domain and platform log files.

[CODE EXAMPLE 5-1](#) shows the information displayed for a domain stop and the auto-diagnosis message that describes a fault event on domain D. The event message begins with the [AD] indicator. See [“Reviewing Diagnosis Events” on page 117](#) for a description of the event message contents.

CODE EXAMPLE 5-1 Example of a Dstop and Auto-Diagnosis Event Message in the Platform Log File

```
Jul 30 14:23:26 2003 smshostname dsmd[14838]-D(): [2516 589424843782403 ERR
EventHandler.cc 136] Domain stop has been detected in domain D
Jul 30 14:23:27 2003 smshostname dsmd[14838]-D(): [2525 589425136691417 NOTICE
SysControl.cc 2360] Taking hardware configuration dump. Dump
file: -D/var/opt/SUNWSMS/SMS1.4/adm/D/dump/dsmd.dstop.030730.1423.27
Jul 30 14:24:37 2003 smshostname erd[14864]-D(): [11900 589495236849691 CRIT Mes
sageReportingService.cc 381] [AD] Event: SF15000-8000-GK CSN: 352A00005
DomainID: D ADInfo: 1.SMS-DE.1.4 Time: Wed Jul 30 14:23:27 PDT 2003
Recommended-Action: Service action required
```

- Email notification of fault events. For details, see [“Enabling Email Event Notification” on page 107](#).
- Fault event notification if you are using Sun Management Center. For details, refer to the *Sun Management Center 3.5 Version 2 Supplement for Sun Fire 15K/12K Systems*.
- Notification of fault events if you are using Sun Remote Services Net Connect and have configured Net Connect accordingly.

For general information on SRS Net Connect, refer to

<http://www.sun.com/srs>

For SRS Net Connect product documentation, refer to

<https://srsnetconnect3.sun.com>

and

<http://docs.sun.com>

- Event log output from the `showlogs (1M)` command if you have platform administrator privileges

The `showlogs` event output supplements the diagnosis information presented in the platform and domain message logs or the event email. The `showlogs` event output can be used for additional troubleshooting purposes by your service provider. For details on the event information displayed, see [“Obtaining Diagnosis and Recovery Information” on page 117](#).

Note – Contact your service provider when you see these event messages or when you are notified of these events. Your service provider will review the auto-diagnosis information and initiate the appropriate service action.

- **Component health status updates.** The SMS DE records the diagnosis information for each affected component and maintains this health history as part of the component health status (CHS).
- **Automatic restoration.** As part of the domain restoration process, POST reviews the updated component health status of the affected components and uses the CHS information to determine which components to deconfigure from the system. The appropriate components are then deconfigured, and the domain is restarted.

Non-Fatal Domain Hardware Errors

[FIGURE 5-2](#) shows the basic steps involved in the diagnosis of non-fatal domain hardware errors. These errors do not cause a domain to stop.

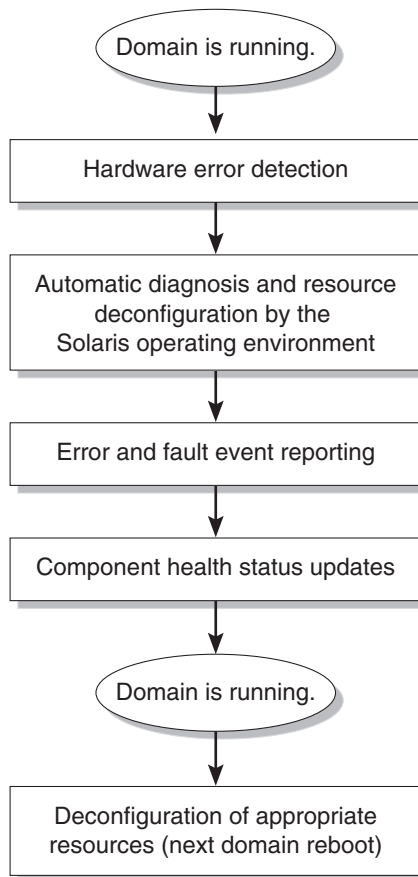

FIGURE 5-2 Automatic Diagnosis Process for Non-Fatal Domain Hardware Errors

The steps shown in [FIGURE 5-2](#) are similar to the steps discussed in the section [“Hardware Errors Associated with Domain Stops”](#) on page 102, except for the following differences:

- **Hardware error detection.** The Solaris operating environment determines when a non-fatal domain hardware error has occurred and reports the error to the system controller. The affected domain is not stopped.
- **Automatic diagnosis and resource deconfiguration.** The Solaris operating environment identifies the failure and the resources that caused the failure. If appropriate, the Solaris operating environment may also deconfigure the affected resources. For example, a CPU module may be taken off-line because of non-fatal errors that occur within the module, or a virtual memory page may be retired due to errors contained in the page.

- **Error and fault event reporting.** The Solaris operating system provides diagnosis information through the same channels as the SMS DE: event messages that appear in the domain and platform logs, fault event notification if using Sun Management Center, or email event notification within SMS or through SRS Net Connect if you configured those features, and `showlogs(1M)` event output.

[CODE EXAMPLE 5-2](#) shows the diagnosis of a non-fatal hardware error and the event message information displayed. The event message begins with the [DOM] indicator. See [“Reviewing Diagnosis Events” on page 117](#) for a description of the event message contents.

CODE EXAMPLE 5-2 Example of a Non-Fatal Domain Hardware Error Identified by Solaris and the Domain Event Message

```
Sep 12 14:47:24 2003 smshostname dsmd[7839]: [0 876197473671508 ERR
SoftErrorHandler.cc 577] E$ Slot 3 SubSlot 5
Sep 12 14:47:25 2003 smshostname dsmd[7839]: [2552 876198449525014 ERR
SoftErrorHandler.cc 592] Soft Error: Comp ID : 0x62 Error Code: 3 Error Type: 1
Error Bit/Pin: 104
Sep 12 14:47:58 2003 smshostname erd[17227]: [11900 876231607099583 CRIT
MessageReportingService.cc 243] [DOM] Event: SF15000-8000-FF CSN: 352A00006
DomainID: D ADInfo: 1.SF-SOLARIS-DE.5-9-cs3:4791004-on81:08/18/2003 Time: Fri
Sep 12 14:47:38 PDT 2003 Recommended-Action: Service action required
```

Note – Contact your service provider when you see these event messages or when you are notified of these events. Your service provider will review the auto-diagnosis information and initiate the appropriate service action.

- **Component health status updates.** SMS updates the component health status of the affected hardware resources, using the information supplied by the Solaris operating environment.
- **Deconfiguration of appropriate resources.** In cases where the Solaris operating environment could not previously deconfigure faulty domain resources, those resources are deconfigured from the system at the next domain reboot.

POST-Detected Hardware Failures

Whenever POST is run to test and configure system board components, any components that fail the self-test are automatically deconfigured from the system. POST updates the component health status of the affected components accordingly.

[CODE EXAMPLE 5-3](#) shows an auto-diagnosis event message reported by the POST DE for domain B. See [“Reviewing Diagnosis Events” on page 117](#) for a description of the event message contents.

CODE EXAMPLE 5-3 Example of a POST Auto-Diagnosis Event Message

```
Sep  8 13:31:16 2003 smshostname erd[11987]: [11900 240509936296585 C
RIT
MessageReportingService.cc 243] [AD] Event: SF15000-8000-4L CSN: 352A00005
DomainID: B ADInfo: 1.POST-DE.1.4 Time: Mon Sep  8 13:30:47 PDT 2003
Recommended-Action: Service action required
```

When you see these messages or when you are notified of these events, contact your service provider to initiate the appropriate service action.

Enabling Email Event Notification

Email event notification is an optional feature that automatically generates an email notice informing designated recipients of domain fault events when they occur. You can receive immediate notice of critical fault events, without manually monitoring the platform or domain message logs.

[CODE EXAMPLE 5-4](#) shows an example email that reports a fault event in which two components are indicted (suspected of causing a fault). The following sections explain how to control email content and notification.

CODE EXAMPLE 5-4 Example Event Email

```
Date: Tue, 19 Aug 2003 10:45:28 -0600 (MDT)
Subject: FAULT: SF15000, csn: 352A00007, main fault class: list.suspects
From: smshostname@xyz.com
To: undisclosed-recipients;;

FAULT: platform: SF15000, csn: 352A00007, main fault class: list.suspects
EVENT CODE: SF15000-8000-GK
EMBEDDED FAULT(S): fault.board.sb.1112
fault.board.ex.1112

Fault event in domain(s) R at Fri Jun 27 00:08:05 PDT 2003.
Fault severity = SMIEVENT_SEV_FATAL <7>
Indictment Count: 2
Indictment list:
sb11
ex11
```

The following files work together to generate event email:

- Email template

This template identifies the event information to be reported in the email. This information includes the email subject line and specific event items (tags) to be reported in the email.

- Email control file (`event_email.cf`)

This file uses certain event information, namely the event class and the domain affected by the event, to assign the specified email recipients and email templates that control the event information to be reported.

Note – The event email feature uses the standard `sendmail` utility to send email to designated email recipients.

▼ To Enable Email Event Notification

1. **In the email template file, identify the event tags to be reported in email.**

Copy the sample email template (`sample_email`) provided with SMS and edit the copied file. For details on modifying the email template, see [“Configuring an Email Template” on page 109](#).

2. **In the email control file, set the parameters that determine who receives the email and the email templates to be used.**

Edit the email control file (`event_email.cf`) included with SMS and assign the email notification parameters.

For details on modifying the control file, see [“Configuring the Email Control File” on page 111](#).

Note – If you use the email notification feature, review the email destination addresses to ensure that the recipients receive notifications for events pertaining only to the domains that they have authorization to see. Sun recommends that you implement and enforce a process for maintaining appropriate security separation whenever people change responsibilities and gain or lose authorization.

Configuring an Email Template

A sample email template file called `sample_email` (`/etc/opt/SUNWSMS/SMS/config/templates`) is provided with SMS. [CODE EXAMPLE 5-5](#) shows the default template. The text in angle brackets serves as tags that identify the event information to be displayed in the body of the event email.

CODE EXAMPLE 5-5 Default Sample Email Template

```
# Sample Email Template File - This sample is intended to convey
# a terse fault event notification to a pager.
#
# The following is the subject line for the email with the event
# descriptor from the event and the platform model and serial
# number inserted.
#
FAULT: <PLATFORM_MODEL>, serial# <PLATFORM_SERIAL_NUMBER>, code <EVENT_CODE>
#
# The following lines are the body of the email notification.
#
Fault event in domain(s) <EVENT_DOMAINS_AFFECTED> at <EVENT_TIMESTAMP>.
Fault severity = <EVENT_SEVERITY>

Indictment Count: <EVENT_INDICTMENT_COUNT>
Indictment list:
<EVENT_INDICTMENT_LIST>

Member fault list:
<EVENT_FAULT_MEMBERS>
# End of email template.
```

You can use the sample template file as is, or you can copy the sample template file to a new file, which can be edited to identify additional or different event tags to be contained in the email. You must have superuser privileges to copy and rename the sample template file. The name of the file can be any text string that you choose.

When you edit the file, specify the event tags to be reported in the email subject line and email body. Specify these tags on new, uncommented lines in the file (lines that do not begin with a # sign). For a list of the tags that can be specified in the email template, see [TABLE 5-1](#).

TABLE 5-1 Event Tags in the Email Template File

Event Tag	Information Displayed
<EVENT_CLASS>	A dot-separated alphanumeric text string that describes the event category (error report, fault event, or a list of suspected faults). For example: <code>list.suspects</code>
<EVENT_CODE>	A dash-separated alphanumeric text string that uniquely identifies an event type, for example: <code>SF15000-8000-GK</code> . The event code summarizes the fault classes involved in the event and is used by your service provider to obtain further information about the event.
<EVENT_DE_NAME>	Name of the diagnosis engine (DE) used to determine the fault event: <code>SMS-DE</code> , <code>SF-SOLARIS-DE</code> , or <code>POST-DE</code> .
<EVENT_DE_VERSION>	Version of the diagnosis engine used to determine the event.
<EVENT_DOMAINS_AFFECTED>	A comma-separated list of domains affected by the event.
<EVENT_FAULT_MEMBERS>	List of fault event classes associated with the fault event. For example: <code>fault.board.sb.1112</code>
<EVENT_INDICTMENT_COUNT>	Number of components indicted or suspected of causing the fault event.
<EVENT_INDICTMENT_LIST>	The indicted components. Each component is listed on a separate line.
<EVENT_SEVERITY>	The severity of the event, ranging from 0 to 7. For example, test event messages have a severity level 2 and fault events that cause a domain stop have a severity level 7 (<code>SMIEVENT_SEV_FATAL</code>).
<EVENT_TIMESTAMP>	The day and time of the event.
<PLATFORM_SERIAL_NUMBER>	The chassis serial number that identifies the Sun Fire high-end system.
<PLATFORM_MODEL>	The number of the product model (<code>SF15000</code> or <code>SF12000</code>) affected by the event.

[FIGURE 5-3](#) shows the email template used to generate the email example shown in [CODE EXAMPLE 5-4](#).

Custom Email Template:

```
# Sample Email Template File - This sample is intended to convey
# a terse fault event notification to a pager.
#
# The following is the subject line for the email with the event
# descriptor from the event and the platform model and serial
# number inserted.
#
FAULT: platform: <PLATFORM_MODEL>, csn: <PLATFORM_SERIAL_NUMBER>, main fault class: <EVENT_CLASS>
EVENT CODE: <EVENT_CODE>
EMBEDDED FAULT(S): <EVENT_FAULT_MEMBERS>
#
# The following lines are the body of the email notification.
#
Fault event in domain(s) <EVENT_DOMAINS_AFFECTED> at <EVENT_TIMESTAMP>.
Fault severity = <EVENT_SEVERITY>

Indictment Count: <EVENT_INDICTMENT_COUNT>
Indictment list: <EVENT_INDICTMENT_LIST>
# End of email template.
```

Generates Email for the Following Fault Events:

```
Date: Tue, 19 Aug 2003 10:45:28 -0600 (MDT)
Subject: FAULT: platform: SF15000, csn: 352A00007, main fault class: list.suspects
From: smshostname@xyz.COM
To: undisclosed-recipients;;

FAULT: platform: SF15000, csn: 352A00007, main fault class: list.suspects
EVENT CODE: SF15000-8000-GK
EMBEDDED FAULT(S): fault.board.sb.1112
fault.board.ex.1112

Fault event in domain(s) R at Tue Aug 19 10:45:18 MDT 2003.
Fault severity = SMIEVENT_SEV_INFO <?>

Indictment Count: 2
Indictment list:
sb11
ex11
```

FIGURE 5-3 Example Email Template and Generated Email

Configuring the Email Control File

The email control file contains the email notification parameters that do the following:

- Identify the email recipients based on the event class and the domain in which the event occurred
- Identify the email templates to be used
- Indicate whether the event message structure is to be sent as an attachment with the event email

You specify these notification parameters in the email control file supplied with SMS (/etc/opt/SUNWSMS/SMS/config/event_email.cf). This file, shown in [CODE EXAMPLE 5-6](#), contains comment lines that begin with a pound (#) sign. These comment lines explain how to update the file.

CODE EXAMPLE 5-6 Email Control File (event_email.cf)

```
#
# Copyright (c) 2003 by Sun Microsystems, Inc.
# All rights reserved.
#
# Email Control File
#
# ident "@(#)event_email.cf 1.5      03/08/19 SMI"
#
# The following fields are required to receive email notification of fault
# events
# Event_Class Domains Template From Include-event? Recipients Script
# Event_Class and Domains are regular expressions filtering for specific event
# types and affected domains. Domains are required to be upper case.
# The following example, uncommented, generates an email for any List Event
# containing a Fault Event, affecting any domain, and sends it to
# two recipients.
# The Packed Event List is included as an attachment to the email.
#
# Event_Class Domains Template From Include-event? Recipients Script
#^fault[.] [A-R] sample_email FMA@xyz.com Y adm@xyz.com,adm2xyz.com sendmail.sh
#
#
# The following example, uncommented, generates an email for any Event
# that contains a Fault Event and affects domains A through C. The Packed
# Event List is not sent as an attachment. The user would be required to add his
# custom fault_email template to the directory
# /etc/opt/SUNWSMS/config/templates, and for tag
# replacement to work should refer to the documentation, or look at the
# sample_email template in that directory.
#^fault[.] [A-C] fault_email FMA@xyz.com N admin.manager@xyz.com sendmail.sh
```

Use a text editor to edit the file and add the notification parameters in new, uncommented lines. You must have superuser privileges to edit the email control file and add the required email parameters. Separate each parameter with spaces or tabs. You can enter multiple notification lines that control how different event email messages are to be distributed, perhaps by domain, event class, or email template. The notification parameters that you configure are described in [TABLE 5-2](#).

You can use regular expressions to specify ranges or specific matches for the *Event_Class* and *Domains* parameters. The email control file supports extended regular expressions (REs) as explained in the `regex(5)` man page. Some examples of valid regular expressions include:

- `.` (period) – Matches any single character.
- `^` (circumflex) – Forces a match to start at the beginning of the string. For example, `^fault` matches any string that starts with `fault`.
- `[BDG]` – Matches any single character, B or D or G.
- `[B-F]` – Matches any single character ranging between B and F, such as B and C or D or E or F.

TABLE 5-2 Email Control File Parameters

Email control parameter	Description
<i>Event_Class</i>	The fault event class to be used as a filter. Specify the event class as a regular expression, so that this parameter can apply to a wide range of event classes. For example, the default format <code>fault.*</code> causes all fault events that match the string <code>fault</code> to be reported in the event email.
<i>Domains</i>	The domains to be used as filters. The default format <code>[A-R]</code> causes the fault events from domains A through R to be identified in the email. The domains must be specified in uppercase letters.
<i>Template</i>	The name of the email template file to be used to generate the email contents.
<i>From</i>	The email alias from which the email is generated.
<i>Include-event?</i>	One of the following states: <ul style="list-style-type: none"> • <code>Y</code> – Yes, include the binary file of the event message structure as an email attachment. This file can be used by your service provider for troubleshooting purposes. • <code>N</code> – No, do not include the binary file of the event message structure as an email attachment.
<i>Recipients</i>	The email aliases of the individuals to receive the event email. Separate each alias with a comma.
<i>Script</i>	The shell script used to send the email to the designated recipients. The <code>sendmail.sh</code> script in <code>/etc/opt/SUNWSMS/config/scripts</code> is the standard script, but you can replace this with your own custom script in the same directory.

[CODE EXAMPLE 5-7](#) shows an updated email control file in which notification parameters have been added to the bottom of the file. The `sendmail.sh` script will be used to send event email to the two specified recipients. An event email will be generated for all fault events that occurred in domains A through C and will be formatted based on the template file called `sample_email`. The event message structure will be sent as a binary file attachment that accompanies the email.

CODE EXAMPLE 5-7 Sample Email Control File

```
#
# Copyright (c) 2003 by Sun Microsystems, Inc.
# All rights reserved.
# Email Control File
#
# ident "@(#)event_email.cf 1.1      03/03/12 SMI"
#
# The following fields are required to receive email notification of fault
# events
# Event_Class Domains Template From Include-event? Recipients-Script
# Event_Class and Domains are regular expressions filtering for specific event
# types and affected domains. Domains are required to be upper case.
# The following example, uncommented, generates an email for any List Event
# containing a Fault Event, affecting any domain, and sends it to
# two recipients. Recipients are email addresses separated by commas if there
# are more than 1. Embedded blanks are not permitted in the Recipients list.
# The Packed Event List is included as an attachment to the email.
#
# Event_Class Domains Template From Include-event? Recipients Script
#^fault[.] [A-R] sample_email FMA@xyz.com Y adm1@xyz.com,adm2@xyz.com sendmail.sh
#
#
# The following example, uncommented, generates an email for any Event
# that contains a Fault Event and affects domains A through C. The Packed
# Event List is not sent as an attachment. The user would be required to add his
# custom fault_email template to the directory
# /etc/opt/SUNWSMS/config/templates, and for tag
# replacement to work should refer to the documentation, or look at the
# sample_email template in that directory.
#
#^fault[.] [A-C] sample_email FMA@xyz.com Y adm1@xyz.com,adm2@xyz.com sendmail.sh
^fault[.] [A-C] sample_email FMA@xyz.com Y adm1@xyz.com,adm2@xyz.com sendmail.sh
```

Testing Email Event Notification

Use the `testemail(1M)` command to verify email event notification. This command also enables you to track events and check any changes to the email control file.

▼ To Test Email Event Notification

1. Set up the email event templates and the email control file as described in [“Enabling Email Event Notification” on page 107](#).
2. In an SC window, log in as platform administrator or platform service and type:

```
sc0:sms-user:> /opt/SUNWSMS/SMS1.4/lib/smsadmin/testemail -c
event_class_list -d domain_id [-i resource_indictment_list]
```

where:

event_class_list is a list of one or more fault event classes to be tracked

domain_id specifies a single domain, A-R

resource_indictment_list is an optional list of one or more components that map to each event class specified. For a list of the valid component values, refer to the `testemail(1M)` man page.

For example, the following command

```
sc0:sms-user:> /opt/SUNWSMS/SMS1.4/lib/smsadmin/testemail -c
fault.test.email -d A
```

generates an event of type `fault.test.email` originating on domain A.

3. Verify that the test event was recorded in the platform or domain message logs.

For example, a message similar to the following is displayed in the platform message log:

```
Aug 19 10:45:28 2003smshostname [6696:1]: [11917 682823530704603 ERR teste
mailApp.cc 345] Test fault with code SF15000-8000-Y1 generated by user root
using testEmailReporting - please ignore
```

4. If the test event was successfully recorded in the message logs, verify that the designated recipients received the test email.

For example, the test email might resemble the following:

```
Date: Tue, 19 Aug 2003 10:45:28 -0600 (MDT)
Subject: FAULT: SF15000, serial# 352A0008, code SF15000-8000-Y1
From: smshostname@xyz.com
To: undisclosed-recipients:;

FAULT: SF15000, serial# 352A0008, code SF15000-8000-Y1
Fault event in domain(s) A at Tue Aug 19 10:45:18 MDT 2003.
Fault severity = SMIEVENT_SEV_INFO <2>
Indictment Count: 0
Indictment list:

Member fault list:
fault.test.email
```

If the test email was not generated, review the next section for troubleshooting suggestions.

What To Do If Test Email Fails

If you did not receive test email notification, do the following:

1. Review your email event templates and the email control file to verify that the files have been set up correctly.
2. Check the domain and platform message logs to verify that the test events were recorded.
3. Verify that the sendmail daemon is running. For example:

```
sc0:sms-user:> ps -ef | grep sendmail
  root   256      1  0   Aug 06  ?        0:05 /usr/lib/sendmail -bd -q15m
 sms-user 525 28546  0 21:23:15 pts/27  0:00 grep sendmail
```

If the sendmail daemon is not running, you might have a problem with your installation setup that requires correction. Proceed to Step 4.

4. Manually start `sendmail`, which will run until the next reboot, by logging on as superuser and restarting the `sendmail` daemon:

```
sc0:# /usr/lib/sendmail -bd -q15m &
```

5. Check `/var/log/syslog` on the SC to see if email was sent by the Mail Transfer Agent (MTA), `sendmail`.

If `sendmail` is not configured or was configured incorrectly, error messages would appear in this log file.

6. Verify that the domain and nameserver IP entries (to route the email messages outside of the system controller) exist in the `/etc/resolv.conf` file.
7. Restart `sendmail.sh`:

```
sc0:#:/etc/inet.d/sendmail stop
sc0:#:/etc/inet.d/sendmail start
```

Obtaining Diagnosis and Recovery Information

This section describes the various ways to monitor diagnostic errors and obtain additional information about fault and error events.

Reviewing Diagnosis Events

Automatic diagnosis [AD] and domain [DOM] event messages are displayed on the platform and domain console or in the `syslog` host, if a `loghost` server was configured. The [AD] or [DOM] event messages (see [CODE EXAMPLE 5-1](#), [CODE EXAMPLE 5-2](#), and [CODE EXAMPLE 5-3](#)) include the following information:

- [AD] or [DOM] – Beginning of the message. AD indicates that the SMS or POST automatic diagnosis engine generated the event message. DOM indicates that the Solaris operating environment on the affected domain generated the automatic diagnosis event message.
- Event – The event code, a dash-separated alphanumeric text string that uniquely identifies an event type. This code is used by your service provider to obtain further information about the event and the platform involved.
- CSN – Chassis serial number, which identifies your Sun Fire high-end system.

- `DomainID` – The domain affected by the hardware error. Valid domains are A through R.
- `ADInfo` – The version of the auto-diagnosis message, the name of the diagnosis engine (SMS-DE, SF-SOLARIS-DE, or POST-DE), and the diagnosis engine version (the SMS version or the version of Solaris operating environment in use).
- `Time` – The day of the week, month, time (hours, minutes, and seconds), time zone, and year of the auto-diagnosis.
- `Recommended-Action: Service action required` – Instructs the platform or domain administrator to contact their service provider for further service action. Also indicates the end of the auto-diagnosis message.

Reviewing the Event Log

If you have platform administrator or platform service privileges, you can use the `showlogs` command to view the contents of the event log, to obtain more detailed information about a particular type of event. The information displayed can also be used by your service provider for troubleshooting purposes.

You can obtain information on the following types (classes) of events recorded in the event log:

- `Ereports` – Error reports provide data on unexpected component behavior or conditions.
- `List events` – List events provide a list of fault events or suspected faults associated with a hardware error.

[TABLE 5-3](#) describes some of the various ways to view event information through the `showlogs` command.

TABLE 5-3 `showlogs(1M)` Command Options for Displaying Error and Fault Event Information

Command Options	Description
<code>showlogs -E -p e</code>	Displays the last event in the event log in a condensed format.
<code>showlogs -E -p e number</code>	Displays the event data for the last <i>number</i> of events in a condensed format. For example, <code>showlogs -E -p e 3</code> displays condensed event information for the last three events in the event log.
<code>showlogs -p e list</code>	Displays the last list event in the event log.

TABLE 5-3 showlogs(1M) Command Options for Displaying Error and Fault Event Information

Command Options	Description
<code>showlogs -p e ereport</code>	Displays the last ereport (error report) in the event log. An error report contains specific information about the hardware entity, such as an unexpected condition or behavior.
<code>showlogs -d domain_ID -p e number</code>	Displays the last <i>number</i> of events in the specified domain.
<code>showlogs -E -p e event_code</code>	Displays condensed event log information for the specified event code.

For details on the showlogs command options and examples of event output, refer to the showlogs(1M) command description in the *System Management Services (SMS) 1.4 Reference Manual*.

Capacity on Demand

Product Names are configured with processors (CPUs) on CPU/Memory boards. These boards are purchased as part of your initial system configuration or as add-on components. The right to use the CPUs on these boards is included with the initial purchase price.

The Capacity on Demand (COD) option provides additional processing resources that you pay for when you use them. Through the COD option, you purchase and install unlicensed COD CPU/Memory boards in your system. Each COD CPU/Memory board contains four CPUs, which are considered as available processing resources. However, you do not have the right to use these COD CPUs until you also purchase the right-to-use (RTU) licenses for them. The purchase of a COD RTU license entitles you to receive a license key, which enables the appropriate number of COD processors.

You use COD commands included with the SMS software to allocate, activate, and monitor your COD resources.

This chapter covers the following topics:

- [COD Overview](#)
- [Getting Started with COD](#)
- [Managing COD RTU Licenses](#)
- [Activating COD Resources](#)
- [Monitoring COD Resources](#)

COD Overview

The COD option provides additional CPU resources on COD CPU/Memory boards that are installed in your system. Although your Product Name comes configured with a minimum number of standard (active) CPU/Memory boards, your system

can have a mix of both standard and COD CPU/Memory boards installed, up to the maximum capacity allowed for the system. At least one active CPU is required for each domain in the system.

If you want the COD option, and your system is not currently configured with COD CPU/Memory boards, contact your Sun sales representative or authorized Sun reseller to purchase COD CPU/Memory boards. Your salesperson will work with your service provider to install the COD CPU/Memory boards in your system.

The following sections describe the main elements of the COD option:

- [COD Licensing Process](#)
- [COD RTU License Allocation](#)
- [Instant Access CPUs](#)
- [Resource Monitoring](#)

COD Licensing Process

COD RTU licenses are required to enable COD CPU resources. COD licensing involves the following tasks:

1. Obtaining COD RTU license certificates and COD RTU license keys for COD resources to be enabled.

You can purchase COD RTU licenses at any time from your Sun sales representative or reseller. You can then obtain a license key (for the COD resources purchased) from the Sun License Center.

2. Entering the COD RTU license keys in the COD license database.

The COD license database stores the license keys for the COD resources that you enable. You record this license information in the COD license database by using the `addcodlicense(1M)` command. The COD RTU licenses are considered as floating licenses and can be used for any COD CPU resource installed in the system.

For details on completing the licensing tasks, see [“To Obtain and Add a COD RTU License Key to the COD License Database”](#) on page 125.

COD RTU License Allocation

With the COD option, your system is configured to have a certain number of COD CPUs available, as determined by the number of COD CPU/Memory boards and COD RTU licenses that you purchase. The COD RTU licenses that you obtain are handled as a pool of available licenses.

When you activate a domain containing a COD CPU/Memory board or when a COD CPU/Memory board is connected to a domain through a dynamic reconfiguration (DR) operation, the following occurs automatically:

- The system checks the current installed COD RTU licenses.
- The system obtains a COD RTU license (from the license pool) for each CPU on the COD board.

The COD RTU licenses are allocated to the CPUs on a “first come, first serve” basis. However, you can allocate a specific quantity of RTU licenses to a particular domain by using the `setupplatform(1M)` command. For details, see [“To Enable Instant Access CPUs and Reserve Domain RTU Licenses” on page 130](#).

If there is an insufficient number of COD RTU licenses and a license cannot be allocated to a COD CPU, the COD CPU is not configured into the domain and is considered as unlicensed. A COD CPU is considered to be unused when it is assigned to a domain but the CPU is not active.

If a COD CPU/Memory board does not have sufficient COD RTU licenses for its COD CPUs, the system will fail the COD CPU/Memory board during the `setkeyswitch` operation. For additional details and examples, see [“Deconfigured and Unlicensed COD CPUs” on page 139](#).

When you remove a COD CPU/Memory board from a domain through a DR operation or when a domain containing a COD CPU/Memory board is shut down normally, the COD RTU licenses for the CPUs on those boards are released and added to the pool of available licenses.

You can use the `showcodusage` command to review COD usage and COD RTU license states. For details on `showcodusage` and other commands that provide COD information, see [“Monitoring COD Resources” on page 132](#).

Note – You can move COD boards between Sun Fire systems (Sun Fire 15K, 12K, 6800, 4810, 4800, and 3800 servers), but the associated license keys are tied to the original platform for which they were purchased and are non-transferable.

Instant Access CPUs

If you require COD CPU resources before you complete the COD RTU license purchasing process, you can temporarily enable a limited number of resources called *instant access CPUs* (also referred to as *headroom*). These instant access CPUs are available as long as there are unlicensed COD CPUs in the system. The maximum number of instant access resources available on Product Names is eight CPUs.

Instant access CPUs are disabled by default on Sun Fire high-end systems. If you want to use these resources, you activate them by using the `setupplatform(1M)` command. Warning messages are logged on the platform console, informing you that the number of instant access CPUs (headroom) used exceeds the number of COD licenses available. Once you obtain and add the COD RTU license keys for instant access CPUs to the COD license database, these warning messages will stop.

For details on activating instant access CPUs, see, [“To Enable Instant Access CPUs and Reserve Domain RTU Licenses” on page 130](#).

Instant Access CPUs as Hotspares

You can temporarily enable an available, instant access CPU to replace a failed non-COD CPU. In this case, the instant access CPU is considered as a *hotspare* (a spare CPU that can be used immediately to replace a failed non-COD CPU). However, once the failed non-COD CPU has been replaced, you must deactivate the instant access CPU (see [“To Enable Instant Access CPUs and Reserve Domain RTU Licenses” on page 130](#)). Contact your Sun sales representative or reseller to purchase a COD RTU license for the instant access CPU in use if you want to continue using it.

Resource Monitoring

Information about COD events, such as the activation of instant access CPUs (headroom) or license violations, is recorded in the platform log and can be viewed by using the `showlogs` command.

Other commands, such as the `showcodusage(1M)` command, provide information on COD components and COD configuration. For details on obtaining COD information and status, see [“Monitoring COD Resources” on page 132](#).

Getting Started with COD

Before you can use COD on Product Names, you must complete certain prerequisites. These tasks include the following:

- Installing the same version of the SMS software on both the main and spare system controller (SC).

For details on upgrading the software, refer to *the System Management Services (SMS) 1.4 Installation Guide*.

Note – SMS software versions before SMS 1.3 will not recognize COD CPU/Memory boards.

- Contacting your Sun sales representative or reseller and doing the following:
 - Signing the COD contract addendum, in addition to the standard purchasing agreement contract for your Product Name.
 - Purchasing COD CPU/Memory boards and arranging for their installation.
- Performing the COD RTU licensing process as described in [“To Obtain and Add a COD RTU License Key to the COD License Database”](#) on page 125.

Managing COD RTU Licenses

COD RTU license management involves the acquisition and addition of COD RTU licenses keys to the COD license database. You can also remove COD RTU licenses from the license database if needed.

▼ To Obtain and Add a COD RTU License Key to the COD License Database

1. **Contact your Sun sales representative or authorized Sun reseller to purchase a COD RTU license for each COD CPU to be enabled.**

Sun will send you a COD RTU License Certificate for each CPU license that you purchase. The COD RTU license sticker on the License Certificate contains a right-to-use serial number used to obtain a COD RTU license key.

2. **Contact the Sun License Center and provide the following information to obtain a COD RTU license key:**
 - The COD RTU serial number from the license sticker on the COD RTU License Certificate.
 - Chassis HostID, which uniquely identifies the platform.

You can obtain the Chassis HostID by running the command
`showplatform -p cod` as platform administrator.

For instructions on contacting the Sun License Center, refer to the COD RTU License Certificate that you received or check the Sun License Center web site:

`http://www.sun.com/licensing`

The Sun License Center will send you an email message containing the RTU license key for the COD resources that you purchased.

3. **Add the license key to the COD license database by using the `addcodlicense (1M)` command. In an SC window, log in as a platform administrator and type:**

```
sc0:sms-user:> addcodlicense license-signature
```

where *license-signature* is the complete COD RTU license key assigned by the Sun License Center. You can copy the license key string that you receive from the Sun License Center.

4. **Verify that the specified license key was added to the COD license database by running the `showcodlicense -r` command (see [“To Review COD License Information” on page 127](#)).**

The COD RTU license key that you added should be listed in the `showcodlicense(1M)` command output.

▼ To Delete a COD License Key From the COD License Database

1. **In an SC window, log in as a platform administrator and type:**

```
sc0:sms-user:> deletecodlicense license-signature
```

where :

license-signature is the complete COD RTU license key to be removed from the COD license database.

The system verifies that the license removal will not cause a COD RTU license violation, which occurs when there is an insufficient number of COD licenses for the number of COD resources in use. If the deletion will cause a COD RTU license violation, the SC will not delete the license key.

Note – You can force the removal of the license key by specifying the `-f` option with the `deletecodlicense(1M)` command. However, be aware that the license key removal could cause a license violation or an over commitment of RTU license reservations. An RTU license over commitment occurs when there are more RTU domain reservations than RTU licenses installed in the system. For additional details, refer to the `deletecodlicense(1M)` command description in the *System Management Services (SMS) 1.4 Reference Manual*.

2. Verify that the license key was deleted from the COD license database by running the `showcodlicense -r` command, described in the next procedure.

The deleted license key should not be listed in the `showcodlicense` output.

▼ To Review COD License Information

1. In an SC window, log in as a platform administrator and type one of the following to display COD license information:
 - To view license data in an interpreted format, type:

```
sc0:sms-user:> showcodlicense
```

For example:

```
sc0:sms-user:> showcodlicense
```

Description	Lic	Expiration	Count	Status	Cls	Tier	
	Ver					Num	Req
PROC	01	NONE	16	GOOD	1	1	0

TABLE 6-1 describes the COD license information in the `showcodlicense` output.

TABLE 6-1 COD License Information

Item	Description
Description	Type of resource (processor)
Lic Ver	Version number of the license
Expiration	None. Not supported (no expiration date)
Count	Number of RTU licenses granted for the given resource

TABLE 6-1 COD License Information (*Continued*)

Item	Description
Status	One of the following states: <ul style="list-style-type: none">• GOOD – Indicates the resource license is valid• EXPIRED – Indicates the resource license is no longer valid
Cls	Not applicable.
Tier Num	Not applicable.
Req	Not applicable.

- To view license data in raw license key format, type:

```
sc0:sms-user:> showcodlicense -r
```

The license key signatures for COD resources are displayed. For example:

```
sc0:sms-user:> showcodlicense -r
01:5014936C37048:45135285:0201000000:8:00000000:0000000000000000000000
```

Note – The COD RTU license key listed above is provided as an example and is not a valid license key.

For details on the `showcodlicense(1M)` command, refer to the command description in the *System Management Services (SMS) 1.4 Reference Manual*.

Activating COD Resources

To activate instant access CPUs and allocate COD RTU licenses to specific domains, use the `setupplatform` command. [TABLE 6-2](#) describes the various `setupplatform` command options that can be used to configure COD resources

TABLE 6-2 setupplatform Command Options for COD Resource Configuration

Use setupplatform Command Options	To...
setupplatform -p cod	Enable or disable instant access CPUs (headroom) and allocate domain COD RTU licenses
setupplatform -p cod headroom-number	Enable or disable instant access CPUs (headroom)
setupplatform -p cod -d domainid RTU-number	Reserve a specific quantity of COD RTU licenses for a particular domain

For details on the setupplatform command options, refer to the command description in the *System Management Services (SMS) 1.4 Reference Manual*.

▼ To Enable Instant Access CPUs and Reserve Domain RTU Licenses

1. In an SC window, log in as a platform administrator and type:

```
sc0:sms-user:> setupplatform -p cod
```

You are prompted to enter the COD parameters (headroom quantity and domain RTU information). For example:

```
sc0:sms-user:> setupplatform -p cod
PROC RTUs installed: 12
PROC Headroom Quantity (0 to disable, 8 MAX) [0]:0
PROC RTUs reserved for domain A (12 MAX) [0]: 4
PROC RTUs reserved for domain B (8 MAX) [2]: 4
PROC RTUs reserved for domain C (4 MAX) [0]: 0
PROC RTUs reserved for domain D (4 MAX) [0]:?
PROC RTUs reserved for domain E (4 MAX) [0]?
PROC RTUs reserved for domain G (4 MAX) [0]?
PROC RTUs reserved for domain H (4 MAX) [0]?
PROC RTUs reserved for domain I (4 MAX) [0]?
PROC RTUs reserved for domain J (4 MAX) [0]?
PROC RTUs reserved for domain K (4 MAX) [0]?
PROC RTUs reserved for domain L (4 MAX) [0]?
PROC RTUs reserved for domain M (4 MAX) [0]?
PROC RTUs reserved for domain N (4 MAX) [0]?
PROC RTUs reserved for domain O (4 MAX) [0]?
PROC RTUs reserved for domain P (4 MAX) [0]?
PROC RTUs reserved for domain Q (4 MAX) [0]?
PROC RTUs reserved for domain R (4 MAX) [0]?
```

Note the following about the prompts displayed:

- Instant access CPU (headroom) quantity

The text in parenthesis indicates the maximum number of instant access CPUs (headroom) allowed. The value inside the brackets is the number of instant access CPUs currently configured.

To disable the instant access CPU (headroom) feature, type 0. You can disable the headroom quantity only when there are no instant access CPUs in use.

- Domain reservations

The text in parenthesis indicates the maximum number of RTU licenses that can be reserved for the domain. The value inside the brackets is the number of RTU licenses currently allocated to the domain.

2. Verify the COD resource configuration by running the `showplatform(1M)` command:

```
sc0:sms-user:> showplatform -p cod
```

For example:

```
sc0:sms-user:> showplatform -p cod

COD:
====
Chassis HostID : 5014936C37048
PROC RTUs installed: 8
PROC Headroom Quantity: 0
PROC RTUs reserved for domain A : 4
PROC RTUs reserved for domain B : 0
PROC RTUs reserved for domain C : 0
PROC RTUs reserved for domain D : 0
PROC RTUs reserved for domain E : 0
PROC RTUs reserved for domain F : 0
PROC RTUs reserved for domain G : 0
PROC RTUs reserved for domain H : 0
PROC RTUs reserved for domain I : 0
PROC RTUs reserved for domain J : 0
PROC RTUs reserved for domain K : 0
PROC RTUs reserved for domain L : 0
PROC RTUs reserved for domain M : 0
PROC RTUs reserved for domain N : 0
PROC RTUs reserved for domain O : 0
PROC RTUs reserved for domain P : 0
PROC RTUs reserved for domain Q : 0
PROC RTUs reserved for domain R : 0
```

Note – The Chassis HostID is used for COD licensing purposes. If the Chassis HostID is listed as UNKNOWN, you must power on the centerplane support boards to obtain the Chassis HostID. In this case, allow up to one minute before rerunning the `showplatform` command to display the Chassis HostID.

Monitoring COD Resources

This section describes various ways to track COD resource use and obtain COD information.

COD CPU/Memory Boards

You can determine which CPU/Memory boards in your system are COD boards by using the `showboards(1M)` command.

▼ To Identify COD CPU/Memory Boards

1. In an SC window, log in as platform administrator and type:

```
sc0:sms-user:> showboards -v
```

The information displayed shows board assignments and test status. COD CPU boards are identified as CPU (COD).

For example:

```
sc0:sms-user:> showboards -v
Location      Pwr      Type of Board  Board Status  Test Status  Domain
-----
SC0           On       SC             Main          -            -
SC1           On       SC             Spare         -            -
PS0           On       PS             -            -            -
PS1           On       PS             -            -            -
.
.
.
SB0           Off      CPU            Available     Unknown     Isolated
SB1           -        Empty Slot     Available     -           Isolated
SB2           Off      CPU            Available     Unknown     Isolated
SB3           -        Empty Slot     Available     -           Isolated
SB4           On       CPU (COD)     Assigned     Unknown     A
SB5           -        Empty Slot     Available     -           Isolated
SB6           On       CPU (COD)     Active        Passed      B
SB7           -        Empty Slot     Available     -           Isolated
SB8           -        Empty Slot     Available     -           Isolated
SB9           -        Empty Slot     Available     -           Isolated
SB10          -        Empty Slot     Available     -           Isolated
SB11          -        Empty Slot     Available     -           Isolated
SB12          Off      CPU (COD)     Assigned     Unknown     C
.
.
.
```

COD Resource Usage

To obtain information on how COD resources are used in your system, use the `showcodusage(1M)` command.

▼ To View COD Usage By Resource

1. In an SC window, log in as a platform administrator and type:

```
sc0:sms-user:> showcodusage -p resource
```

For example:

```
sc0:sms-user:> showcodusage -p resource
Resource:
=====
Resource      In Use   Installed  Licensed  Status
-----
PROC          4        12         12        OK: 8 available
```

TABLE 6-1 describes the COD resource information displayed by the showcodusage(1M) command.

TABLE 6-3 showcodusage Resource Information

Item	Description
Resource	The COD resource (processor)
In Use	The number of COD CPUs currently used in the system
Installed	The number of COD CPUs installed in the system
Licensed	The number of COD RTU licenses installed
Status	One of the following COD states: <ul style="list-style-type: none">• OK – Indicates there are sufficient licenses for the COD CPUs in use and specifies the number of remaining COD resources available and the number of any instant access CPUs (headroom) available• HEADROOM – The number of instant access CPUs in use• VIOLATION – Indicates a license violation exists. Specifies the number of COD CPUs in use that exceeds the number of COD RTU licenses available. This situation can occur when you force the deletion of a COD license key from the COD license database, but the COD CPU associated with that license key is still in use.

▼ To View COD Usage by Domain

1. In an SC window, log in as a platform or domain administrator and type:

```
sc0:sms-user:> showcodusage -p domains -v
```

The output includes the status of CPUs for all domains. For example:

```

sc0:sms-user:> showcodusage -p domains -v
Domains:
=====
Domain/Resource  In Use  Installed  Reserved  Status
-----
A - PROC         0        4         4
   SB4 - PROC    0        4
   SB4/P0                Unused
   SB4/P1                Unused
   SB4/P2                Unused
   SB4/P3                Unused
B - PROC         4        4         4
   SB6 - PROC    4        4
   SB6/P0                Licensed
   SB6/P1                Licensed
   SB6/P2                Licensed
   SB6/P3                Licensed
C - PROC         0        4         0
   SB12 - PROC   0        4
   SB12/P0                Unused
   SB12/P1                Unused
   SB12/P2                Unused
   SB12/P3                Unused
.
.
.

```

TABLE 6-4 describes the COD resource information displayed by domain.

TABLE 6-4 showcodusage Domain Information

Item	Description
Domain/Resource	The COD resource (processor) for each domain. An unused processor is a COD CPU that has not yet been assigned to a domain.
In Use	The number of COD CPUs currently used in the domain
Installed	The number of COD CPUs installed in the domain
Reserved	The number of COD RTU licenses allocated to the domain
Status	One of the following CPU states: <ul style="list-style-type: none"> • Licensed – The COD CPU has a COD RTU license. • Unused -The COD CPU is not in use. • Unlicensed - The COD CPU could not obtain a COD RTU license and is not in use.

▼ To View COD Usage by Resource and Domain

1. In an SC window, log in as a platform administrator and type:

```
sc0:sms-user:> showcodusage -v
```

The information displayed contains usage information by both resource and domain.

For example:

```
sc0:sms-user:> showcodusage -v
Resource:
=====
Resource   In Use   Installed   Licensed   Status
-----
PROC              4           4           16   OK: 12 available
Domains:
=====
Domain/Resource   In Use   Installed   Reserved   Status
-----
A - PROC              0           0           0
B - PROC              0           0           0
   SB6 - PROC         0           0
   SB6/P0                          Unused
   SB6/P1                          Unused
   SB6/P2                          Unused
   SB6/P3                          Unused
C - PROC              0           0           0
   SB12 - PROC        0           0
   SB12/P0                          Unused
   SB12/P1                          Unused
   SB12/P2                          Unused
   SB12/P3                          Unused
D - PROC              4           4           0
   SB4 - PROC         4           4
   SB4/P0                          Licensed
   SB4/P1                          Licensed
   SB4/P2                          Licensed
   SB4/P3                          Licensed
   SB16 - PROC        4           4
   SB16/P0                          Unused
   SB16/P1                          Unused
   SB16/P2                          Unused
   SB16/P3                          Unused
E - PROC              0           0           0
F - PROC              0           0           0
G - PROC              0           0           0
.
.
.
R - PROC              0           0           0
Unused - PROC        0           0           12
```

Deconfigured and Unlicensed COD CPUs

When you activate a domain that uses COD CPU/Memory boards, any COD CPUs that cannot obtain a COD RTU license are identified as deconfigured or unlicensed. You can determine which COD CPUs are deconfigured or unlicensed by reviewing the following items:

- Message output for a `setkeyswitch on` operation

Any COD CPUs that did not acquire a COD RTU license are identified as deconfigured. If all the COD CPUs on a COD CPU/Memory board are deconfigured, the `setkeyswitch on` operation will fail the COD CPU/Memory board, and the `setkeyswitch on` operation also fails, as the next example shows:

```
sc0:sms-user:> setkeyswitch -d A on
.
.
.
Acquiring licenses for all good processors...
Proc SB03/P0    deconfigured: no license available.
Proc SB03/P2    deconfigured: no license available.
Proc SB03/P3    deconfigured: no license available.
Proc SB03/P1    deconfigured: no license available.
No minimum system left after Check CPU licenses (for COD)! Bailing out!
.
.
.
Deconfigure Slot0: 00008
Deconfigure EXB:   00008
POST (level=16, verbose=40, -H3.0) execution time 3:08
# SMI Sun Fire 15K POST log closed Fri Jul 26 15:15:53 2002
```

- `showcodusage(1M)` command output

To obtain the status of COD CPUs for a domain, see [“To View COD Usage by Domain” on page 134](#). The Unlicensed status indicates that a COD RTU license could not be obtained for the COD CPU and that the CPU is not being used by the domain.

Other COD Information

[TABLE 6-5](#) summarizes the COD configuration and event information that you can obtain through other system controller commands. For further details on these commands, refer to their descriptions in the *System Management Services (SMS) 1.4 Reference Manual*.

TABLE 6-5 Obtaining COD Component, Configuration, and Event Information

To...	Use This Command
Display information about COD events, such as license violations or headroom activation, that are logged on the platform console	<code>showlogs</code>
Display the current COD resource configuration: <ul style="list-style-type: none">• Number of instant access CPUs (headroom) in use• Domain RTU license reservations• Chassis HostID	<code>showplatform -p cod</code>

Domain Control

This chapter addresses the functions that provide control over domain software as well as server hardware. Control functions are invoked at the discretion of an administrator. They are also useful to SMS for providing automatic system recovery (ASR).

Domain control functionality provides control over the software running on a domain. It includes those functions that allow a domain to be booted and interrupted. Only the domain administrator can invoke the domain control functions.

This chapter includes the following sections:

- [Domain Boot](#)
- [Hardware Control](#)

Domain Boot

This section describes the various aspects of booting the Solaris operating environment in a domain running SMS software.

`setkeyswitch(1M)` is responsible for initiating and sequencing a domain boot. It powers on the domain hardware as required and invokes POST to test and configure the hardware in the logical domain into a Sun Fire high-end system's physical hardware domain. It downloads and initiates OpenBoot PROM as required to boot the Solaris operating environment on the domain.

Only domains that have their virtual keyswitch set appropriately are subject to boot control. See [“Virtual Keyswitch” on page 91](#).

OpenBoot PROM boot parameters are stored in the domain's virtual NVRAM. `osd(1M)` provides those parameter values to OpenBoot PROM, which adapts the domain boot as indicated.

Certain parameters, in particular those that may not be adjustable from OpenBoot PROM itself when a domain is failing to boot, can be set by `setobpparams(1M)` so that they take effect at the next boot attempt.

Keyswitch On

The domain keyswitch control ([“Virtual Keyswitch” on page 91](#)) manually initiates domain boot.

`setkeyswitch` boots a properly configured domain when its keyswitch control is moved from the `off` or `standby` position to one of the `on` positions. This takes approximately 20 minutes.

`setobpparams(1M)` provides a method by which a manually initiated (keyswitch control) domain boot sequence can be stopped in OpenBoot PROM. For more information see [“Setting the OpenBoot PROM Variables” on page 95](#) and refer to the `setobpparams` man page.

Power

SMS boots all properly configured domains when the Sun Fire high-end system chassis is powered on using the `poweron(1M)` command. SMS shuts down all properly configured domains when the chassis is powered off using the `poweroff` command.

SMS checks the power state of components to determine if they are on or off and enables or disables console bus ports (where appropriate) when boards are powered on/off. `poweron` checks to see if a component is physically present. `poweroff` unconfigures DCUs from the expander and changes the expander from `split-slot` to `nonsplit-slot` when appropriate. `poweroff` unconfigures the expander from the centerplane when the expander is powered off and checks for voltage reading tolerances to help determine if the board is on or off.

The following components can be power controlled using the `poweron` and `poweroff` commands.

- Bulk power supply
- Fan tray
- Centerplane support board
- Expander board
- CPU/Memory board
- Standard PCI board
- Hot-pluggable PCI and PCI+ assemblies
- MaxCPU board
- wPCI board

- System controller (spare only; `poweroff` only. `resetsc` is used to power on the spare.)

▼ To Power System Boards On and Off From the Command Line

Platform administrators are allowed to power control the entire system and can execute these commands without a *location* option. Domain administrators can power control any system board assigned to their domain(s). Users with only domain privileges must supply the *location* option.

1. To power on a system component, type:

```
sc0:sms-user:> poweron location
```

where

location The location of the system component you wish to power on and, if you are a domain administrator, for which you have privileges.

For more information, refer to the `poweron(1M)` man page.

2. To power off a system component, type:

```
sc0:sms-user:> poweroff location
```

where:

location The location of the system component you wish to power off and, if you are a domain administrator, for which you have privileges.

Enter `y` or `n` after the warning message:

```
!!!WARNING!!!WARNING!!!WARNING!!!WARNING!!!WARNING!!!  
!!!WARNING!!!WARNING!!!WARNING!!!WARNING!!!WARNING!!!  
  
This will trip the breakers on PS at PS5, which must be turned on  
manually!  
  
Are you sure you want to continue to power off this component?  
(yes/no)? y
```

Note – If you are powering off a component to replace it, use the `poweroff(1M)` command. Do not use the breakers to power off the component; this can cause a Domain Stop.

For more information, refer to the `poweroff(1M)` man page.

If you try to power off the system while any domain is actively running the operating system, the command will fail and display a message in the message panel of the window. In that case, issuing a `setkeyswitch domain_id standby` command for the active domain(s) will gracefully shut down the processors. Then, you can reissue the command to power off.

If the platform loses power due to a power outage, `pcd` records and saves the last state of each domain before power was lost.

▼ To Recover From Power Failure

If you lose power only to the SC, switch on the power to the SC. Sun Fire high-end system domains are not affected by the loss of power to one SC. If you lose power to both the SC and the domains, use the following procedure to recover from the power failure. For switch locations refer to the *Sun Fire 15K/12K System Site Planning Guide*.

Note – Losing power to both SCs without shutting down SMS, will crash the domains.

1. **Manually switch off the bulk power supplies on the Sun Fire high-end system as well as the power switch on the SC.**

This prevents power surge problems that can occur when power is restored.

2. **After power is restored, manually switch on the bulk power supplies on the Sun Fire high-end system.**

3. **Manually switch on the SC power.**

This boots the SC and starts the SMS daemons. Check your SC platform message file for completion of the SMS daemons.

4. **Wait for the recovery process to complete.**

Any domain that was powered on and running the Solaris operating environment returns to the operating environment run state. Domains at OpenBoot PROM eventually return to an OpenBoot PROM run state.

The recovery process must finish before any SMS operation is performed. You can monitor the domain message files to determine when the recovery process has completed.

Domain-Requested

SMS reboots domains upon request from the domain software (Solaris software or `dsmd`). The domain software requests reboot services in the following situations.

- Upon execution of a user reboot request, for example, Solaris `reboot(1M)` or the OpenBoot PROM boot command, `reset-all`.
- Upon Solaris software panic.
- Upon trapping the CPU-detected `RED_mode` or Watchdog Reset conditions.

Automatic System Recovery (ASR)

Automatic system recovery (ASR) consists of those procedures that restore the system to running all properly configured domains after one or more domains have been rendered inactive due to software or hardware failures or due to unacceptable environmental conditions.

SMS software supports a software-initiated reboot request as part of ASR. Every domain that crashed is automatically rebooted by `dsmd`.

Situations that require ASR are domain boots requested by domain software upon detecting failures that crash the domain (for example, panic).

There are other situations, such as detection of domain software hangs as described in [“Solaris Software Hang Events” on page 208](#), where SMS initiates a domain boot as part of the recovery process.

`dsmd` ignores the OpenBoot PROM parameter, `auto-boot?`, which on systems without a service processor can prevent the system from automatically rebooting in power-on-reset situations. `dsmd` does *not* ignore keyswitch control. If the keyswitch is set to `off` or `standby`, the keyswitch setting will be honored in determining whether a domain is subject to ASR reboot actions.

Fast Boot

In general a fast domain reboot is possible in situations where:

- No serious error has been attributed to hardware since the last boot.
- No failures have occurred which would cause SMS to question the reliability of the existing set of domain resources.

Because SMS is responsible for monitoring the hardware, detecting, and responding to errors, SMS decides whether or not to request a fast reboot based upon its record of hardware errors since the last boot.

Because POST controls the hardware configuration based upon a number of inputs including, but not limited to, the blacklist data, POST decides whether or not the hardware configuration has changed so as to preclude a fast reboot. If system management has requested a fast reboot, POST will verify that the hardware configuration implied by its current inputs matches the hardware configuration used for the last boot; if it does not, POST will fail the fast-POST operation. The system management software is prepared to recover from this type of POST failure by requesting a full-test (slow) domain boot.

Sun Fire high-end system management software minimizes the elapsed time taken by the part of the domain boot process that it can control.

Domain Abort/Reset

Certain error conditions can occur in a domain that require aborting the domain software or issuing a reset to the domain software or hardware. This section describes the domain abort/reset functions that are provided by `dsmd`.

`dsmd` provides a software-initiated mechanism to abort a domain Solaris OS, requesting that it panic to take a core image. No user intervention is needed.

SMS provides the `reset(1M)` command to allow the user to abort the domain software and issue a reset to the domain hardware.

Control is passed to OpenBoot PROM after the `reset` command is issued. In the case of a user-interface-issued `reset` command, OpenBoot PROM uses its default configuration to determine whether the domain is booted to the Solaris environment. In the case of a `dsmd`-issued `reset` command, OpenBoot PROM provides parameters that force the domain to be booted to the Solaris operating environment.

`reset` normally sends a signal to all CPU ports of a specified domain. This is a hard reset and clears the hardware to a clean state. Using the `-x` option, however `reset` can send an XIR signal to the processors in a specified domain. This is done in software and is considered a soft reset. An error message is given if the virtual key switch is in the secure position. An optional `Are you sure?` prompt is given by default. For example:

```
sc0:sms-user:> reset -d C
Do you want to send RESET to domain C? [y|n]:y
RESET to processor 4.1.0 initiated.
RESET to processor 4.1.1 initiated.
RESET initiated to all processors for domain: C
```

For more information refer to the `reset` man page.

For information on resetting the main or spare SC see [“SC Reset and Reboot” on page 155](#).

SMS software illuminates or darkens the indicator LEDs on LED-equipped hot-pluggable units (HPU) as necessary to reflect the correct state when the HPU is given a power-on reset.

Hardware Control

Hardware control functions are those that configure and control the platform hardware. Some functions are invoked on the domain.

Power-On Self-Test (POST)

System management services software invokes POST in two contexts.

1. At domain boot-time, POST is invoked to test and configure all functional hardware available to the domain.

POST eliminates all hardware components that fail self-test and attempts to build a bootable domain from the functionally working hardware.

POST provides extensive diagnostics to report hardware test results to help analyze failures. POST may be requested only to verify a domain configuration, and not test it, in situations where the domain is being rebooted with no indications that a hardware failure was the cause.

2. Before a DR operation to add a system board to a domain begins, POST is invoked to test and configure the system board components.

If POST indicates that the candidate system board is functional, the DR operation can safely incorporate the system board into the physical (hardware) domain.

Although POST is generally invoked automatically, there are user visible interfaces that affect automatic POST invocations:

- The level of diagnostics testing that is performed by POST is increased from a nominal to maximum level using domain keyswitch control, `setkeyswitch(1M)` as described in [“Virtual Keyswitch” on page 91](#).
- You can add or remove components that you want POST to exclude from the hardware configuration by using blacklist files. These editable files are described in [“Blacklist Editing” on page 148](#).

This gives you finer-grained control over the hardware components that are used in a domain than is allowed by the standard domain configuration interfaces that operate on DCUs, such as system boards.

- `setkeyswitch` invokes POST to test and configure a domain. Nominal and maximum diagnostic test level settings are provided for use in booting the domain.
- `addboard` and `moveboard` invoke POST to test and configure a system board in support of a DR operation to add that board to a running Solaris domain.
- LED-equipped FRUs with components that fail POST will have the fault LED illuminated on the FRU.

Blacklist Editing

SMS supports three blacklists: one for the platform, one for the domains; and the internal automatic system recovery (ASR) blacklist.

Platform and Domain Blacklisting

The editable blacklist files specify that certain hardware resources are to be considered unusable by POST. They will not be probed for, tested, or configured in the domain interconnect.

Usually these blacklist files are empty, and are not required to be present.

Blacklist capability in this context is used for resource management purposes.

Blacklisting temporarily limits the system configuration to less than all the hardware present. This has several applications, such as benchmarking, limiting memory use to make DR detach of the board faster, and varying the configuration for troubleshooting.

Sun Fire high-end system POST supports two editable canonical blacklist files, one for the platform, one for the domain, located in:

```
/etc/opt/SUNWSMS/config/platform/blacklist
```

and

```
/etc/opt/SUNWSMS/config/domain_id/blacklist
```

The two files are considered logically concatenated.

Note – The blacklist file specifies resources based on physical location. If the component is physically moved, any corresponding blacklist entries must be changed accordingly.

Blacklist specifies blacklisted components logically, for example, by specifying their position and the blacklist remains on the component position through a hot-swap operation rather than following a specific component.

▼ To Blacklist a Component

1. Log in to the SC.

You must have platform administrator, or domain administrator, or configurator privileges to edit the blacklist files.

2. Type:

```
sc0:sms-user:> disablecomponent [-d domain_indicator] location
```

where:

-d domain_indicator Specifies the domain using one of the following:
domain_id – ID for a domain. Valid *domain_ids* are A–R and are not case sensitive.
domain_tag – Name assigned to a domain using `addtag(1M)`.

location List of component locations comprised of:
board_loc/proc/bank/logical_bank
board_loc/proc/bank/all_dimms_on_that_bank
board_loc/proc/bank/all_banks_on_that_proc
board_loc/proc/bank/all_banks_on_that_board
board_loc/proc
board_loc/cassette
board_loc/bus
board_loc/paroli_link

If no *domain_indicator* is specified, the platform blacklist is edited. All component locations are separated by forward slashes. The *location* forms are optional and are used to specify particular components on boards in specific locations.

Multiple *location* arguments are permitted separated by a space.

Location	Valid Form for Sun Fire 15K	Valid Form for Sun Fire 12K
<i>board_loc</i>	SB(0...17) IO(0...17) CS(0 1) EX(0...17)	SB(0...8) IO(0...8) CS(0 1) EX(0...8)
Processor/Processor Pair (<i>proc</i>)	P(0...3) PP(0 1)	P(0...3) PP(0 1)
<i>bank</i>	B	B
<i>logical_bank</i>	L(0 1)	L(0 1)
<i>all_dimms_on_that_bank</i>	D	D
<i>all_banks_on_that_proc</i>	B	B
<i>all_banks_on_that_board</i>	B	B
<i>HsPCI cassette</i>	C(3 5)V(0 1)	C(3 5)V(0 1)
<i>HsPCI+ cassette</i>	C3V(0 1 2) and C5V0	C3V(0 1 2) and C5V0
<i>bus</i>	ABUS DBUS RBUS (0 1)	ABUS DBUS RBUS (0 1)
<i>paroli_link</i>	PAR(0 1)	PAR(0 1)

Processor locations indicate single processors or processor pairs. There are four possible processors on a CPU/Memory board. Processor pairs on that board are procs 0 and 1, and procs 2 and 3.

Note – If you blacklist a single CPU/mem processor in a processor pair, neither processor is used.

The MaxCPU has two processors, procs 0 and 1, and only one proc pair (PP0). `disablecomponent` exits and displays an error message if you use PP1 as a location for this board.

The HsPCI and HsPCI+ assemblies contain hot-swappable cassettes.

There are three bus locations: address, data, and response.

Note – Do not use the `disablecomponents` command to disable center plane support boards or a bus on the system controller.

▼ To Remove a Component From the Blacklist

1. Log in to the SC.

2. Type:

```
sc0:sms-user:> enablecomponent [-d domain_indicator] location
```

where:

-d domain_indicator Specifies the domain using one of the following:
domain_id – ID for a domain. Valid *domain_ids* are A–R and are not case sensitive.

domain_tag – Name assigned to a domain using `addtag(1M)`.

location List of component locations comprised of:

board_loc/proc/bank/logical_bank,

board_loc/proc/bank/all_dimms_on_that_bank

board_loc/proc/bank/all_banks_on_that_proc

board_loc/proc/bank/all_banks_on_that_board

board_loc/proc

board_loc/cassette

board_loc/bus

board_loc/paroli_link

If no *domain_indicator* is specified the platform blacklist is edited. All component locations are separated by forward slashes. The *location* forms are optional and are used to specify particular components on boards in specific locations.

Multiple *location* arguments are permitted separated by a space.

Location	Valid Form for Sun Fire 15K	Valid Form for Sun Fire 12K
<i>board_loc</i>	SB(0...17) IO(0...17) CS(0 1) EX(0...17)	SB(0...8) IO(0...8) CS(0 1) EX(0...8)
Processor/Processor Pair (<i>proc</i>)	P(0...3) PP(0 1)	P(0...3) PP(0 1)
<i>bank</i>	B	B
<i>logical_bank</i>	L(0 1)	L(0 1)
<i>all_dimms_on_that_bank</i>	D	D
<i>all_banks_on_that_proc</i>	B	B
<i>all_banks_on_that_board</i>	B	B
<i>HsPCI cassette</i>	C(3 5)V(0 1)	C(3 5)V(0 1)
<i>HsPCI+ cassette</i>	C3V(0 1 2) and C5V0	C3V(0 1 2) and C5V0
<i>bus</i>	ABUS DBUS RBUS (0 1)	ABUS DBUS RBUS (0 1)
<i>paroli_link</i>	PAR(0 1)	PAR(0 1)

Processor locations indicate single processors or processor pairs. There are four possible processors on a CPU/Mem board. Processor pairs on that board are: procs 0 and 1, and procs 2 and 3.

Note – If you blacklist a single CPU/mem processor in a processor pair, neither processor is used.

The MaxCPU has two processors,; procs 0 and 1, and only one proc pair (PP0). `disablecomponent` exits and displays an error message if you use PP1 as a location for this board.

The HsPCI and HsPCI+ assemblies contain hot-swappable cassettes.

There are three bus locations: address, data and response.

For more information, refer to the `enablecomponent(1M)` and `disablecomponent(1M)` man pages.

ASR Blacklist

Hardware that has failed repeatedly, perhaps intermittently, needs to be excluded from subsequent domain configurations for many reasons. It may be some time before the component can be physically replaced. The failed component might be a

subcomponent such as one processor on a CPU board. You do not want to lose the services of the rest of the component by powering it down until it can be replaced. If the hardware is broken, you do not want to waste time having POST discover that every time it runs. If the failure is intermittent, you do not want POST to pass it, only to have it fail when the OE is running.

To this end, `esmd` creates and edits a separate ASR blacklist file. Components that have been powered off due to environmental conditions are automatically listed and excluded from POST. `poweron`, `setkeyswitch`, `addboard`, and `moveboard` query the ASR blacklist for components to exclude. Each of these commands except `poweron` display a warning message. `poweron` instead asks whether you would like to continue or abort powering up the component. For more information refer to the `enablecomponent(1M)`, `disablecomponent(1M)`, and `showcomponent(1M)` man pages.

Power Control

The main SC has power control over the following components in the Sun Fire high-end system rack:

- Sun Fire high-end system boards
- HsPCI adaptor slots on the Sun Fire high-end system HsPCI I/O assembly
- HsPCI+ adaptor slots on the Sun Fire high-end system HsPCI+ I/O assembly
- CPU pairs
- System controllers (power off only)
- Centerplane support boards
- wPCI boards
- Expander boards
- 48V power supplies
- AC bulk power modules
- Fan trays

See [“HPU LEDs” on page 156](#) for a description of power control in the Sun Fire high-end system I/O racks.

SMS supports the domain Solaris command interface (`cfgadm(1M)`) by providing the `rcfgadm(1M)` command to request power on or off of the HPCI adaptor slots in a Sun Fire high-end system HsPCI I/O assembly. For more information refer to the `rcfgadm` man page.

The keyswitch control interface, `setkeyswitch`, as described in [“Virtual Keyswitch” on page 91](#) allows the user to power on or off the hardware assigned to a domain.

All power operations are logged by the power control software.

The power control software conforms to all hardware requirements for powering on or off components. For example, SMS checks for adequate power available before powering on components. The power control interfaces will not perform a user-specified power on or power off operation if it violates a hardware requirement. Power operations that are performed contrary to hardware requirements or hardware recommended procedures are noted in the message logs.

By default, the power control software refuses to perform power operations that will affect running software. The power control user interfaces include methods to override this default behavior and forcibly complete the power operation at the cost of crashing running software. The use of these forcible overrides on power operations are noted in the message logs.

As described in [“HPU LEDs” on page 156](#), SMS illuminates or darkens the indicator LEDs on LED-equipped HPUs, as necessary, to reflect the correct state when the HPU is powered on or off.

Fan Control

`esmd` provides the fan speed control for Sun Fire high-end system fans. In general, fan speeds are set to the lowest speed that provides adequate cooling so as to minimize noise levels.

Hot-Swap

Hot-swap refers to the ability to physically insert or remove a board from a powered-on platform, actively running one or more domains without affecting those domains. During a hot-swap operation, the board is isolated from all domains.

The term for a hardware component that may be hot-swapped is hot-pluggable unit (HPU). The `OK to remove` indicator LED on an HPU is illuminated when it can be safely unplugged; see [“HPU LEDs” on page 156](#) for more information about the `OK to remove` LEDs. Board presence registers indicate whether an HPU is present or absent and sense an HPU plug or unplug.

The Sun Fire high-end system HsPCI and HsPCI+ I/O assemblies are equipped with `OK to remove` indicator LEDs associated with the slots into which HsPCI and HsPCI+ I/O assemblies are plugged. Each slot is equipped with a hot-plug controller that controls power to the slot and can detect presence of an adaptor in the slot. However, unlike SMS support for other Sun Fire high-end system HPUs, the software that controls hot-swap for the HsPCI and HsPCI+ I/O assemblies is part of the Solaris environment on the domain.

SMS allows you to power on and off the adaptor slots.

SMS software provides software interfaces, invocable from the domain, to control hardware devices associated with the adaptor slots on I/O boards.

For the purposes of the remaining hot-swap discussion in this section, HPUs do not include hot-swappable I/O adaptors.

SMS software provides support as necessary to allow hot-swap servicing of all HPUs in the Sun Fire high-end system rack.

Once an HPU is isolated from all domains the only software support required for hot-swap is power-off control.

Dynamic reconfiguration (DR) is used to isolate DCUs (system boards) from a domain by DR detaching the DCU.

Hot-Unplug

When an HPU is unplugged, the presence indicator for the HPU detects its absence resulting in a change in hardware configuration status as described in [“Hardware Configuration” on page 174](#).

The expected mode of user interaction during hot-unplug is as follows:

Go directly to the HPU you wish to unplug. If the HPU indicator LEDs show that it is *notOK* to *remove*, request that the HPU be powered off using the `poweroff` command. If the power-off function discovers that the HPU is in use by a domain, the power-off function will fail, indicating that you first must use DR to remove the HPU from active use. Refer to the *System Management Services (SMS) 1.4 Dynamic Reconfiguration User Guide* for more information.

Hot-Plug

The presence of a newly inserted HPU will be detected and reported as a change in hardware configuration status as described in [“Hardware Configuration” on page 174](#).

SC Reset and Reboot

The SC supports software-initiated resets for the main and spare, providing the same functionality as external reset buttons on the system controller. Typically, an SC might be reset after failover. It is possible for the main SC software to reset the spare SC, if present, and vice versa. An SC cannot reset itself.

▼ To Reset the Main or Spare SC

`resetsc` (1M) sends a reset signal to the other SC. If the other SC is not present, `resetsc` exits with an error.

1. Type:

```
sc0:sms-user:> resetsc
"About to reset other SC. Are you sure you want to continue?" (y
or [n])? y
```

For more information, refer to the `resetsc` man page.

HPU LEDs

The LEDs reflect the status of the hot-pluggable units (HPU). LEDs come in groups of three:

- The operating indicator LED is illuminated when power is on.
- The OK to remove LED is illuminated when an HPU can be unplugged.
- The fault LED is illuminated when a hardware fault has been discovered in an HPU.

This section describes the LED control policies that are followed by SMS software for the HPUs.

Except for the system controllers, all Sun Fire high-end system HPUs are powered on and tested under control of the SMS software that runs on the main system controller.

To a certain extent, the design of the LEDs, especially their initial state upon power-on-reset, is based upon the assumption that POST is automatically initiated at power-on-reset. The only Sun Fire high-end system HPUs that meet this assumption are the system controllers. Powering on a system controller causes the processor to begin executing SC-POST code from PROM.

For all other HPUs, some are tested by POST and some are tested (or monitored) by SMS software, and although it is generally the case that testing follows shortly after power on, it is not always so.

Furthermore, it is possible that POST can be run multiple times on a power-on HPU that is being dynamically reconfigured from one domain to another. It is also possible that POST and SMS can both detect faults on the same physical HPU. These differences in power and test control between the system controllers and other Sun Fire high-end system HPUs result in different policies proposed to manage them.

The system controller provides three sets of HPU LEDs:

- The state of the SC as a whole
- The state of the CP1500 slot
- The state of the SC spare slot

When the Sun Fire high-end system rack is powered on, power is supplied to the system controllers. The operating indicator LED, and the `OK to remove` indicator LEDs are, appropriately, initialized by the hardware. All three fault LEDs are illuminated so that the fault LEDs correctly reflect a fault, should there be a problem that prevents SC-POST from running.

SMS software, upon powering off the spare system controller, extinguishes the operating indicator LED, and illuminates the `OK to remove` indicator LEDs on the spare system controller. SMS software cannot adjust the operating indicator or `OK to remove` indicator LEDs after powering off the main SC, where the software is running.

SC-POST does the following:

- Upon completing testing, the SC with no faults found, extinguishes the SC fault indicator LED.
- Upon completing testing the HPCI slot with no faults found, SC-POST extinguishes the SC spare slot fault LED.
- Upon completing testing the control board with no faults found at the control board, the SC main, or the SC spare slot, SC-POST extinguishes the SC fault LED.

SC-OpenBoot PROM firmware and SMS software illuminate the proper fault LED(s) on the system controller after detecting a hardware error.

The following policies are used to manage LEDs on HPUs other than the system controllers.

- On every LED-equipped non-SC HPU within the Sun Fire high-end system rack, SMS assures that the operating indicator LED is steadily illuminated when power is applied to the HPU.
- On every LED-equipped non-SC HPU within the Sun Fire high-end system, SMS assures that the `OK to remove` indicator LED is steadily illuminated only when the HPU can be safely unplugged. Safety considerations apply both to the person unplugging the HPU and to preserving the correct and continuing operation of Sun Fire high-end system hardware and any running software.

Note – The Sun Fire high-end system correctly illuminates the operating indicator LED and correctly darkens the `OK to remove` indicator LEDs when HPUs are powered on or given a power-on-reset.

- The management of the fault LEDs and their user-visible behavior differs most between the SC and non-SC HPUs.

On the SC, the fault LEDs are illuminated at power on, maintained on during testing, and then extinguished if no fault is found.

Faults detected after SC-POST can cause later fault LED illumination.

So, except for the brief period when the SC is being tested by POST, the fault LEDs on the SC indicate that a fault has occurred since power on. The same holds true (an illuminated fault LED indicates that a fault has been detected since power on) for non-SC HPUs. Every LED-equipped non-SC HPU within the Sun Fire high-end system, SMS, upon power on or power on reset applied to that HPU, ensures that the fault indicator LED is extinguished.

- When directed to do so by POST, [“Power-On Self-Test \(POST\)” on page 147](#), or the hardware monitoring software, [“Environmental Events” on page 210](#), [“Hardware Error Events” on page 213](#), and [“SC Failure Events” on page 215](#), SMS steadily illuminates the fault indicator LED on an HPU. The fault indicator remains illuminated until the next power on or power-on-reset clears it, as described above in [“HPU LEDs” on page 156](#).

Domain Services

Sun Fire high-end system hardware incorporates internal, private point-to-point Ethernet connections between the SC and each domain. This network, called the Management Network (MAN), is used to provide support services for each domain. This chapter describes those services.

This chapter includes the following sections:

- [Management Network Overview](#)
- [Management Network Services](#)

Management Network Overview

The Management Network (MAN) function maintains the private point-to-point network connections between the SC and each domain. No packets addressed to one domain can be routed along the network connection between the SC and another domain ([FIGURE 8-1](#)).

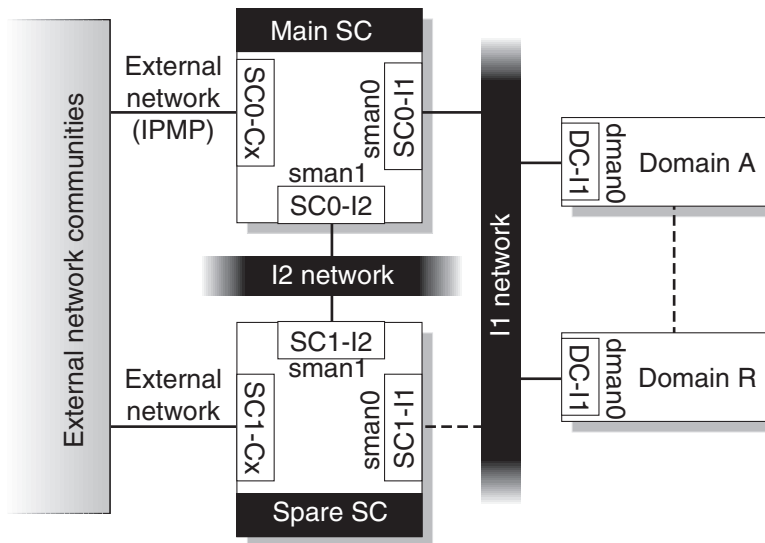

FIGURE 8-1 Management Network Overview

I1 Network

The hardware built into the Sun Fire high-end system chassis to support MAN is complex. It includes 18 network interfaces (NICs) on each SC that are connected in a point-to-point fashion to NICs located on each of the 18 expander I/O slots on the Sun Fire 15K system and on each of the nine expander I/O slots on the Sun Fire 12K system. Using this design, the number of point-to-point Ethernet links between an SC and a given DSD vary based on the number of I/O boards configured in that DSD. Each NIC from the SC connects to a hub and NIC on the I/O board. The NIC is an internal part of the I/O board and not a separate adapter card. Likewise, the Ethernet hub is on the I/O board. The hub is intelligent and can collect statistics. All of these point-to-point links are collectively called the I1 network. Since there can be multiple I/O boards in a given domain, multiple redundant network connections from the SC to a domain are possible.

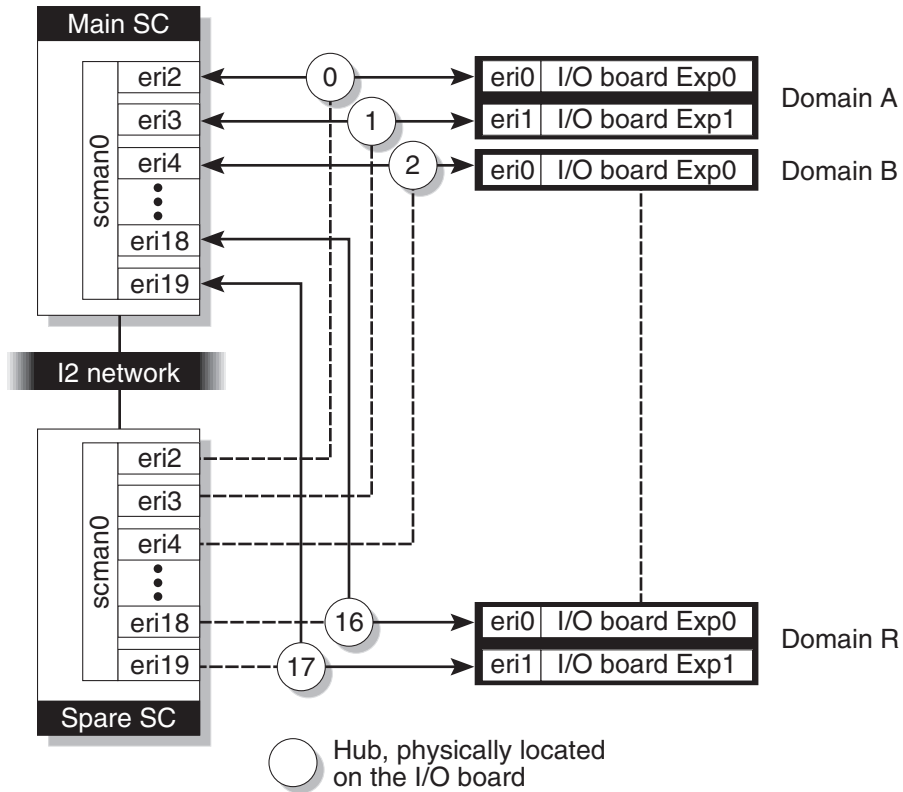

FIGURE 8-2 I1 Network Overview of the Sun Fire 15K

Note – The I1 MAN network is a *private* network, not a general purpose network. No external IP traffic should be routed across it. Access to MAN is restricted to the system controller and the domains.

On the SC, MAN software creates a meta-interface for the I1 network, presenting to the Solaris operating environment a single network interface, `scman0`. For more information refer to the Solaris `scman(1M)` man page.

MAN software detects communication errors and automatically initiates a path switch, provided an alternate path is available. MAN software also enforces domain isolation of network traffic on the I1 network. Similar software operates on the domain side.

I2 Network

There is also an internal network between the two system controllers consisting of two NICs per system controller. This network is called the I2 network. It is a private SC-to-SC network and is entirely separate from the I1 network.

MAN software creates a meta-interface for the I2 network as well. This interface is presented to the Solaris software as `scman1`. As with the I1 network, I2 has a mechanism for detecting path failure and switching paths, providing an alternative is available.

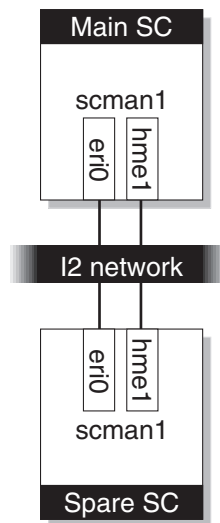

FIGURE 8-3 I2 Network Overview

The virtual network adapter on the SC presents itself as a standard network adapter. It can be managed and administered just like any other network adapter (for example, `qfe`, `hme`). The usual system administration tools such as `ndd(1M)`, `netstat(1M)`, and `ifconfig(1M)`, can be used to manage the virtual network adapter. Certain operations of these tools (for example, changing the Ethernet address) should not be allowed for security reasons.

MAN operates and is managed as an IP network with special characteristics (for example, IP forwarding is disallowed by the MAN software). As such, the MAN operation is the same as any other IP network, with the noted exception documented above. Domains can be connected to your network depending on your site configuration and security requirements. Connecting domains is not within the scope of this document; refer to the *System Administration Guide: Resource Management and Network Services*.

External Network Monitoring

External Network Monitoring for the Sun Fire high-end system provides highly available network connections from the SCs to customer networks called communities. This feature is built on top of the IP Network Multipathing (IPMP) framework provided in Solaris 9. For more information on IPMP refer to the *System Administration Guide: IP Services*.

External networks consist of up to two communities. You can have zero, one or two. Zero communities means external networks are not monitored. During installation, user communities are connected by physical cable to the RJ45 jacks on the SC connecting a node to the network.

For more information on connecting external networks, refer to the *Sun Fire 15K/12K System Site Planning Guide*.

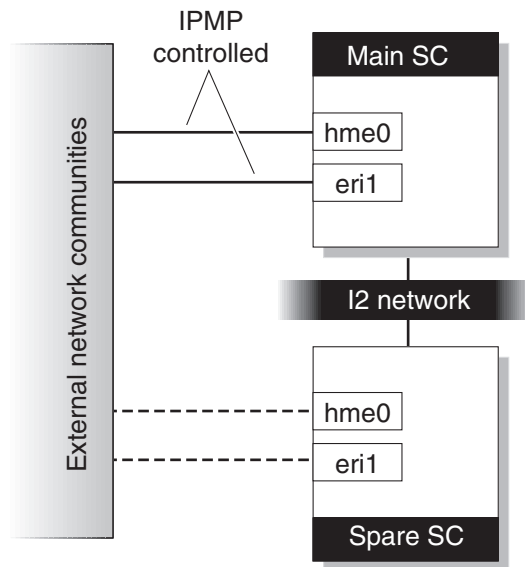

FIGURE 8-4 External Network Overview

The term *community* refers to an IP network at your site. For example, you may have an engineering community and an accounting community. A *community name* is used as the *interface group name*. An *interface group* is a group of network interfaces that attach to the same community.

Configuring External Network Monitoring requires allocating several additional IP addresses for each system controller.

The addresses can be categorized as follows:

- *Test Addressees* - These IP addresses are assigned to the external network interfaces on each system controller (`hme0` and `eri1`). Each IP test address is used to test the health of the particular network interface to which it is assigned. There is one IP test address assigned to each network interface. They are permanently associated with a particular network interface. If the network interface fails, the IP test address associated with the network interface becomes unreachable.

Note – *In the case of IPv6, test addresses are not used. The link local address is used.*

- *Failover Addresses* - There are two types of failover addresses:
 - *SC Path Group Specific Addresses* - These IP addresses are assigned to a particular interface group on each system controller. These IP addresses are used to provide highly available IP connectivity to a particular system controller for a given community. The SC path group specific address is reachable as long as one or more network interfaces in the interface group is functioning.

Note – An SC path group specific address is not needed if there is only one network interface in an interface group. Since there is no other network interface in the group to failover to, only the test addresses and the community failover addresses are required.

- *Community Failover Addresses*- These IP addresses are assigned to a particular community on the MAIN SC (that is, Community C1). They are used to provide IP connectivity to the MAIN SC, either SC 0 or SC1.

All external software should reference the community failover address when communicating with the SC. This address will always connect to the MAIN SC. That way, if a failover occurs, external clients do not need to alter their configuration to reach the SC. For more information on SC failover, see [“SC Failover” on page 179](#).

MAN Daemons and Drivers

For more information on the MAN daemon and device drivers, refer to the `mand(1M)`, and Solaris `scman(1M)` and `dman(1M)` man pages. See also [“Management Network Daemon” on page 48](#).

Management Network Services

The primary network services that MAN provides between the SC and the domains are:

- Domain consoles
- Message Logging
- Dynamic Reconfiguration (DR)
- Network boot/Solaris installation
- System Controller (SC) heartbeats

Domain Console

The software running in a domain (OpenBoot PROM, `kadb`, and Solaris software) uses the system console for critical communications.

The domain console supports a login session and is secure, since the default configuration of the Solaris environment allows only the console to accept superuser logins. Domain console access is provided securely to remote administrators over a possibly public network.

The behavior of the console reflects the health of the software running in the domain. Character echo for user entries are nearly equivalent to that of a 9600 baud serial terminal attached to the domain. Output characters that are not echoes of user input are typically either the output from an executed command, a command interpreter, or unsolicited log messages from the Solaris software. Activity on other domains or SMS support activity for the domain do not noticeably alter user entry echo response latency.

You can run `kadb` on the domain's Solaris software from the domain console. Interactions with OpenBoot PROM running on a domain use the domain console. The console can serve as the destination for log messages from the Solaris software; refer to `syslog.conf(4)`. The console is available when software (Solaris, OpenBoot PROM, `kadb`) is running on the domain.

You can open multiple connections to view the domain console output. However, the default is an exclusive *locked* connection.

For more information see [“SMS Console Window” on page 8](#).

A domain administrator can forcibly break the domain console connection held by another.

You can forcibly break into OpenBoot PROM or `kadb` from the domain console, however it is not recommended. (This is a replacement for the physical `L1-A` or `STOP-A` key sequence available on a Sun SPARC® system with a physical console.) SMS captures console output history for subsequent analysis of domain crashes. A snapshot of the last console output for every domain is available in `/var/opt/SUNWSMS/adm/domain_id/console`.

The Sun Fire high-end system provides the hardware to either implement a shared-memory console or implement an alternate network data path for console. The hardware utilized for a shared-memory console imposes less direct latency upon console data transfers, but is also used for other monitoring and control purposes for all domains, so there is a risk of latency introduced by contention for the hardware resources.

MAN provides private network paths to securely transfer domain console traffic to the SC, see [“Management Network Services” on page 165](#). The console has a dual-path nature so that at least one path provides acceptable console response latency when the Solaris software is running. The dual-path console is robust in the face of errors. It detects failures on one domain console path and fails over to the other domain console path automatically. It supports user-directed selection of the domain console path to use.

`smsconfig(1M)` is the SC configuration utility that initially configures or later modifies the hostname, IP address, and netmask settings used by management network daemon, `mand(1M)`. See [“Management Network Daemon” on page 48](#).

`mand` initializes and updates these respective fields in the platform configuration database (`pcd`).

`mand` is automatically started by `ssd`. The management network daemon runs on the main SC in *main* mode and on the spare SC in *spare* mode.

For more information, refer to the SMS `console(1M)`, `mand(1M)`, and `smsconfig(1M)` man pages and the Solaris `dman(1M)`, and `scman(1M)` man pages.

Message Logging

When configured to do so, MAN transports copies of important syslog messages from the domains to disk storage on the SC in order to facilitate failure analysis for crashed or unbootable domains. For more information, see [“Log File Maintenance” on page 200](#).

Dynamic Reconfiguration

Support for automatic network reconfiguration for a DR operation that removes the I/O board network connection endpoint from the domain, is initiated from the SC.

The MAN software layer is used to simplify the interface to the MAN hardware. MAN software handles the aspects of dynamic reconfiguration (DR) used by a DSD without requiring network configuration work by the domain or platform administrator.

Software in the domains using MAN need not be aware of which SC is currently the main SC. For more information on dynamic reconfiguration, refer to the *System Management Services (SMS) 1.4 Dynamic Reconfiguration User Guide*.

Network Boot and Solaris Software Installation

The SC provides network Solaris boot services to each domain.

Note – This is not intended to imply that diskless Sun Fire high-end system domains can be supported entirely by network services from the SC; the SC network boot service is intended primarily for recovery after a catastrophic disk failure on the domain.

When Solaris software is first installed on a domain, the network interface connecting it to the MAN is automatically created for subsequent system reboots. There are no additional tasks required by the domain administrator to configure or use MAN.

MAN is configured as a private network. A default address assignment for the management network is provided using the IP address space reserved for private networks. You can override the default address assignment for MAN to handle the case where the Sun Fire high-end system is connected to a private customer network that already uses the selected MAN default IP address range.

The SC supports simultaneous network boots of domains running at least two different versions of Solaris software.

The SC provides software installation services to, no more than one domain at a time.

SC Heartbeats

The I2 network is the intersystem controller communication. This is also called the heartbeat network. SMS failover mechanisms on the main use this network as one means of determining the health of the spare SC. For more information see, [“SC Failover” on page 179](#). For a description of the I2 network, see [“I2 Network” on page 162](#).

Domain Status

Status functions return measured values that characterize the state of the server hardware or software. As such, these functions are used both to provide values for status displays and input to monitoring software that periodically polls status functions and verifies that the values returned are within normal operational limits. Monitoring and event detection functions that use the status functions are described in this chapter.

This chapter includes the following sections:

- [Software Status](#)
- [Hardware Status](#)
- [SC Hardware and Software Status](#)

Software Status

The software state consists of status information provided by the software running in a domain. The identity of the software component currently running (for example, POST, OpenBoot PROM, or Solaris software) is available. Additional status information is available (booting, running, panicking).

SMS software provides the following command(s) to display the status of the software, if any, currently running in a domain.

- `showboards`
- `showdevices`
- `showenvironment`
- `showobpparams`
- `showplatform`
- `showxirstate`

Status Commands

showboards Command

`showboards(1M)` displays the assignment information and status of the DCUs. These include the following: Location, Power, Type of board, Board status, Test status, and Domain.

If no options are specified, `showboards` displays all DCUs including those that are assigned or available for the platform administrator. For the domain administrator or configurator, `showboards` displays only those DCUs for those domains for which the user has privileges, including those boards that are assigned or available and in the domain's available component list.

If `domain_indicator` is specified, this command displays which DCUs are assigned or available to the given domain. If the `-a` option is used, `showboards` displays all boards including DCUs.

For examples and more information, see [“To Obtain Board Status” on page 73](#) and refer to the `showboards` manpage.

showdevices Command

`showdevices(1M)` displays configured physical devices on system boards and the resources made available by these devices. Usage information is provided by applications and subsystems that are actively managing system resources. The predicted impact of a system board DR operation may be optionally displayed by performing an offline query of managed resources.

`showdevices` gathers device information from one or more Sun Fire high-end system domains. The command uses the `dca(1M)` as a proxy to gather the information from the domains.

For examples and more information, see [“To Obtain Device Status” on page 90](#) and refer to the `showdevices` manpage.

showenvironment Command

`showenvironment(1M)` displays environmental data including: Location, Device, Sensor, Value, Unit, Age, Status. For fan trays, Power, Speed, and Fan Number are displayed. For bulk power, the Power, Value, Unit, and Status are shown.

If a domain *domain_indicator* is specified, environmental data relating to the domain is displayed, providing that the user has domain privileges for that domain. If a domain is not specified, all domain data permissible to the user will be displayed.

DCUs (for example, CPU, I/O) belong to a domain and you must have domain privileges to view their status. Environmental data relating to such things as fan trays, bulk power, or other boards are displayed without domain permissions. You can also specify individual reports for temperatures, voltages, currents, faults, bulk power status, and fan tray status with the `-p` option. If the `-p` option is not present, all reports will be shown.

For examples and more information, see [“Environmental Status” on page 175](#) and refer to the `showenvironment` man page.

showobpparams Command

`showobpparams(1M)` displays OpenBoot PROM bringup parameters. `showobpparams` allows a domain administrator to display the virtual NVRAM and REBOOT parameters passed to OpenBoot PROM by `setkeyswitch(1M)`.

For examples and more information, see [“Setting the OpenBoot PROM Variables” on page 95](#) and refer to the `showobpparams` man page.

showplatform Command

`showplatform(1M)` displays the available component list and domain state of each domain.

A domain is identified by a *domain_tag* if one exists. Otherwise it is identified by the *domain_id*, a letter in the set A–R. The letter set is case insensitive. The Solaris *hostname* is displayed if one exists. If a *hostname* has not been assigned to a domain, Unknown is printed.

The following is a list of domain statuses:

Status	Description
Unknown	The domain state could not be determined or for Ethernet addresses, it indicates the domain idprom image file does not exist. You need to contact your Sun service representative.
Powered Off	The domain is powered off.
Keyswitch Standby	The keyswitch for the domain is in STANDBY position.
Running Domain POST	The domain power-on self-test is running.

Loading OBP	The OpenBoot PROM for the domain is being loaded.
Booting OBP	The OpenBoot PROM for the domain is booting
Running OBP	The OpenBoot PROM for the domain is running.
In OBP Callback	The domain has been halted and has returned to the OpenBoot PROM.
Loading Solaris	The OpenBoot PROM is loading the Solaris software
Booting Solaris	The domain is booting the Solaris software
Domain Exited OBP	The domain OpenBoot PROM exited.
OBP Failed	The domain OpenBoot PROM failed.
OBP in sync Callback to OS	The OpenBoot PROM is in sync callback to the Solaris software.
Exited OBP	The OpenBoot PROM has exited.
In OBP Error Reset	The domain is in OpenBoot PROM due to an error reset condition.
Solaris Halted in OBP	Solaris software is halted and the domain is in OpenBoot PROM.
OBP Debugging	The OpenBoot PROM is being used as a debugger
Environmental Domain Halt	The domain was shut down due to an environmental emergency.
Booting Solaris Failed	OpenBoot PROM running, boot attempt failed.
Loading Solaris Failed	OpenBoot PROM running, loading attempt failed.
Running Solaris	Solaris software is running on the domain.
Solaris Quiesce In-Progress	A Solaris software quiesce is in progress.
Solaris Quiesced	Solaris software has quiesced.
Solaris Resume In-Progress	A Solaris software resume is in progress
Solaris Panic	Solaris software has panicked, panic flow has started.
Solaris Panic Debug	Solaris software panicked, and is entering debugger mode.
Solaris Panic Continue	Exited debugger mode and continuing panic flow.
Solaris Panic Dump	Panic dump has started.
Solaris Halt	Solaris software is halted.
Solaris Panic Exit	Solaris software exited as a result of a panic.
Environmental Emergency	An environmental emergency has been detected
Debugging Solaris	Debugging Solaris software; this is not a hung condition.

Solaris Exited	Solaris software has exited.
Domain Down	The domain is down and the setkeyswitch in the ON, DIAG, or SECURE position.
In Recovery	The domain is in the midst of an automatic system recovery.

Domain status reflects two cases. The first is that `dsmd` is busy trying to recover the domain and the second is that `dsmd` has given up trying to recover the domain. In the second case you always see “Domain Down.” In the first case you see either “Domain Down” or some other status. To recover from a “Domain Down” in *either* case, use `setkeyswitch off`, `setkeyswitch on`.

```
sc0:sms-user:> setkeyswitch off
sc0:sms-user:> setkeyswitch on
```

For examples and more information, see [“To Obtain Domain Status” on page 74](#) and refer to the `showplatform` man page.

showxirstate Command

`showxirstate(1M)` displays CPU dump information after a reset pulse is sent to the processors. This save state dump can be used to analyze the cause of abnormal domain behavior. `showxirstate` creates a list of all active processors in that domain and retrieves the save state information for each processor, including its processor signature.

`showxirstate` data resides, by default, in `/var/opt/SUNWSMS/adm/domain_id/dump`.

For examples and more information, refer to the `showxirstate` man page.

Solaris Software Heartbeat

During normal operation, the Solaris environment produces a periodic heartbeat indicator readable from the SC. `dsmd` detects the absence of heartbeat updates for a running Solaris system as a hung Solaris. Hangs are not detected for any software components other than the Solaris software.

Note – The Solaris software heartbeat should not be confused with the SC-to-SC (hardware) heartbeat or the heartbeat network, both used to determine the health of failover. For more information see, [“SC Heartbeats” on page 168](#).

The only reflection of the Solaris heartbeat occurs when `dsmd` detects a failure to update the Solaris heartbeat of sufficient duration to indicate that the Solaris software is hung. Upon detection of a Solaris software hang, `dsmd` conducts an ASR.

Hardware Status

The hardware status functions report information about the hardware configuration, hardware failures detected, and platform environmental state.

Hardware Configuration

The following hardware configuration status is available from the Sun Fire high-end system management software:

- Hardware components physically present on each board (as detected by POST)
- Hardware components not in use because they failed POST
- Presence or absence of all hot-pluggable units (HPUs) (for example, system boards)
- Hardware components not in use because they were on the blacklist when POST was invoked (see [“Power-On Self-Test \(POST\)” on page 147](#))
- Contents of the SEEPROM for each FRU including the part number and serial number

Note – The hardware configuration status available to SMS running on the SC is limited to presence /absence. It includes no information about the I/O configuration; such as, where I/O adaptors are plugged in and what devices are attached to those I/O adaptors. Such information is available only to the software running on the domain that owns the I/O adaptor.

The hardware configuration supported by functions described in this section excludes I/O adaptors and I/O devices. `showboards` displays all hardware components that are present.

As described in [“Blacklist Editing” on page 148](#), the current contents of the component blacklist(s) can always be viewed and altered.

Environmental Status

The following hardware environmental measurements are available:

- Temperatures
- Power voltage and amperage
- Fan status (stopped, low-speed, high-speed, failed)
- Power status
- Faults

`showenvironment` displays every environmental measurement that can be taken within the Sun Fire high-end system rack.

▼ To Display the Environment Status for Domain A

1. Log in to the SC.

Platform administrators can view any environment status on the entire platform. Domain administrators can see the environment status only for those domains for which they have privileges.

2. Type:

```
sc0:sms-user:> showenvironment -d A
```

As described in [“HPU LEDs” on page 156](#), the operating indicator LEDs on Sun Fire high-end system HPUs visibly reflect that the HPUs are powered on and the OK to remove indicator LEDs visibly reflect those that can be unplugged.

Hardware Error Status

`dsmd` monitors the Sun Fire high-end system hardware operational status and reports errors. The occurrence of some errors are directly reported to the SC (for example, the error register(s) in every ASIC propagate to the SBBC on the SC that provides an error summary register). Although the occurrence of some errors is indicated by an interrupt delivered to the SC, some error states may require the SC to monitor hardware registers for error indications. When a hardware error is detected, `esmd` follows the established procedures for collecting and clearing the hardware error state.

The following types of errors can occur on Sun Fire high-end system hardware:

- Domain stops, fatal hardware errors that terminate all hardware operations in a domain
- Record stops that cause the hardware to stop collecting transaction history when a data transfer error (for example, CE ECC) occurs

- SPARC processor error conditions such as RED_state/watchdog reset
- Nonfatal ASIC-detected hardware failures

Hardware error status is generally not reported as a status. Rather, event handling functions perform various actions when hardware errors occur such as logging errors, initiating ASR, and so forth. These functions are discussed in [“Domain Events” on page 199](#).

Note – As described in [“HPU LEDs” on page 156](#), the fault LEDs, after POST completion, identify Sun Fire high-end system HPUs in which faults have been discovered since last powered on or submitted to a power on reset.

SC Hardware and Software Status

Proper operation of SMS depends upon proper operation of the hardware and the Solaris software on the SC. The ability to support automatic failover from the main to the spare system controller requires properly functioning hardware and software on the spare. SMS software running on the main system controller must either be functioning sufficiently to diagnose a software or hardware failure in a manner that can be detected by the spare or it must fail in a manner that can be detected by the spare.

SC-POST determines the status of system controller hardware. It tests and configures the system controller at power-on or power-on reset.

The SC does not boot if the SC fails to function.

If the control board fails to function, the SC boots normally, but without access to the control board devices. The level of hardware functionality required to boot the system controller is essentially the same as that required for a standalone SC.

SC-POST writes diagnostic output to the SC console serial port (TTY-A). Additionally, SC-POST leaves a brief diagnostics status summary message in an NVRAM buffer that can be read by a Solaris driver and logged and/or displayed when the Solaris software boots.

SC firmware and software display information to identify and service SC hardware failures.

SC firmware and software provide a software interface that verifies that the system controller hardware is functional. This selects a working system controller as main in a high-availability SC configuration.

The system controller LEDs provide visible status regarding power and detected hardware faults as described in [“HPU LEDs” on page 156](#).

Solaris software provides a level of self-diagnosis and automatic recovery (panic and reboot). Solaris software utilizes the SC hardware watchdog logic to trap hang conditions and force an automatic recovery reboot.

There are four hardware paths of communication between the SCs (two Ethernet connections, the heartbeat network, and one SC-to-SC heartbeat signal) that are used in the high-availability SC configuration by each SC to detect hangs or failures on the other SC.

SMS practices self-diagnosis and institutes automatic failure recovery procedures, even in non-high-availability SC configurations.

Upon recovery, SMS software either takes corrective actions as necessary to restore the platform hardware to a known, functional configuration or reports the inability to do so.

SMS software records and logs sufficient information to allow engineering diagnosis of single-occurrence software failures in the field.

SMS software takes a noticeable interval to initialize itself and become fully functional. The user interfaces behave predictably during this interval. Any rejections of user commands are clearly identified as due to system initialization with advice to try again after a suitable interval.

SMS software implementation uses a distributed client/server architecture. Any errors encountered during SMS initialization, due to attempts to interact with a process that has not yet completed initialization, are dealt with silently.

SC Failover

SC failover maximizes Sun Fire high-end system uptime by adding high availability features to its administrative operations. A Sun Fire high-end system contains two SCs. Failover provides software support to a high-availability two SC system configuration.

The main SC provides all resources for the entire Sun Fire high-end system. If hardware or software failures occur on the main SC or on any hardware control path (for example, console bus interface or Ethernet interface) from the main SC to other system devices, then SC failover software automatically triggers a failover to the spare SC. The spare SC then assumes the role of the main and takes over all the main SC responsibilities. In a high-availability two SCs system configuration, SMS data, configuration, and log files are replicated on the spare SC. Active domains are not affected by this switch.

This chapter includes the following sections:

- [Overview](#)
- [Fault Monitoring](#)
- [File Propagation](#)
- [Failover Management](#)
- [Failover CLIs](#)
- [Command Synchronization](#)
- [Data Synchronization](#)
- [Failure and Recovery](#)
- [Security](#)

Overview

In the current high-availability SC configuration, one SC acts as a “hot spare” for the other.

Failover eliminates the single point of failure in the management of the Sun Fire high-end system. `fomd` identifies and handles as many multiple points failure as possible. Some failover scenarios are discussed in [“Failure and Recovery” on page 191](#).

At anytime during SC failover, the failover process does not adversely affect any configured or running domains except for temporary loss of services from the SC.

In a high-availability SC system:

- If a fault (software or hardware) is detected on the main SC, `fomd` automatically fails over to the spare SC.
- If the spare SC detects that the main SC has stopped communicating with it, it initiates a takeover and assumes the role of main.

The failover management daemon (`fomd(1M)`) is the core of the SC failover mechanism. It is installed on both the main and spare SC.

The `fomd` daemon performs the following functions:

- Determines an SC’s role; main or spare.
- Requests the general health status of the remote SC hardware and software in the form of a periodic health status message request sent over the SMS management network (MAN) that exists between the two SCs.
- Checks and/or handles recoverable and unrecoverable hardware and software faults.
- Makes every attempt to eliminate the possibility of split-brain condition between the two SCs. (A condition is considered *split-brain* when both the SCs think they are the main SC.)
- Provides a recovery time from a main SC failure of between five and eight minutes. The recovery time includes the time for `fomd` to detect the failure, reach an agreement on the failure, and assume the main SC responsibilities on the spare SC.
- Logs an occurrence of an SC failover in the platform message log.

Services that would be interrupted during a SC failover include:

- All network connections
- Any SC-to-domain and domain-to-SC IOSRAM/Mailbox communication
- Any process running on the main SC

You do not need to know the hostname of the main SC in order to establish connections to it. As part of configuring SMS (refer to the `smsconfig(1M)` man page), a logical hostname was created which will always be active on the main SC. Refer to the *Sun Fire 15K/12K System Site Planning Guide* and the *System Management Services (SMS) 1.4 Installation Guide* for information on the creation of the logical hostnames in your network database.

Operations interrupted by an SC failover can be recovered after the failover completes. Reissuance of the interrupted operation causes the operation to resume and continue to completion.

All automated functions provided by `fomd` resume without operator intervention after SC failover. Any recovery actions interrupted before completion by the SC failover will restart.

Fault Monitoring

There are three types of failovers:

1. Main initiated

A main initiated failover is where the `fomd` running on the main SC yields control to the spare SC in response to either an unrecoverable local hardware/software failure or an operator request.

2. Spare initiated (takeover)

In a spare initiated failover (takeover), the `fomd` running on the spare determines that the main SC is no longer functioning properly.

3. Indirect triggered takeover

If the I2 network path between the SCs is down and there is a fault on the main, then the main switches itself to the role of spare and upon detecting this, the spare SC assumes the role of main.

In the last two scenarios, the spare `fomd` eliminates the possibility of a split-brain condition by resetting the main SC.

When a failover occurs, either software controlled or user forced, `fomd` deactivates the failover mechanism. This eliminates the possibility of repeatedly failing over back and forth between the two SCs.

File Propagation

One of the purposes of the `fomd` is propagation of data from the main SC to the spare SC through the interconnects that exist between the two SCs. This data includes configuration, data, and log files.

The `fomd` daemon performs the following functions:

- Propagates all native SMS files from the main to the spare SC at startup. These include all the domain data directories, the `pcd` configuration files, the `/etc/opt/SUNWSMS/config` directory, the `/var/opt/SUNWSMS/adm` platform and domain files, and the `.logger` files. Any user-created application files are not propagated unless specified in the `cmdsycn` scripts.
- Only propagates files modified since the last propagation cycle.
- In the event of a failover, propagates all modified SMS files before the spare SC assumes its role as main.
- The I2 network must be operative for the transfer of data to occur.

Note – Any changes made to the network configuration on one SC using `smsconfig -m` must be made to the other SC as well. Network configuration is not automatically propagated.

Should both interconnections between the two SCs fail, failover can still occur provided main and spare SC accesses to the high-availability srams (HASram) remain intact. Due to the failure of both interconnections, propagation of SMS data can no longer occur, creating the potential of stale data on the spare SC. In the event of a failover, `fomd` on the new main keeps the current state of the data, logs the state and provides other SMS daemons/clients information of the current state of the data.

When either of the interconnects between the two SCs is healthy again, data is pulled over depending on the timestamp of each SMS files. If the timestamp of the file is earlier than the one on the now spare SC, it gets transferred over. If the timestamp of the file is later than the one on the spare SC, no action is taken.

Failover cannot occur when both of the following conditions are met:

- Both interconnects between the two SCs fail
- Access to both HASrams fail

This is considered a quadruple fault, and failover will be disabled until at least one of the links is restored.

Failover Management

Startup

For the failover software to function, both SCs must be present in the system. The determination of main and spare roles are based in part on the SC number. This slot number does not prevent a given SC from assuming either role, it is only meant to control how it goes about doing so.

If SMS is started on one SC first, it will become main. If SMS starts up on both SCs at essentially the same time, whichever SC first determines that the other SC either is not main or is not running SMS will become main.

There is one case during start-up where, if SC0 is in the middle of the start-up process, and it queries SC1 for its role and the SC1 role cannot be confirmed, SC0 tries to become main. SC0 will reset SC1 during this process. This is done to prevent both SCs from assuming the main role; a condition known as split brain. The reset occurs even if the failover mechanism is deactivated.

Main SC

Upon startup, the `fomd` running on the main SC begins periodically testing the hardware and network interfaces. Initially the failover mechanism is disabled (internally) until at least one status response has been received from the remote (spare) SC indicating that it is healthy.

If a local fault is detected by the main `fomd` during initial startup, failover occurs when all of the following conditions are met:

1. The I2 network was not the source of the fault.
2. The remote SC is healthy (as indicated by the health status response).
3. The failover mechanism has not been deactivated.

Spare SC

Upon startup, `fomd` runs on the spare SC and begins periodically testing the software, hardware, and network interfaces.

If a local fault is detected by the `fomd` running on the spare SC during initial startup, it informs the main `fomd` of its debilitated state.

Failover CLIs

`setfailover` Command

`setfailover` modifies the state of the SC failover mechanism. The default state is `on`. You can set failover to:

State	Definition
<code>on</code>	Enables failover for systems that previously had failover disabled due to a failover or an operator request. This option instructs the command to attempt to re-enable failover only. If failover cannot be re-enabled, subsequent use of the <code>showfailover</code> command indicates the current failure that prevented the enable.
<code>off</code>	Disables the failover mechanism. This prevents a failover until the mechanism is re-enabled.
<code>force</code>	Forces a failover to the spare SC. The spare SC must be available and healthy.

Note – In the event a patch must be applied to SMS 1.4, failover must be disabled before the patch is installed. Refer to the *System Management Services (SMS) 1.4 Installation Guide*.

For more information and examples refer to the `setfailover` man page.

showfailover Command

showfailover allows you to monitor the state and display the current status of the SC failover mechanism. The -v option displays the current status of all monitored components.

```
xc30p13-sc0:sms-svc:13> showfailover -v
SC Failover Status:      ACTIVE
Status of Shared Memory:
    HASRAM (CSB at CS0): .....Good
    HASRAM (CSB at CS1): .....Good

Status of xc30p13-sc0:
    Role: .....MAIN
    SMS Daemons: .....Good
    System Clock: .....Good
    Private I2 Network: .....Good
    Private HASRAM Network:.....Good
    Public Network.....NOT TESTED
    System Memory: .....38.9%
    Disk Status:
        /: .....17.4%
Console Bus Status:
    EXB at EX1: .....Good
    EXB at EX2: .....Good
    EXB at EX4: .....Good

Status of xc30p13-sc1:
    Role: .....SPARE
    SMS Daemons: .....Good
    System Clock: .....Good
    Private I2 Network: .....Good
    Private HASRAM Network:.....Good
    Public Network: .....NOT TESTED
    System Memory: .....34.2%
    Disk Status:
        /: .....17.1%
Console Bus Status:
    EXB at EX1: .....Good
    EXB at EX2: .....Good
    EXB at EX4: .....Good
```

The `-r` option displays the SC role: main, spare or unknown. For example:

```
sc0:sms-user:> showfailover -r
MAIN
```

If you do not specify an option, then only the state information is displayed:

```
sc0:sms-user:> showfailover
SC Failover Status: state
```

The failover mechanism can be in one of four states: ACTIVATING, ACTIVE, DISABLED, and FAILED.

TABLE 10-1 Failover Mechanisms

State	Definition
ACTIVATING	The failover mechanism is preparing to transition to the ACTIVE state. Failover becomes active when all tests have passed and files have been synchronized.
ACTIVE	The failover mechanism is enabled and functioning normally.
DISABLED	The failover mechanism has been disabled due to the occurrence of a failover or an operator request (<code>setfailover off</code>)
FAILED	Identifies that the failover mechanism has detected a failure that prevents a failover from being possible or failover has not yet completed activation.

In addition `showfailover` displays the state of each of the network interface links monitored by the failover processes. The display format is as follows:

```
network iff device name: [GOOD|FAILED]
```

`showfailover` returns a failure string describing the failure condition. Each failure string has a code associated with it. The following table defines the codes and associated failure strings.

String	Explanation
None	No failure.
S-SC EXT NET	The spare SC external network interface has failed.
S-SC CONSOLE BUS	A fault has been detected on the spare SC console bus path(s).
S-SC LOC CLK	The spare SC local clock has failed.
S-SC DISK FULL	The spare SC system is full.
S-SC IS DOWN	The spare SC is down and/or unresponsive. If this message results from the I2 network/HASRAMs being down then the spare SC could still be running. Login to the spare SC to verify.
S-SC MEM EXHAUSTED	The spare SC memory/swap space has been exhausted.
S-SC SMS DAEMON	At least one SMS daemon could not be started/restarted on the spare SC.
S-SC INCOMPATIBLE SMS VERSION	The spare SC is running a different version of SMS software. Both SCs must be running the same version.
I2 NETWORK/HASRAM DOWN	Both interfaces for communication between the SCs are down. The main cannot tell what version of SMS is running on the spare nor what its state is. It declares the spare down and logs a message to that effect. Dependent services including file propagation are unavailable.

For examples and more information, refer to the `showfailover` man page.

Command Synchronization

If an SC failover occurs during the execution of a command, you can restart the same command on the new main SC.

All commands and actions do the following:

- Mark the start of a command or action.
- Remove or indicate the completion of a command or action.
- Keep any state transition and/or pertinent data which SMS can use to resume the command.

fomd provides:

- Command sync support for `dsmd(1M)` to automatically resume ASR reboots of any or all affected domain(s) after a failover.
- Command sync support for all SMS DR related daemons and CLIs to restart the last DR operation after a failover.

The four CLIs in SMS that require command sync support are `addboard`, `deleteboard`, `moveboard`, and `rcfgadm`.

cmdsycn CLIs

The *cmdsycn* commands provide the ability to initialize a script or command with a `cmdsycn` descriptor, update an existing `cmdsycn` descriptor execution point, or cancel a `cmdsycn` descriptor from the spare SC's list of recovery actions. Commands or scripts can also be run in a `cmdsycn` envelope.

In the case of an SC failover to the spare, initialization of a `cmdsycn` descriptor on the spare SC allows the spare SC to restart or resume the target script or command from the last execution point set. These commands only execute on the main SC, and have no effect on the current `cmdsycn` list if executed on the spare.

Commands or scripts invoked with the `cmdsycn` commands when there is no enabled spare SC results in a no-op operation. That is, command execution proceeds as normal, but a log entry in the platform log indicates that a `cmdsycn` attempt has failed.

initcmdsycn Command

`initcmdsycn(1M)` creates a `cmdsycn` descriptor. The target script or command and its associated parameters are saved as part of the `cmdsycn` data. The exit code of the `initcmdsycn` command provides a `cmdsycn` descriptor that can be used in subsequent `cmdsycn` commands to reference the action. Actual execution of the target command or script is not performed. For more information, refer to the `initcmdsycn(1M)` man page.

savecmdsycn Command

`savecmdsycn(1M)` saves a new execution point in a previously defined `cmdsycn` descriptor. This allows a target command or script to restart execution at a location associated with an identifier. The target command or script supports the ability to be restarted at this execution point, otherwise the restart execution is at the beginning of the target command or script. For more information, refer to the `savecmdsycn(1M)` man page.

cancelcmdsync Command

`cancelcmdsync(1M)` removes a `cmdsync` descriptor from the spare restart list. Once this command is run, the target command or script associated with the `cmdsync` descriptor is not restarted on the spare SC in the event of a failover. Take care to ensure that all target commands or scripts contain a `initcmdsync` command sequence as well as a `cancelcmdsync` sequence after the normal or abnormal termination flows. For more information, refer to the `cancelcmdsync (1M)` man page.

runcmdsync Command

`runcmdsync(1M)` executes the specified target command or script under a `cmdsync` wrapper. You cannot restart at execution points other than the beginning. The target command or script is executed through the system command after creation of the `cmdsync` descriptor. Upon termination of the system command, the `cmdsync` descriptor is removed from the `cmdsync` list, and the exit code of the system command returned to the user. For more information, refer to the `runcmdsync (1M)` man page.

showcmdsync Command

`showcmdsync(1M)` displays the current `cmdsync` descriptor list. For more information, refer to the `showcmdsync (1M)` man page.

Data Synchronization

Customized data synchronization is provided in SMS by the `setdatasync(1M)` command. `setdatasync` enables you to specify a user-created file to be added to or removed from the data propagation list.

setdatasync Command

The `setdatasync` list identifies the files to be copied from the main to the spare system controller (SC) as part of data synchronization for automatic failover. The specified user file and the directory in which it resides must have read and write permissions for you on both SCs. You must also have platform or domain privileges.

The data synchronization process checks the user-created files on the main SC for any changes. If the user-created files on the main SC have changed since the last propagation, they are repropagated to the spare SC. By default, the data synchronization process checks a specified file every 60 minutes; however, you can use `setdatasync` to indicate how often a user file is to be checked for modifications.

You can also use `setdatasync` to propagate a specified file to the spare SC without adding the file to the data propagation list.

Using `setdatasync backup` can slow down automatic `fomd` file propagation.

The time required to execute `setdatasync backup` is proportional to the number of files being transferred. Other factors that can affect the speed of file transfer include: the average size of files being transferred, the amount of memory available on the SCs, the load (CPU cycles and disk traffic) on the SCs, and whether the I2 network is functioning.

The following statistics assume an average file size of 200KB:

On a lightly loaded system with a functioning I2 network, FOMD can transfer about 750 files per minute.

On a lightly loaded system with no functioning I2 network, FOMD can transfer about 250 files per minute.

Note – There are repropagation constraints you should be aware of *before* using this command. For more information and examples, refer to the `setdatasync (1M)` man page.

showdatasync Command

`showdatasync` provides the current status of files being propagated (copied) from the main SC to its spare. `showdatasync` also provides the list of files registered using `setdatasync` and their status. Data propagation synchronizes data on the spare SC with data on the main SC, so that the spare SC is current with the main SC if an SC failover occurs.

For more information, refer to the `showdatasync (1M)` man page.

Failure and Recovery

In a high-availability configuration, `fomd` manages the failover mechanism on the local and remote SCs. `fomd` detects the presence of local hardware and software faults and determines the appropriate action to take.

`fomd` is responsible for detecting faults in the following categories:

-
- | | |
|---|---|
| a | All relevant hardware buses that are local to the SC Control board (CB)/CPU board. |
| b | The external network interfaces. |
| c | The I2 network interface between the SCs. |
| d | Unrecoverable software failures. This category is for those cases where an SMS software component (daemon) crashes and cannot be restarted after three attempts; the file system is full; the heap is exhausted and so forth. |
-

FIGURE 10-1 illustrates the failover fault categories.

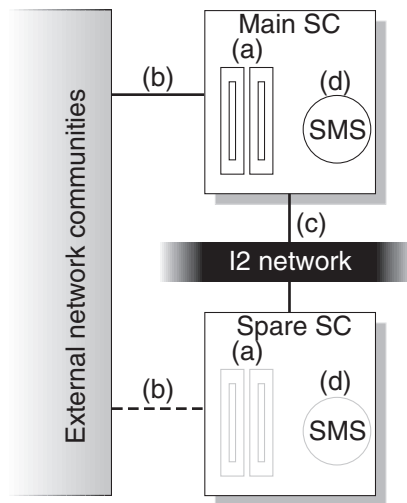

FIGURE 10-1 Failover Fault Categories

The following table illustrates how faults in the categories affect the failover mechanism. Assume that the failover mechanism is activated.

Failure Point	Main SC	Spare SC	Failover	Notes
a	X		X	Failover to spare occurs.
a		X	Disables	No effect on the main SC, but the spare SC has suffered a hardware fault so failover is disabled.
b	X			Failover to spare.
b		X	No effect	The fact that the spare SC external network interfaces have failed does not affect the failover mechanism.
c			No effect	Main and spare SC log the fault.
d	X		X	Failover to the spare SC assuming that it is healthy.
d		X	Disables	Failover is disabled because the spare SC is deemed unhealthy at this point.

Failover on Main SC (Main Controlled Failover)

The following lists events for the main `fomd` during SC failover in order.

1. Detects the fault.
2. Stops generating heartbeats.
3. Tells the remote failover software to start a takeover timer. The purpose of this timer is to provide an alternate means for the remote (spare) SC to takeover if for any reason the main hangs up and never reaches Number 10.
4. Starts the SMS software in spare mode.
5. Removes the logical IP interface.
6. Enables the console bus caging mechanism.
7. Triggers propagation of any modified SMS files to the spare SC/HASrams.
8. Stops file propagation monitoring.
9. Shuts down main-specific daemons and sets its role to UNKNOWN.
10. Logs a failover event.
11. Notifies remote (spare) failover software that it should assume the role of main. If the takeover timer expires before the spare is notified, the remote SC will takeover on its own.

The following lists the order of events for the spare `fomd` during failover.

1. Receives message from the main `fomd` to assume main role, or the takeover timer expires. If the former is true, then the takeover timer is stopped.
2. Resets the old main SC.
3. Notifies `hwad`, `frad`, and `mand` to configure itself in the main role.
4. Assumes the role of main.
5. Starts generating heartbeat interrupts.
6. Configures the logical IP interface.
7. Disables the console bus caging mechanism.
8. Starts the SMS software in main mode.
9. Prepare the `darbs` to receive interrupts.
10. Logs a role reversal event, spare to main.
11. The spare SC is now the main and `fomd` deactivates the failover mechanism.

Fault on Main SC (Spare Takes Over Main Role)

In this scenario the spare SC takes main control in reaction to the main SC going away. The most important aspect of this type of failover is the prevention of the split-brain condition. Another assumption is that the failover mechanism is not deactivated. If this is not the case, then no takeover can occur.

The spare `fomd` does the following:

- Notices the main SC is not healthy.

From the spare `fomd` perspective, this phenomenon can be caused by two conditions; the main SC is truly dead, and/or the I2 network interface is down.

In the former case, a failover is needed (provided that the failover mechanism is activated) while in the latter it is not. To identify which is the case, the spare `fomd` polls for the presence of heartbeat interrupts from the main SC to determine if the main SC is still up and running. As long as there are heartbeat interrupts being received, and/or the failover mechanism is deactivated and/or disabled, no failover occurs.

In the case where no interrupts are detected, but the failover mechanism is deactivated, the spare `fomd` does not attempt to take over unless the operator manually activates the failover mechanism using the CLI command, `setfailover`. Otherwise, if the spare SC is healthy, the spare `fomd` proceeds to take over the role of main as listed.

- Initiates a takeover by resetting the remote (main) SC.

The following lists the events for the spare `fomd`, in order, during failover:

1. Reconfigures itself as main. This includes taking over control of the I²C bus, configuring the logical main SC IP address, and starting up the necessary SMS software daemons.
2. Starts generating heartbeat interrupts.
3. Configures the logical IP interface.
4. Disables console bus caging.
5. Starts the SMS software in main mode.
6. Configures the DARB interrupts.
7. Logs a takeover event.
8. The spare `fomd`, now the main, deactivates the failover mechanism.

I2 Network Fault

The following lists the events, in order, that occur after an I2 network fault.

1. The main `fomd` detects the I2 network is not healthy.
2. The main `fomd` stops propagating files and checkpointing data over to the spare SC.
3. The spare `fomd` detects the I2 network is not healthy.

From the spare `fomd` perspective, this phenomenon can be caused by two conditions; the main SC is truly dead, and/or the I2 network interface is down. In the former case, the corrective action is to fail over, while in the latter it is not. To identify which is the case, the `fomd` starts polling for the presence of heartbeat interrupts from the main SC to determine if the main SC is still up and running. If heartbeat interrupts are present, then the `fomd` keeps the spare as spare.

4. The spare `fomd` clears out the checkpoint data on the local disk.

Fault on Main SC (I2 Network Is Also Down)

The following lists the events, in order, that occur after a fault on the main SC.

1. The main `fomd` detects the fault.

If the last known state of the spare SC was good, then the main `fomd` stops generating heartbeats. Otherwise failover does not continue.

If the access to the console bus is still available, main failover software finishes propagating any remaining critical files to HASram and flushes out any or all critical state information to HASram.

2. The main `fomd` reconfigures the SMS software into spare mode.
3. The main `fomd` removes the logical main SC IP address.
4. The main `fomd` stops generating heartbeat interrupts.

Fault Recovery and Reboot

I2 Fault Recovery

The following lists the events, in order, that occur during an I2 network fault recovery.

1. The main `fomd` detects the I2 network is healthy.

If the spare SC is completely healthy as indicated in the health status response message, the `fomd` enables failover and, assuming that the failover mechanism has not been deactivated by the operator, does a complete re-sync of the log files and checkpointing data over to the spare SC.

2. The spare `fomd` detects the I2 network is healthy.

The spare `fomd` disables failover and clears out the checkpoint data on the local disk.

Reboot and Recovery

The following lists the events, in order, that occur during a reboot and recovery. A reboot and recovery scenario happens in the following two cases.

Main SC Receives a Master Reset or Its UltraSPARC® Receives a Reset

1. Assume SSCPOST passed without any problems. If SSCPOST failed and OE cannot be booted, the main is inoperable.

2. Assume all SSC Solaris drivers attached without any problems. If the SBBC driver fails to attach, see [“Fault on Main SC \(Spare Takes Over Main Role\)” on page 194](#), if any other drivers fail to attach, see [“Failover on Main SC \(Main Controlled Failover\)” on page 192](#).
3. The main `fomd` is started.
4. If the `fomd` determines that the remote SC has already assumed the main role, then see Number 5 in [“Spare SC Receives a Master Reset or Its UltraSPARC Receives a Reset” on page 196](#). Otherwise proceed to Number 5 in this list.
5. The `fomd` configures the logical main IP address and starts up the rest of the SMS software.
6. SMS daemons start in recovery mode if necessary.
7. Main `fomd` starts generating heartbeat interrupts.
8. At this point, the main SC is fully recovered.

Spare SC Receives a Master Reset or Its UltraSPARC Receives a Reset

1. Assume SSCPOST passed without any problems. If SSCPOST failed and OE cannot be booted, the spare is inoperable.
2. Assume all SSC Solaris drivers attached without any problems. If the SBBC driver fails to attach, or any other drivers fail to attach, the spare SC is deemed inoperable.
3. The `fomd` is started.
4. The `fomd` determines that the SC is the preferred spare and assumes spare role.
5. The `fomd` starts checking for the presence of heartbeat interrupts from the remote (initially presumed to be main) SC.

If after a configurable amount of time no heartbeat interrupts are detected, then the failover mechanism state is checked. If enabled and activated, `fomd` initiates a take over. Now refer to Number 5 of [“Main SC Receives a Master Reset or Its UltraSPARC® Receives a Reset” on page 196](#). Otherwise, `fomd` continues monitoring for the presence of heartbeat interrupts and the state of the failover mechanism.
6. The `fomd` starts periodically checking the hardware/software and network interfaces.
7. The `fomd` configures the local main SC IP address.
8. At this point, the spare SC is fully recovered.

Client Failover Recovery

The following lists the events that occur during a client failover recovery. A recovery scenario happens in the following two cases.

Fault on Main SC—Recovering From the Spare SC

Clients with any operations in progress are manually recovered by checkpointing data unless they are non-recurring.

Fault on Main SC (With I2 Network Down)—Recovering From the Spare SC

Since the I2 network is down, all checkpointing data are removed. Clients cannot perform any recovery.

Reboot Main SC (With Spare SC Down)

Same as [“Fault on Main SC—Recovering From the Spare SC”](#) on page 197.

Reboot of Spare SC

No recovery necessary.

Security

All failover specific network traffic (such as health status request/response messages and file propagation packets) are sent *only* over the interconnect network that exists between the two SCs.

Domain Events

Event monitoring periodically checks the domain and hardware status to detect conditions that need to be acted upon. The action taken is determined by the condition and can involve reporting the condition or initiating automated procedures to deal with it. This chapter describes the events that are detected by monitoring and the requirements with respect to actions taken in response to detected events.

This chapter includes the following sections:

- [Message Logging](#)
- [Domain Reboot Events](#)
- [Domain Panic Events](#)
- [Solaris Software Hang Events](#)
- [Hardware Configuration Events](#)
- [Environmental Events](#)
- [Hardware Error Events](#)
- [SC Failure Events](#)

Message Logging

SMS logs all significant events, such as those that require taking actions other than logging or updating user monitoring displays in message files on the SC. Included in the log is information to support subsequent servicing of the hardware or software.

SMS writes log messages for significant hardware events to the platform log file located in `/var/opt/SUNWSMS/adm/platform/messages`.

The actions taken in response to events that crash domain software systems include automatic system recovery (ASR) reboots of all affected domain(s), provided that the domain hardware (or a bootable subset thereof) meets the requirements for safe and correct operation.

SMS logs all significant actions other than logging or updating user monitoring displays taken in response to an event. Log messages for significant domain software events and their response actions are written to the message log file for the affected domain located in `/var/opt/SUNWSMS/adm/domain_id/messages`.

SMS writes log messages to `/var/opt/SUNWSMS/adm/domain_id/messages` for significant hardware events that can visibly affect one or more domains of the affected domain(s).

SMS also logs domain console, syslog, event, post, and dump information and manages `sms_core` files.

Log File Maintenance

SMS software maintains SC-resident copies of logs of all server information that it logs. Use the `showlogs(1M)` command to access log information.

The platform message log file can be accessed only by administrators for the platform using:

```
sc0:sms-user:> showlogs
```

SMS log information relevant to a configured domain can be accessed only by administrators for that domain. SMS maintains separate log files for each domain using:

```
sc0:sms-user:> showlogs -d domain_indicator
```

where:

`-d domain_indicator` Specifies the domain using:

domain_id - ID for a domain. Valid *domain_ids* are A–R and are not case sensitive.

domain_tag - Name assigned to a domain using `addtag(1M)`.

SMS maintains copies of domain `syslog` files on the SC in `/var/opt/SUNWSMS/adm/domain_id/syslog`. `syslog` information can be accessed only by administrators for that domain using:

```
sc0:sms-user:> showlogs -d domain_indicator -s
```

Solaris console output logs are maintained to provide valuable insight into what happened before a domain crashed. Console output is available on the SC for a crashed domain in `/var/opt/SUNWSMS/adm/domain_id/console`. `console` information can be accessed only by administrators for that domain using:

```
sc0:sms-user:> showlogs -d domain_indicator -c
```

XIR state dumps, generated by the `reset` command, can be displayed using `showxirstate`. For more information refer to the `showxirstate` man page.

Domain post logs are for service diagnostic purposes and are not displayed by `showlogs` or any SMS CLI.

The `/var/tmp/sms_core.daemon` files are binaries and not viewable.

The availability of various log files on the SC supports analysis and correction of problems that prevent a domain or domains from booting. For more information refer to the `showlogs` man page.

Note – Panic dumps for panicked domains are available in the `/var/crash` logs on the domain and not on the SC.

The following table lists the SMS log information types, and their descriptions.

TABLE 11-1 SMS Log Type Information

Type	Description
Firmware versioning	Unsuitable configuration of firmware version at firmware invocation is automatically corrected and logged.
Power-on self test	LED fault; Platform and domain messages detailing why a fault LED was illuminated.
Power control	All power operations are logged.
Power control	Power operations that violate hardware requirements or hardware recommended procedures.
Power control	Use of override to forcibly complete a power operation.

TABLE 11-1 SMS Log Type Information (*Continued*)

Type	Description
Domain console	Automatic logging of console output to a standard file.
Hardware configuration	Part numbers are used to identify board type in message logs.
Fault and error event monitoring and actions	All list of fault events or error reports written to the event log.
Event monitoring and actions	All significant environmental events (those that require taking action).
Event monitoring and actions	All significant actions taken in response to environmental events.
Domain event monitoring and actions	All significant domain software events and their response actions.
Event monitoring and actions	Significant hardware events written to the platform log.
Event monitoring and actions	All significant clock input failures, clock input switch failures, and loss or gain of phase lock.
Domain event monitoring and actions	Significant hardware events that visibly affect one or more domains are written to the domain(s) log.
Domain boot initiation	Initiation of each boot and the passage through each significant stage of booting a domain is written to the domain log.
Domain boot failure	Boot failures are logged to the domain log.
Domain boot failures	All ASR recovery attempts are logged to the domain log.
Domain panic	Domain panics are logged to the domain log.
Domain panic	All ASR recovery attempts are logged to the domain log.
Domain panic hang	Each occurrence of a domain hang and its accompanying information is logged to the domain log.
Domain panic	All ASR recovery attempts after a domain panic and hang are logged to the domain log.
Repeated domain panic	All ASR recovery attempts after repeated domain panics are logged to the domain message log.
Solaris OS hang events	All operating environment hang events are logged to the domain message log.

TABLE 11-1 SMS Log Type Information (*Continued*)

Type	Description
Solaris OS hang events	All operating environment hang events result in a domain panic in order to obtain a core image for analysis of the Solaris hang. This information and subsequent recovery action is logged to the domain message log.
Solaris OS hang events	SMS monitors for the inability of the domain software to satisfy the request to panic. Upon determining noncompliance with the panic request, SMS aborts the domain and initiates an ASR reboot. All subsequent recovery action is logged to the domain message file.
Hot-plug events	All HPU insertion events of system boards to a domain are logged in the domain message log.
Hot-unplug events	All HPU removals are logged to the platform message log.
Hot-unplug events	All HPU removals from a domain are logged to the domain message log.
POST-initiated configuration events	All POST-initiated hardware configuration changes are logged in <code>/var/opt/SUNWSMS/adm/domain_id/post</code> .
Environmental events	All sensor measurements outside of acceptable operational limits are logged as environmental events to the platform log file.
Environmental events	All environmental events that affect one or more domains are logged to the domain message log.
Environmental events	Significant actions taken in response to environmental events are logged to the platform message log.
Environmental events	Significant actions taken in response to environmental events within a domain are logged to the domain message log.
Hardware error events	Hardware error and related information is logged to the platform message log.
Hardware error events	Hardware error and related information within a domain is logged to the domain message file.
Hardware error events	Log entries about hardware error for which data was collected include the name of the data file(s).
Hardware error events	All significant actions taken in response to hardware error events are logged to the platform message log.
Hardware error events	All significant actions taken in response to hardware error events affecting a domain(s) are logged to the domain(s) message log.
SC failure events	All SC hardware failure and related information is logged to the platform message log.
SC failure events	The occurrence of an SC failover event is logged to the platform message log.

Log File Management

SMS manages the log files, as necessary, to keep the SC disk utilization within acceptable limits.

The message log daemon (`mld`) monitors message log size, file count *per directory*, and age every 10 minutes. `mld` executes the first limit to be reached.

TABLE 11-2 MLD Default Settings

	File Size (in Kb)	File Count	Days to Keep
SMI event log	2500	10	0
Platform messages	2500	10	0
Domain messages	2500	10	0
Domain console	2500	10	0
Domain syslog	2500	10	0
Domain post	20000*	1000	0
Domain dump	20000*	1000	0
<code>sms_core.daemon</code>	100000	20	0

* total per directory not file

Assuming 20 directories, the defaults represent approximately 4Gbytes of stored logs.



Caution – The parameters shown above are stored in `/etc/opt/SUNWSMS/config/mld_tuning`. For any changes to take effect, `mld` must be stopped and restarted. Only an administrator experienced with system disk utilization should edit this file. Improperly changing the parameters in this file could flood the disk and hang or crash the SC.

- When a log message file reaches the size limit `mld` does the following:
Starting with the oldest message file `x.X`, it moves that file to `x.X+1`, except when the oldest message file is `message.9` or core file is `sms_core.daemon.1`, then it starts with `x.X-1`.
For example, `messages` becomes `messages.0`, `message.0` becomes `messages.1` and so on up to `messages.9`. When `messages` reaches 2.5MB then `messages.9` is deleted and all files are bumped up by one and a new empty `messages` file is created.
- When a log file reaches the file count limit `mld` does the following:

When `messages` or `sms_core.daemon` reaches its count limit, then the oldest message or core file is deleted.

- When a log file reaches the age limit `mld` does the following:
- When any message file reaches `x` days, it is deleted.

Note – By default, the age limit (`*_log_keep_days`) is set to zero and not used.

- When a `postdate.time.sec.log` or a `dump_name.date.time.sec` file reaches the file size, count, or age limit, `mld` deletes the oldest file in the directory.

Note – Post files are provided for service diagnostic purposes and not intended for display.

For more information, refer to the `mld` and `showlogs` man pages, and see [“Message Logging Daemon” on page 49](#).

Domain Reboot Events

SMS monitors domain software status (see [“Software Status” on page 169](#)) to detect domain reboot events.

Domain Reboot Initiation

Since the domain software is incapable of rebooting itself, SMS software controls the initial sequence for all domain reboots. In consequence, SMS is always aware of domain reboot initiation events.

SMS software logs the initiation of each reboot and the passage through each significant stage of booting a domain to the domain-specific log file.

Domain Boot Failure

SMS software detects all domain reboot failures.

Upon detecting a domain reboot failure, SMS logs the reboot failure event to the domain-specific message log.

SC resident per-domain log files are available for failure analysis. In addition to the reboot failure logs, SMS can maintain duplicates of important domain-resident logs and transcripts of domain console output on the SC as described in [“Log File Maintenance” on page 200](#).

Domain reboot failures are handled as follows:

- The response to `reboot` or `reset` requests is always a fast bringup procedure.
- The first attempt to recover a domain from software failure uses a quick reboot procedure.
- The first attempt to recover domain from hardware failure uses the `reboot` procedure. The POST default diagnostic level is used in the `reboot` procedure.
- If the domain recovery fails during the POST run, `dsmd` retries POST at the default diagnostic level for up to six consecutive domain recovery failures after the first recovery attempt fails.
- If the domain recovery fails during the IOSRAM layout, OpenBoot PROM download and jump, OpenBoot PROM run, or Solaris software boot, `dsmd` reruns POST at the default diagnostic level. For subsequent failures of this type, for each recovery, `dsmd` runs POST at a test diagnostic level higher than the previous level. `dsmd` retries domain recovery domain at the default level for up to six attempts after the first recovery attempt fails. (All in all, `dsmd` tries domain recovery attempts at most seven times).
- Once the system has been recovered and Solaris software has been booted, any domain failures within four hours is treated as repeated domain failure and is recovered by running POST at higher diagnostic level.
- If there are no domain failures within four hours of Solaris software running, then the domain is considered successfully recovered and healthy.

A subsequent domain hardware failure is handled by the `reboot` procedure.

A subsequent domain software failure is handled by quick reboot procedure, and the `reboot` or `reset` request is handled by the fast bringup procedure.

SMS tries all ASR methods at its disposal to boot a domain that has failed booting. All recovery attempts are logged in the domain-specific message log.

Domain Panic Events

When a domain panics, it informs `dsmd` so that a recovery reboot can be initiated. The panic is reported as a domain software status change (see [“Software Status” on page 169](#)).

Domain Panic

`dsmd` is informed when the Solaris software on a domain panics.

Upon detecting a domain panic, `dsmd` logs the panic event to the domain-specific message log.

SC resident per-domain log files are available to assist in domain panic analysis. In addition to the panic logs, SMS can maintain duplicates of important domain-resident logs and transcripts of domain console output on the SC as described in [“Log File Maintenance” on page 200](#).

In general, after an initial panic where there has been no prior indication of hardware errors, SMS requests that a fast reboot be tried to bring up the domain. For more information, see [“Fast Boot” on page 145](#).

`dsmd` handles a panic event as follows:

- If the domain recovery fails during the POST run, `dsmd` retries POST at the default diagnostic level for up to six consecutive domain recovery failures after the first recovery attempt fails.
- If the domain recovery fails during the IOSRAM layout, OpenBoot PROM download and jump, OpenBoot PROM run, or Solaris software boot, `dsmd` reruns POST at the default diagnostic level. For subsequent failures of this type, for each recovery, `dsmd` runs POST at a test diagnostic level higher than the previous level. `dsmd` retries domain recovery domain at the default level for up to six attempts after the first recovery attempt fails. (All in all, `dsmd` tries domain recovery attempts at most seven times).
- Once the system has been recovered and Solaris software has been booted, any domain failures within four hours is treated as repeated domain failure and is recovered by running POST at higher diagnostic level.
- If there are no domain failures within four hours of Solaris software running, then the domain is considered successfully recovered and healthy.

A subsequent domain hardware failure is handled by the `reboot` procedure.

A subsequent domain software failure is handled by quick reboot procedure, and the `reboot` or `reset` request is handled by the fast bringup procedure.

This recovery action is logged in the domain-specific message log.

Domain Panic Hang

The Solaris panic dump logic has been redesigned to minimize the possibility of hangs at panic time. In a panic situation, Solaris software may operate differently either because normal functions are shut down or because it is disabled by the panic. An ASR reboot of a panicked Solaris domain is eventually started, even if the panicked domain hangs before it can request a reboot.

Since the normal heartbeat monitoring (see [“Solaris Software Hang Events”](#) on page 208) of a panicked domain may not be appropriate or sufficient to detect situations where a panicked Solaris domain will not proceed to request an ASR reboot, `dsmd` takes special measures as necessary to detect a domain panic hang event.

Upon detecting a panic hang event, `dsmd` logs each occurrence including information, to the domain-specific message log.

Upon detection of a domain panic hang (if any), SMS aborts the domain panic (see [“Domain Abort/Reset”](#) on page 146) and initiates an ASR reboot of the domain. `dsmd` logs these recovery actions in the domain-specific message log.

SC resident log files are available to assist in panic hang analysis. In addition to the panic hang event logs, `dsmd` maintains duplicates of important domain-resident logs and transcripts of domain console output on the SC as described in [“Log File Maintenance”](#) on page 200.

Repeated Domain Panic

If a second domain panic is detected shortly after recovering from a panic event, `dsmd` classifies the domain panic as a repeated domain panic event.

In addition to the standard logging actions that occur for any panic, the following action is taken when attempting to reboot after the repeated domain panic event.

With each successive repeated domain panic event, SMS attempts to run POST at a higher diagnostic test level to boot against the next untried administrator-specified degraded configuration (see [“Degraded Configuration Preferences”](#) on page 99).

After all degraded configurations have been tried, successive repeated domain panic events will continue full-test-level boots using the last specified degraded configuration.

Upon determining that a repeated domain panic event has occurred, `dsmd` tries the ASR method at its disposal to boot a stable domain software environment. `dsmd` logs all recovery attempts in the domain-specific message log.

Solaris Software Hang Events

`dsmd` monitors the Solaris heartbeat described in [“Solaris Software Heartbeat”](#) on page 173 in each domain while Solaris software is running (see [“Software Status”](#) on page 169). When the heartbeat indicator is not updated for a period of time, a Solaris software hang event occurs.

dsmd detects Solaris software hangs.

Upon detecting a Solaris hang, dsmd logs the hang event including information, to the domain-specific message log.

Upon detecting a Solaris hang, dsmd requests the domain software to panic in order to obtain a core image for analysis of the Solaris hang (“[Domain Abort/Reset](#)” on [page 146](#)). SMS logs this recovery action in the domain-specific message log.

dsmd monitors the inability of the domain software to satisfy the request to panic. Upon determining noncompliance with the panic request, dsmd aborts the domain (see “[Domain Abort/Reset](#)” on [page 146](#)) and initiates an ASR reboot. dsmd logs these recovery actions in the domain-specific message log.

Although the core image taken as a result of the panic is only available for analysis from the domain, SC resident log files are available to assist in domain hang analysis. In addition to the Solaris hang event logs, dsmd can maintain duplicates of important domain-resident logs and transcripts of domain console output on the SC.

Hardware Configuration Events

Changes to the hardware configuration status are considered hardware configuration events. esmd detects the following hardware configuration events on a Sun Fire high-end system.

Hot-Plug Events

The insertion of a hot-pluggable unit (HPU) is a hot-plug event. The following actions take place:

- SMS detects HPU insertion events and logs each event and additional information to a platform message log file.
- If the inserted HPU is a system board in the logical configuration for a domain, SMS also logs its arrival in the domain’s message log file.

Hot-Unplug Events

The removal of a hot-pluggable unit (HPU) is a hot-unplug event. The following actions take place:

- Upon occurrence of a hot-unplug event, SMS makes a log entry recording the removal of the HPU to the platform message log file.

- A hot unplug event that detects the removal of a system board from a logical domain configuration logs it to that domain's message log file.

POST-Initiated Configuration Events

POST can run against different server components at different times due to domain-related events such as reboots and dynamic reconfigurations. As described in [“Hardware Configuration” on page 174](#), SMS includes status from POST and identifying failed-test components. Consequently, changes in POST status of a component are considered to be hardware configuration events. SMS logs POST-initiated hardware configuration changes to the platform message log.

Environmental Events

In general, environmental events are detected when hardware status measurements exceed normal operational limits. Acceptable operational limits depend upon the hardware and the server configuration.

`esmd` verifies that measurements returned by each sensor are within acceptable operational limits. `esmd` logs all sensor measurements outside of acceptable operational limits as environmental events to the platform log file.

`esmd` also logs significant actions taken in response to an environmental event (such as those beyond logging information or updating user displays) to the platform log file.

`esmd` logs significant environmental event response actions that affect one or more domain(s) to the log file(s) of the affected domain(s).

`esmd` handles environmental events by removing from operation the hardware that has experienced the event (and any other hardware dependent upon the disabled component). Hardware can be left in service, however, if continued operation of the hardware will not harm the hardware or cause hardware functional errors.

The options for handling environmental events are dependent upon the characteristics of the event. All events have a time frame during which the event must be handled. Some events kill the domain software; some do not. Event response actions are such that `esmd` responds within the event time frame.

There are a number of responses `esmd` can make to environmental events, such as increasing fan speeds. In response to a detected environmental event, which requires a power off, `esmd` undertakes one of the following corrective actions:

- `esmd` uses immediate power off if there is no other option that meets the time constraints.
- If the environment event does not require immediate power off and the component is a MaxCPU board, `esmd` attempts to DR the endangered board out of the running domain and power it off.
- If the environment event does not require immediate power off and the component is a centerplane support board (CSB), `esmd` attempts to reconfigure the bus traffic to use only the other CSB and power the component off.
- Where possible, if the environment event does not require immediate power off and the component is any type of board other than a MaxCPU or CSB, `esmd` notifies `dsmd` of the environment condition and `dsmd` sends an "orderly shutdown" request to the domain. The domain flushes uncommitted memory buffers to physical storage.

If the software is still running and a viable domain configuration remains after the affected hardware is removed, `dsmd` will attempt to recover the domain.

If either of the last two options takes longer than the allotted time for the given environmental condition, `esmd` immediately powers off the component regardless of the state of the domain software.

SMS illuminates the fault indicator LED on any hot-pluggable unit that can be identified as the cause of an environmental event.

So long as the environmental event response actions do not include shutdown of the system controller(s), all domain(s) whose software operations were terminated by an environmental event or the ensuing response actions are subject to ASR reboot as soon as possible.

ASR reboot begins immediately if there is a bootable set of hardware that can be operated in accordance with constraints imposed by the Sun Fire high-end system to assure safe and correct operation.

Note – Loss of system controller operation (for example, by the requirement to power both SCs down) eliminates all possibility of Sun Fire high-end platform self-recovery actions being taken. In this situation, some recovery actions can require human intervention. So although an external monitoring agent may not be able to recover the Sun Fire high-end platform operation, that monitoring agent may serve an important role in notifying an administrator about the Sun Fire high-end platform shutdown.

The following sections provide a little more detail about each type of environmental event that can occur on an Sun Fire high-end system.

Over-Temperature Events

esmd monitors temperature measurements from Sun Fire high-end systems hardware for values that are too high. There is a critical temperature threshold that, if exceeded, is handled as quickly as possible by powering off the affected hardware. High, but not critical, temperatures are handled by attempting slower recovery actions such as a graceful shutdown or DR for the MCPUs boards.

Power Failure Events

There is very little opportunity to do anything when a full power failure occurs. The entire platform, domains as well as SCs, are shut off when the plug is pulled without the benefit of a graceful shut down. The ultimate recovery action occurs when power is restored (see [“Power-On Self-Test \(POST\)” on page 147](#)).

Out-of-Range Voltage Events

Power voltages for Sun Fire high-end systems are monitored to detect out-of-range events. The handling of out-of-range voltages follows the general principles outlined at the beginning of [“Environmental Events” on page 210](#).

Under-Power Events

In addition to checking for adequate power before powering on any boards, as mentioned in [“Power Control” on page 153](#), the failure of a power supply could leave the server inadequately powered. The system is equipped with power supply redundancy in the event of failure. esmd does not take any action (other than logging) in response to a bulk power supply hardware failure. The handling of under power events follows the general principles outlined at the beginning of [“Environmental Events” on page 210](#).

Fan Failure Events

esmd monitors fans for continuing operation. Should a fan fail, a fan failure event occurs. The handling of fan-failures follows the general principles outlined at the beginning of [“Environmental Events” on page 210](#).

Clock Failure Events

esmd monitors clocks for continuing operation. Should a clock fail, esmd logs a message every 10 minutes. It also turns on manual override so the clock selector on that board never automatically starts using that clock. If the clock returns to good status, esmd turns off manual override and logs a message.

When phase lock is lost esmd turns on manual override on all the boards and logs one message. When phase lock is back, esmd turns off manual override on all the boards and logs a message.

Hardware Error Events

As described in [“Hardware Error Status” on page 175](#), the occurrence of Sun Fire high-end system hardware errors is recognized at the SC by more than one mechanism. Of the errors that are directly visible to the SC, some are reported directly by PCI interrupt to the UltraSPARC III processor on the SC, and others are detected only through monitoring of the hardware registers on Sun Fire high-end systems.

There are other hardware errors that are detected by the processors running in a domain. Domain software running in the domain detects the occurrence of those errors in the domain, which then reports the error to the SC. Like the mechanism by which the SC becomes aware of the occurrence of a hardware error, the error state retained by the hardware after a hardware error is dependent upon the specific error.

dsmd performs the following functions:

- Implements the mechanisms necessary to detect all SC-visible hardware errors.
- Implements domain software interfaces to accept reports of domain-detected hardware errors.
- Collects hardware error data and clears the error state.
- Logs the hardware error and related information as required, to the platform message log.
- Logs the hardware error to the domain message log file for all affected domain(s).

If data collected in response to a hardware error is not suitable for inclusion in a log file, the data can be saved in uniquely named file(s) in `/var/opt/SUNWSMS/adm/domain_id/dump` on the SC.

SMS illuminates the fault indicator LED on any hot-pluggable unit that can be identified as the cause of a hardware error.

The actions taken in response to hardware errors (other than collecting and logging information as described above) are twofold. First, it may be possible to eliminate the further occurrence of certain types of hardware errors by eliminating from use the hardware identified to be at fault.

Second, all domains that crashed either as a result of a hardware error or were shut down as a consequence of the first type of action are subject to ASR reboot actions.

Note – Even in the absence of actions to remove from use hardware identified to be at fault, the ASR reboot actions are subject to full POST verification. POST eliminates any hardware components that fail testing from the hardware configuration.

In response to each detected hardware error and each domain-software-reported hardware error, `dsmd` undertakes the appropriate corrective actions. In some cases automatic diagnosis and domain recovery will occur (see [Chapter 5](#)), while in other instances, an ASR reboot with full POST verification may be initiated for each domain brought down by a hardware error.

Note – Problems with the ASR reboot of a domain after a hardware error are detected as domain boot failure events and subject to the recovery actions described in [“Domain Boot Failure” on page 205](#).

`dsmd` logs all significant actions, such as those beyond logging information or updating user displays taken in response to a hardware error in the platform log file. When a hardware error affects one or more domains, `dsmd` logs the significant response actions in the message log files of the affected domain(s).

The following sections summarize the types of hardware errors expected to be detected and handled on a Sun Fire high-end system.

Domain Stop Events

Domain stops are uncorrectable hardware errors that immediately terminate the affected domain(s). Hardware state dumps are taken before `dsmd` initiates an ASR reboot of the affected domain(s). These files are located in

`/var/opt/SUNWSMS/adm/domain_id/dump`

`dsmd` logs the event in the domain message log file and also the event log file.

CPU-Detected Events

A RED_state or Watchdog reset traps to low-level domain software (OpenBoot PROM or kadb), which reports the error and requests initiation of ASR reboot of the domain.

An XIR signal (`reset -x`) also traps to low-level domain software (OpenBoot PROM or kadb), which retains control of the software. The domain must be rebooted manually.

Record Stop Events

Correctable data transmission errors (for example, CE ECC errors) can stop the normal transaction history recording feature of ASICs in Sun Fire high-end systems. SMS reports a transmission error as a record stop. SMS dumps the transaction history buffers of these ASICs and re-enables transaction history recording when a record stop is handled. `dsmd` records record stops in the domain log file.

Other ASIC Failure Events

ASIC-detected hardware failures other than domain stop or record stop include console bus errors which may or may not impact a domain. The hardware itself does not abort any domain but the domain software might not survive the impact of the hardware failure and may panic or hang. `dsmd` logs the event in the domain log file.

SC Failure Events

SMS monitors the main SC hardware and running software status as well as the hardware and running software of the spare SC, if present. In a high-availability SC configuration, SMS handles failures of the hardware or software on the main SC or failures detected in the hardware control paths (for example, console bus, or internal network connections) to the main SC by an automatic SC failover process. This cedes main responsibilities to the spare SC and leaves the former main SC as a (possibly crippled) spare.

SMS monitors the hardware of the main and spare SCs for failures.

SMS logs the hardware failure and related information to the platform message log.

SMS illuminates the fault indicator LED on a system controller with an identified hardware failure.

For more information, see [“SC Failover” on page 179](#).

SMS Utilities

This section discusses the SMS backup, configuration, restore, and version utilities. For information and examples of these utilities, refer to the *System Management Services (SMS) 1.4 Reference Manual* and online man pages.

This chapter includes the following sections:

- [SMS Backup Utility](#)
- [SMS Restore Utility](#)
- [SMS Version Utility](#)
- [SMS Configuration Utility](#)

SMS Backup Utility

`smsbackup` creates a `cpio(1)` archive of files that maintain the operational environment of SMS.

Note – This utility runs on the SC and does not replace the need for routine and timely backups of SC and domain operating systems; and domain application data.

Whenever changes are made to the SMS environment, for example, by adding boards to or removing boards from a domain, you must run `smsbackup` again in order to maintain a current backup file for the system controller.

The name of the backup file is `smsbackup.X.X.cpio` - where `X.X` represents the active version from which the backup was taken.

`smsbackup` saves all configuration, platform configuration database, SMS, and log files. In other words, SMS saves everything needed to return SMS to the working state it was in at the time the backup was made.

Backups are *not* performed automatically. Whenever changes are made to the SMS environment, a backup should be performed. This process can be automated by making it part of `root cron` job run at periodic intervals depending on your site requirements.

The backup log file resides in `/var/sadm/system/logs/smsbackup`. You must specify the target location when running `smsbackup`.

Note – The target location must be a valid UFS file system directory. You cannot perform `smsbackup` to a `tmp` file system directory.

Whenever you run `smsbackup`, you receive confirmation that it succeeded or be notified that it failed.

You must have superuser privileges to run `smsbackup`. For more information and examples, refer to the `smsbackup` man page.

Restore SMS backup files using the `smsrestore(1M)` command.

SMS Restore Utility

`smsrestore` restores the operational environment of the SMS from a backup file created by `smsbackup(1M)`. You can use `smsrestore` to restore the SMS environment after the SMS software has been installed on a new disk or after hardware replacement or addition. Failover should be disabled and SMS stopped before `smsrestore` is performed. Refer to the “Stopping and Starting SMS” section of the *System Management Services (SMS) 1.4 Installation Guide*.

If any errors occur, `smsrestore` writes error messages to `/var/sadm/system/logs/smsrestore`.

Note – This utility runs on the SC and does not restore SC operating system, domain operating system or domain application data.

`smsrestore` cannot restore what you have not backed up. Whenever changes are made to the SMS environment, for example, by shutting down a domain, you must run `smsbackup` in order to maintain a current backup file for the system controller.

You must have superuser privileges to run `smsrestore`. For more information and examples, refer to the `smsrestore` man page.

SMS Version Utility

`smsversion(1M)` administers adjacent, co-resident installations of SMS under the same operating environment. Adjacent meaning you can use `smsversion` to switch between version SMS1.1 and SMS1.2 or SMS 1.2 and SMS 1.3 (assuming all are installed), but you cannot use `smsversion` to switch between SMS1.1 and SMS 1.3.

When you switch between sequential releases of SMS (for example, 1.3 to 1.2), SMS must be stopped before running `smsversion`. Refer to “Stopping and Starting SMS” in the *System Management Services (SMS) 1.4 Installation Guide*. `smsversion` backs up important system and domain information and switches to the target SMS version.

You can switch back to the next sequential SMS version (for example, 1.2 to 1.3) at a later time. `smsversion` permits two-way SMS version-switching between sequential co-resident installations on the same operating environment but with the following understanding:

Condition	Explanation
New features	The features supported in the newer version of SMS may not be supported in the older version, for example COD. Switching to an older version of SMS can result in the loss of those features. Also, the settings for the new features might be erased.
Flash PROM differences	Switching versions of SMS requires reflashing the CPU flash PROMs with the correct files. These files can be found in the <code>/opt/SUNWSMS/<SMS_version>/firmware</code> directory. Use <code>flashupdate(1M)</code> to reflash the PROMs after you have switched versions. Refer to the <code>flashupdate</code> man page and <i>System Management Services (SMS) 1.4 Installation Guide</i> for more information on updating flash PROMs.

Note – Switching between non-sequential releases is *not* supported. Switching between sequential SMS versions across Solaris operating environments (for example, Solaris 8 and Solaris 9) is *not* supported. Once you upgrade from Solaris 8: SMS 1.1, SMS 1.2 or SMS 1.3 to Solaris 9: SMS 1.3 you cannot go back without also re-installing the earlier operating system version.

Without options, `smsversion` displays the active version and exits when only one version of SMS is installed.

If any errors occur, `smsversion` writes error messages to `/var/sadm/system/logs/smsversion`.

You must have superuser privileges to run `smsversion`. For more information and examples, refer to the `smsversion` man page.

Version Switching

▼ To Switch Between Two Adjacent, Co-resident Installations of SMS

On the Main SC:

1. **Make certain your configuration is stable and backed up using `smsbackup`.**

Being stable means the following commands should *not* be running: `smsconfig`, `poweron`, `poweroff`, `setkeyswitch`, `cfgadm`, `rcfgadm`, `addtag`, `deletetag`, `addboard`, `moveboard`, `deleteboard`, `setbus`, `setdefaults`, `setobpparams`, `setupplatform`, `enablecomponent`, or `disablecomponent`.

2. **Deactivate failover using `setfailover off`.**

On the Spare SC:

3. **Run `/etc/init.d/sms stop`.**

4. **Run `smsversion`.**

5. **Run `smsrestore`.**

6. **If necessary, run `smsconfig -mand reboot`.**

Only run `smsconfig -m` if you changed your network configuration using `smsconfig -m` *after* creating the `smsbackup` you just restored.

On the Main SC:

7. **Stop SMS using `/etc/init.d/sms stop`.**

On the Spare SC:

8. **If `smsconfig -m` was run, reboot otherwise run `/etc/init.d/sms start`.**

When the SC comes up, it becomes the main SC.

9. **If necessary, update the CPU flash PROMs using `flashupdate`.**

On the Former Main SC:

1. **Repeat steps 4-6 and 8.**

On the New Main SC:

1. **Activate failover using** `setfailover on`.

For more information refer to the *System Management Services (SMS) 1.4 Installation Guide*.

SMS Configuration Utility

`smsconfig` configures the MAN networks, modifies the hostname and IP address settings used by the MAN daemon, `mand(1M)` and administers domain directories access control lists (ACLs). It will also display the current configuration.

UNIX Groups

`smsconfig` configures the UNIX groups used by SMS to describe user privileges. SMS uses a default set of UNIX groups installed locally on each SC. `smsconfig` allows you to customize those groups using the `-g` option. `smsconfig` allows you to add users to groups using the `-a` option and remove users from groups using the `-r` option.

For information and examples on adding, removing, and listing authorized users, refer to the *System Management Services (SMS) 1.4 Installation Guide* and the `smsconfig(1M)` man page.

Access Control List (ACL)

Traditional UNIX file protection provides read, write, and execute permissions for the three user classes: file owner, file group, and other. In order to provide protection and isolation of domain information, access to each domain's data is denied to all unauthorized users. SMS daemons, however, are considered authorized users and will have full access to the domain file systems. For example:

- `sms-esmd`—needs to read the blacklist files in each domain directory
`$SMSETC/config/[A-R]`
- `sms-osd`—needs to read from and write to the `bootparamdata` file in each domain: `$SMSVAR/data/[A-R]`
- `sms-dsmd`—needs to write to `hpost` logs for every domain
`$SMSVAR/adm/[A-R]/post`

`smsconfig` sets the ACL entries associated with the domain directories so that the domain administrator has full access to the domain. A plus sign (+) to the right of the mode field indicates the directories that have ACL defined.

```
domain_id:sms-user:> ls -al
total 6
drwxrwxrwx  2 root    bin           512 May 10 12:29 .
drwxrwxr-x 23 root    bin          1024 May 10 12:29 ..
-rw-rw-r--+ 1 root    bin           312 May  4 16:15 blacklist
```

To add a user account to the ACL, the user must already belong to a valid SMS group as described in the *System Management Services (SMS) 1.4 Installation Guide*.

Note – UFS file system attributes, such as the ACL, are supported in UFS file systems only. If you restore or copy directories with ACL entries into the `/tmp` directory, all ACL entries will be lost. Use the `/var/tmp` directory for temporary storage of UFS files and directories.

Network Configuration

For each network, `smsconfig` can singularly set one or more *interface* designations within that network. By default, `smsconfig` steps through the configuration of all three internal, enterprise networks.

To configure an individual network, append the *net_id* to the command line. Management networks *net_ids* are designated I1, I2, and C.

Configure a single domain within an enterprise network by specifying both the desired domain and its *net_id*. A domain can be excluded from the I1 management network by using the word `NONE` as the MAN *hostname*.

Note – Once you have configured or changed the configuration of the MAN network you *must* reboot the SC in order for the changes to take effect.

You must have superuser privileges to run `smsconfig`. For more information and examples, refer to the *System Management Services (SMS) 1.4 Installation Guide*, `smsconfig` man page and see [“Management Network Services” on page 165](#).

MAN Configuration

`smsconfig -m` does the following:

1. Creates `/etc/hostname.scman[01]`.
2. Creates `/etc/hostname.hme0` and/or `/etc/hostname.eri1` according to inputs to the External Network(s) prompts of `smsconfig`.
3. Updates `/etc/netmasks` and `/etc/hosts`.
4. Sets OpenBoot PROM variable `local-mac-address?=true` (default is false).

For more information on `smsconfig` refer to the `smsconfig(1M)` man page and see [“Management Network Services” on page 165](#).

SMS man Pages

The SMS man pages are in the *System Management Services (SMS) 1.4 Reference Manual* portion of your Sun Fire high-end system documentation set as well as online (after you have installed the SMS packages.)

The following is a list of SMS man pages:

- `addboard(1M)` - Assigns, connects, and configures a board to a domain.
- `addcodlicense(1M)` - Adds a Capacity on Demand (COD) right-to-use (RTU) license key to the COD license database.
- `addtag(1M)` - Assigns a domain name (tag) to a domain.
- `cancelcmdsync(1M)` - Removes a command synchronization descriptor from the command synchronization list.
- `codd(1M)` - Capacity on Demand daemon.
- `console(1M)` - Access the domain console.
- `dca(1M)` - Domain configuration agent.
- `deleteboard(1M)` - Unconfigures, disconnects, and unassigns a system board from a domain.
- `deletecodlicense(1M)` - Removes a COD RTU license key from the COD license database.
- `deletetag(1M)` - Removes the domain name (tag) associated with the domain.
- `disablecomponent(1M)` - Adds the specified component from the ASR blacklist.
- `dsmd(1M)` - Domain status monitoring daemon.
- `dxs(1M)` - Domain X server.
- `efhd(1M)` - Error and fault handling daemon.
- `elad(1M)` - Event log access daemon.
- `erd(1M)` - Event reporting daemon.
- `enablecomponent(1M)` - Removes the specified component from the ASR blacklist.
- `esmd(1M)` - Environmental status monitoring daemon.
- `flashupdate(1M)` - Update system board FROMs.
- `fomd(1M)` - Failover management daemon.
- `frad(1M)` - FRU access daemon.
- `help(1M)` - Displays help information for SMS commands.

- `hpost(1M)` - Sun Fire high-end system power-on self test (POST) control application.
- `hwad(1M)` - Hardware access daemon.
- `initcmds(1M)` - Creates a command synchronization descriptor that identifies the script to be recovered.
- `kmd(1M)` - Key management daemon.
- `mand(1M)` - Management network daemon.
- `mld(1M)` - Message logging daemon.
- `moveboard(1M)` - Moves a system board from one domain to another.
- `osd(1M)` - OpenBoot PROM server daemon.
- `pcd(1M)` - Platform configuration database daemon.
- `poweroff(1M)` - Controls power off.
- `poweron(1M)` - Controls power on.
- `rcfgadm(1M)` - Remote configuration administration.
- `reset(1M)` - Sends reset to all ports (CPU or I/O) of a specified domain.
- `resetsc(1M)` - Sends reset to the spare SC.
- `runcmdsync(1M)` - Prepares a specified script for recovery after a failover.
- `savecmds(1M)` - Adds a marker that identifies a location in the script from which processing can be resumed after a failover.
- `setbus(1M)` - Performs dynamic bus reconfiguration on active expanders in a domain.
- `setcsn(1M)` - Sets the chassis serial number for a Sun Fire high-end system.
- `setdatasync(1M)` - Modifies the data propagation list used in data synchronization.
- `setdate(1M)` - Sets the date and time for the system controller or a domain.
- `setdefaults(1M)` - Removes all instances of a previously active domain.
- `setfailover(1M)` - Modifies the state of the SC failover mechanism.
- `setkeyswitch(1M)` - Changes the position of the virtual keyswitch.
- `setobpparams(1M)` - Sets up OpenBoot PROM variables.
- `setupplatform(1M)` - Sets up the available component list for domains.
- `showboards(1M)` - Shows the assignment information and status of the system boards.
- `showbus(1M)` - Displays the bus configuration of expanders in active domains.
- `showcmds(1M)` - Displays the current command synchronization list.
- `showcodlicense(1M)` - Displays the current COD RTU licenses stored in the COD license database.
- `showcodusage(1M)` - Displays the current usage statistics for COD resources.
- `showcomponent(1M)` - Displays ASR blacklist status for a component.
- `showdatasync(1M)` - Displays the status of SMS data synchronization for failover.
- `showdate(1M)` - Displays the date and time for the system controller or a domain.
- `showdevices(1M)` - Displays system board devices and resource usage information.
- `showenvironment(1M)` - Displays the environmental data.
- `showfailover(1M)` - Displays SC failover status or role.
- `showkeyswitch(1M)` - Displays the position of the virtual key switch.

- `showlogs(1M)` - Display message log files, the event logs, or the Event Dictionary Database.
- `showobpparams(1M)` - Displays OpenBoot PROM bringup parameters.
- `showplatform(1M)` - Displays the board available component list for domains.
- `showxirstate(1M)` - Displays cpu dump information after sending a reset pulse to the processors.
- `smsbackup(1M)` - Backs up the SMS environment.
- `smsconfig(1M)` - Configures the SMS environment.
- `smsconnectsc(1M)` - Access a remote SC console.
- `smsrestore(1M)` - Restores the SMS environment.
- `smsversion(1M)` - Displays the active version of SMS software.
- `ssd(1M)` - SMS startup daemon.
- `testemail(1M)` - Test the event-reporting features, which include event message logging and email notification of events.
- `tmd(1M)` - Task management daemon.
- `wcapp(1M)` - wPCI application daemon.

Error Messages

This section discusses user-visible error messages for SMS. The types of errors and the numerical ranges are listed. To view individual errors, you must install the SMSHelp software package (SUNWSMSj_h). This section contains installation instructions for SUNWSMSj_h, if it was not already been installed during the SMS software installation.

Each error in SMSHelp contains the error ID, the text of the message, the meaning of the message, references for further information in the *System Management Services (SMS) 1.4 Administrator Guide* if applicable, and recovery action to take or suggested steps for further analysis.

This chapter includes the following sections:

- [Installing smshelp](#)
- [Types of Errors](#)
- [Error Categories](#)

Installing smshelp

This section explains how to manually install the SUNWSMSj_h package using the standard installation utility, `pkgadd`.

▼ To Install the SUNWSMSj_h Package

1. Log in to the SC as superuser.

2. Load the SUNWSMSjh package on the server:

```
# pkgadd -d . SUNWSMSjh
```

The software briefly displays copyright, trademark, and license information for each package. Then it displays messages about pkgadd(1M) actions taken to install the package, including a list of the files and directories being installed. Depending on your configuration, the following messages may be displayed:

```
This package contains scripts which will be executed  
with superuser permission during the process of installing this  
package.
```

```
Do you want to continue with the installation of this  
package [y,n,?]
```

3. Type *y* at each successive prompt to continue.

When this portion of the installation is complete, the SUNWSMSjh package has been installed and the superuser prompt is displayed.

4. Remove the Sun Computer Systems Supplements CD from the CD-ROM drive, if applicable:

```
# cd /  
# eject cdrom
```

5. Log out as superuser.

▼ To Start smshelp

1. Log in to the SC as a user with platform or domain group privileges.

2. In any terminal window, type:

```
sc0:~sms-user:> smshelp &
```

The smshelp browser appears. You can resize the panes if necessary, by placing your cursor to the right of the vertical scroll bar, pressing the left mouse button, and dragging the cursor to the right.

3. Choose an error message.

Error messages are recorded in the platform and domain logs.

The message format follows the `syslog(3)` convention: (relevant parts of the message are in bold)

```
timestamp host process_name [pid]: [message_code  
high_res_timestamp level source_code_file_name  
source_code_line_num] message_text
```

For example:

```
Feb 2 18:36:14 2002 xc17-sc0 dsmd[117469]-B(): [2517  
16955334989087 WARNING EventHandler.cc 121] Record stop has been  
detected in domain B.
```

Using the `message_code`, you can either do a quick search using the magnifying glass at the top of the browser or you can scroll through the Table of Contents.

To do a quick search, click on the magnifying glass and enter the error message number and press Return as shown in the follow example.

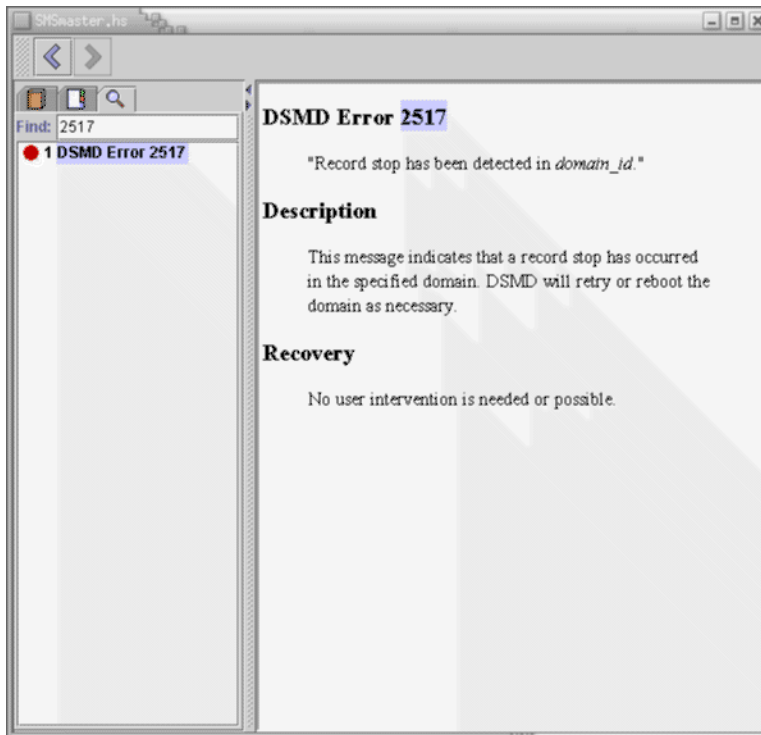

4. To scroll the Table of Contents, left click on the message folder containing your error message, in this case DSMD Error Messages, 2500 through 2599, then left click on error 2517 as shown in the following example.



Types of Errors

This section describes the six types of errors reflected in the error messages in `smshelp`.

TABLE B-1 Error Types

Error	Description
EMERG	Panic conditions that would normally be broadcast to all users.
ALERT	Conditions that should be corrected immediately, such as a corrupted system database.
CRIT	Warnings about critical conditions, such as hard device failures.
ERROR	All other errors.
WARNING	Warning messages.
NOTICE	Conditions that are not error conditions but may require special handling.

Error Categories

The following table shows the different error categories in SMS. Nonsequential numbering is due to error messages reserved for internal or service use.

TABLE B-2 Error Categories

Error Numbers	Message Group
0-499	Reserved for DEBUG, INFO and POST messages
500-699	Reserved for SMS Foundation Library messages
700-899	Reserved for SMS Application Framework messages
900-1099	Reserved for SMSEvent IF Library messages
1100-1299	Reserved for <code>HWAD</code> daemon and library messages
1300-1499	Reserved for <code>ssd</code> messages
1500-1699	Reserved for <code>flashupdate</code> messages
1700-1899	Reserved for <code>pcd</code> messages

TABLE B-2 Error Categories (*Continued*)

Error Numbers	Message Group
1900-2099	Reserved for <code>esmd</code> messages
2500-2699	Reserved for <code>dsmd</code> messages
2700-2899	Reserved for <code>addtag</code> messages
2900-3099	Reserved for <code>deletetag</code> messages
3100-3299	Reserved for Permissions messages
3300-3499	Reserved for <code>domain_tag</code> messages
3500-3699	Reserved for <code>addboard</code> messages
3700-3899	Reserved for <code>tmd</code> messages
4100-4299	Reserved for <code>showkeyswitch</code> messages
4300-4499	Reserved for <code>dca</code> messages
4500-4699	Reserved for <code>libscdr</code> plugin messages
4700-4899	Reserved for <code>osd</code> messages
4900-5099	Reserved for <code>dxs</code> messages
5100-5299	Reserved for <code>deleteboard</code> messages
5300-5499	Reserved for <code>setkeyswitch</code> messages
5500-5699	Reserved for <code>libdrcmd</code> messages
5700-5899	Reserved for <code>moveboard</code> messages
5900-6099	Reserved for <code>setupplatform</code> messages
6100-6299	Reserved for <code>power</code> command messages
6300-6499	Reserved for <code>xir</code> library messages
6500-6699	Reserved for <code>showplatform</code> messages
6700-6899	Reserved for <code>help</code> messages
6900-7099	Reserved for <code>reset</code> messages
7100-7299	Reserved for <code>showboards</code> messages
7300-7499	Reserved for <code>libshowboards</code> messages
7500-7699	Reserved for <code>autolock</code> messages
7700-7899	Reserved for <code>mand</code> messages
7900-8099	Reserved for <code>showenvironment</code> messages
8100-8299	Reserved for <code>resetsc</code> messages
8300-8499	Reserved for dynamic bus reconfiguration messages

TABLE B-2 Error Categories (*Continued*)

Error Numbers	Message Group
8500-8699	Reserved for fcmd messages
8700-8899	Reserved for kmd messages
8900-9099	Reserved for setdefaults messages
9100-9299	Reserved for mld messages
9300-9499	Reserved for showdevices messages
9500-9699	Reserved for showxirstate messages
9700-9899	Reserved for COD messages
9900-10000	Reserved for frad messages
10100-10299	Reserved for fruevent messages
10300-10499	Reserved for smsconnectsc messages
10700-10899	Reserved for EFE messages
11100-11299	Reserved for rcfadm messages
11300-11499	Reserved for datasync messages
50000-50099	Reserved for SMS generic messages

Glossary

A

- ACL** See *access control list (ACL)*.
- access control list (ACL)** Access control list (ACL) provides greater control over file and folder permissions. ACL enables you to define file or folder permissions for the owner, owner's group, others, and specific users and groups, and default permissions for each of these categories.
- active board** A board is considered active when it is in the `connected/unconfigured` state.
- active board list** List of components that are in use in a domain. The `pcd(1M)` keeps the state of this list.
- active domain** A domain running operating system (OS) software.
- ADR** See *Automated dynamic reconfiguration (ADR)*.
- application specific integrated circuit (ASIC)** In the Sun Fire systems, any of the large main chips in the design, including the UltraSPARC processor and data buffer chips.
- arbitration stop** A condition that occurs when one of the Sun Fire high-end system ASICs detects a parity error or equivalent fatal system error. Bus arbitration is frozen, so all bus activity stops.
- ASIC** See *application specific integrated circuit (ASIC)*.

assigned board list List of components that have been assigned to a domain by a domain administrator/configurator privileged user. The `pcd(1M)` keeps the state of this list.

ASR Automatic System Recovery.

auto-failover The process by which the SMS daemon, `fomd`, automatically switches SC control from the main SC to the spare in the event of hardware or software failure on the main.

Automated dynamic reconfiguration (ADR)

The dynamic reconfiguration of system boards accomplished through commands that can be used to automatically `assign/unassign`, `connect/disconnect` and `configure/unconfigure` boards, and obtain board status information. You can run these commands interactively or in shell scripts.

automatic diagnosis engine

A software feature that identifies hardware errors that affect the availability of a platform and its domains.

automatic system recovery (ASR)

Procedures that restore the system to running all properly configured domains after one or more domains have been rendered inactive due to software or hardware failures or due to unacceptable environmental conditions

available component list

List of available components that can be assigned to a domain by a domain administrator/configurator privileged user. The `pcd(1M)` keeps the state of this list. `setupplatform(1M)` updates it.

AXQ An ASIC in a Sun Fire high-end system that is on the expander board.

B

BBC Bootbus controller. An ASIC used on the CPU & I/O boards (also system controller boards), that connects the Bootbus to the PROM bus and the console bus.

BBSRAM See *bootbus SRAM (BBSRAM)*.

blacklist A text file that `hpost(1M)` reads when it starts up. The blacklist file specifies the Sun Fire system components that are not to be used or configured into the system. Platform and domain blacklist files can be edited using the `enablecomponent` and `disablecomponent` commands. The ASR blacklist is created and edited by `esmd`.

bootbus A slow-speed, byte-wide bus controlled by the processor port controller ASICs, used for running diagnostics and boot code. UltraSPARC starts running code from bootbus when it exits reset. In the Sun Fire high-end system, the only component on the bootbus is the BBSRAM.

**bootbus SRAM
(BBSRAM)**

A 256-Kbyte static RAM attached to each processor PC ASIC. Through the PC, it can be accessed for reading and writing from JTAG or the processor. Bootbus SRAM is downloaded at various times with hpost(1M) and OpenBoot PROM startup code, and provides shared data between the downloaded code and the SC.

C

Capacity on Demand

Capacity on Demand (COD) is an option that provides additional processing resources (CPUs) when you need them. These additional CPUs are provided on COD CPU/Memory boards that are installed on Sun Fire high-end systems. You can access the COD CPUs after you purchase the COD right-to-use (RTU) licenses for them.

**cacheable address slice
map (CASM)**

A table in the AXQ that directs cacheable addresses to the correct expander.

CASM

See *cacheable address slice map (CASM)*.

Chassis HostID

The serial number of the centerplane. This number is used only by the COD feature to identify the platform for COD licensing purposes.

chassis serial number

A serial number that identifies a Sun Fire high-end system. The chassis serial number is printed on a label located on the front of the system chassis, near the bottom center. This number is used by your service provider to correlate hardware error events and service actions to the appropriate system.

checkpoint data

A copy of the state an SC client is in at a specific execution point that is periodically saved to disk.

CLI

Command-line interface.

cluster

A cooperative collection of interconnected computer systems, each running a separate OS image, utilized as a single, unified computing resource.

community

An IP network at a customer site that is physically separate from any other networks.

community name

A string identifier that names a particular community. In the context of External Network Monitoring for a Sun Fire high-end system, it is used as the interface group name. See *interface group name*.

- CMR** Coherent Memory Replication.
- cmdsync** Command synchronization. Commands that work together to control recovery during SC failover. For example, `cancelcmdsycn`, `initcmdsycn`, and `savecmdsycn`.
- CPU** Central processing unit.

D

- DARB** An ASIC on the Sun Fire high-end system centerplane that handles data arbitration.
- DARB interrupt** An interrupt of the SC processor initiated by a signal from either or both DARB ASIC on the Sun Fire high-end system centerplane. DARB asserts this interrupt signal in response to three kinds of events: `Dstops`, `Recordstops`, and non-error requests for attention initiated by domain processors writing to a system register in the AXQ ASIC.
- DCU** See *domain configuration unit (DCU)*.
- DHCP** Dynamic Host Configuration Protocol.
- DIMM** See *dual in-line memory module (DIMM)*.
- dstop** See *domain stop*.
- disk array** A collection of disks within a hardware peripheral. The disk array provides access to each of its housed disks through one or two Fibre Channel modules.
- disk array controller** A controller that resides on the host system and has one or two Fibre Channel modules.
- disk array port** A Fibre Channel module that can be connected to a disk array controller that is serviced by a driver pair; for example, `soc/pln` for SSAs.
- domain** A set of one or more system boards that acts as a separate system capable of booting the OS and running independently of any other domains. A machine environment capable of running its own OS. There are up to eighteen domains available on the Sun Fire high-end system. Domains that share a system are characteristically independent of each other.
- domain configuration unit (DCU)** A unit of hardware that can be assigned to a single domain. Domains are configured from DCUs. CPU/Memory, PCI I/O, hsPCI I/O, and hsPCI+ I/O are DCUs. `csb`, `exb` boards, and the SC are not.
- `domain_id` Domain ID of a domain.

<code>domain_tag</code>	Domain name assigned using <code>addtag</code> (1M).
domain stop	An uncorrectable hardware error that immediately terminates the affected domain.
DR	See <i>dynamic reconfiguration (DR)</i> .
DRAM	See <i>dynamic RAM(DRAM)</i> .
drift file	The name of the file used to record the drift (or frequency error) value computed by <code>xntpd</code> . The most common name is <code>ntp.drift</code> .
DSD	Dynamic System Domain. See <code>Domain</code> .
dual in-line memory module (DIMM)	A small printed circuit card containing memory chips and some support logic.
dynamic reconfiguration (DR)	Enables you to logically attach and detach system boards to and from the operating system without causing machine downtime. DR is used in conjunction with <code>hot-swap</code> , which is the process of physically removing or inserting a system board. You can use DR to add a new system board, reinstall a repaired system board, or modify the domain configuration on the Sun Fire system.
dynamic RAM(DRAM)	Hardware memory chips that require periodic rewriting to retain their contents. This process is called “refresh”. In a Sun Fire high-end system, DRAM is used only on main memory SIMMs and on the control boards.



E

ECC	Error Correction Code.
Ecache	See <i>external cache (Ecache)</i> .
EEPROM	Electrically Erasable Programmable Read-Only Memory.
Environmental Monitoring	Systems have a large number of sensors that monitor temperature, voltage, and current. The SC daemons <code>esmd</code> and <code>dsmc</code> poll devices in a timely manner and makes the environmental data available. The SC shuts down various components to prevent damage.
Ethernet address	A unique number assigned to each Ethernet network adapter. It is a 48-bit number maintained by the IEEE. Hardware vendors obtain blocks of numbers that they can build into their cards. See also, <i>MAC address</i> .

- external cache (Ecache)** 8Mbyte synchronous static RAM second-level cache local to each processor module. Used for both code and data. This is a direct-mapped cache.
- external network** A network that requires a physical cable to connect a node to the network. In the context of a Sun Fire high-end system, it is the set of networks connected to the RJ45 jacks located on the front of each Sun Fire high-end system. See [external network interface](#).
- external network interface** One of the RJ45 jacks located on the front of each Sun Fire high-end System Controller.
-

F

- Fibre Channel module** An optical link connection (OLC) module on a disk array controller that can be connected to a disk array port.
- Fireplane** Centerplane in the Sun Fire high-end system.
- FPROM** Flash programmable read-only memory.
- FRU** Field replaceable unit.
-

G

- GDCD** See [global domain configuration descriptor \(GDCD\)](#).
- global domain configuration descriptor (GDCD)** The description of the single configuration that `hpost(1M)` chooses. It is part of the structure handed off to OpenBoot PROM.
- GUI** Graphical user interface.
-

H

- HA** High availability.

HASRAM	High availability SRAM.
headroom	See <i>instant access CPUs</i> .
heartbeat interrupt	Interruption of the normal Solaris operating environment indicator, readable from the SC. Absence of heartbeat updates for a running Solaris system usually indicates a Solaris hang.
hpost	Host POST is the POST code that is executed by the SC. Typically this code is sourced from the SC local disk.
HPCI	Hot-pluggable PCI I/O assembly.
HPU	Hot-Pluggable Unit. A hardware component that can be isolated from a running system such that it can be cleanly removed from the system or added to the system without damaging any hardware or software.
HsPCI	See <i>HPCI</i> .

I

I1 Network	There are 18 network interfaces (NICs) on each SC. These are connected in a point-to-point fashion to NICs located on each of the Sun Fire 15K 18 expander I/O slots or nine are connected on each of the Sun Fire 12K nine expander I/O slots. All of these point-to-point links are collectively called the I1 network.
I²C	Inter-IC Bus. This two-wire bus is used throughout various systems to run LEDs, set system clock resources, read thermal information, and so on.
I2 Network	There is an internal network between the two system controllers consisting of two NICs per system controller. This network is called the I2 network. It is not a private network and is entirely separate from the I1 network.
IDPROM	Identification PROM. Contains information specific to the Sun Fire high-end system internal machine, such as machine type, manufacturing date, Ethernet address, serial number and host ID.
instant access CPUs	Unlicensed COD CPUs on COD CPU/Memory boards installed in Sun Fire high-end systems. You can access up to a maximum of eight COD CPUs for immediate use while you are purchasing the COD right-to-use (RTU) licenses for the COD CPUs. Also referred to as <i>headroom</i> .
interface group	A group of network interfaces that attach to the same community.
interface group name	A string identifier that names a particular interface group. In the context of External Network Monitoring for Sun Fire high-end system, it is the name associated with a particular community.

- ioctl** A control device. This function performs a variety of control functions on devices and STREAMS. For non-STREAMS, the functions performed by this call are device-specific control functions.
- IP link** A communication medium over which nodes communicate at the link layer. The link layer is the layer immediately below IPv4/IPv6. Examples include Ethernets (simple or bridged) or ATM networks.
- IPv4** Internet Protocol version 4.
- IPv6** Internet Protocol version 6. IPv6 increases the address space from 32 to 128 bits. It is backwards compatible with IPv4.
- IOSRAM** Input-Output Static Random-Access Memory.
- IPMP** IP Network Multipathing. Solaris software that provides load spreading and failover for multiple network interface cards connected to the same IP link, for example, Ethernet.
-

J

- JTAG** A serial scan interface specified by IEEE standard 1149.1. The name comes from Joint Test Action Group, which initially designed it.
- JTAG+** An extension of JTAG, developed by Sun Microsystems Inc., which adds a control line to signal that board and ring addresses are being shifted on the serial data line. Often referred to simply as JTAG.
-

K

- kadb** kadb is an interactive kernel debugger with a user interface. For more information refer to the `kadb(1M)` Solaris man page.
-

L

- LCD** Liquid crystal display.
- LED** Light emitting diode.

M

- MAC address** Worldwide unique serial number assigned to a network interface. IEEE controls the distribution of MAC addresses. See also [Ethernet address](#).
- mailbox** See [Mbox](#).
- MAN** SMS Management Network.
- MaxCPU** Dual CPU board.
- Mbox** Message passing mechanism between SMS software on the SC and OpenBoot PROM and the Solaris operating environment on the domain.
- MIB** Management Information Base.
- metadisk** A disk abstraction that provides access to an underlying group of two physical paths to a disk.
- metanetwork** A network abstraction that provides access to an underlying group of two physical paths to a network.

N

- network interface card (NIC)** Network adapter which is either internal or a separate card that serves as an interface to an IP link.
- network time protocol (NTP)** Network Time Protocol. Supports synchronization of Solaris time with the time service provided by a remote host.
- NIC** See [network interface card \(NIC\)](#).
- NIS+** Network Information Service Plus. A secure, hierarchical network naming service.
- no-domain** Describes the state of a board (DCU) that is not assigned to any domain.
- NTP** See [network time protocol \(NTP\)](#).

O

- OBP** See *OpenBoot PROM*.
- OpenBoot PROM** A layer of software that takes control of the configured Sun Fire high-end system from `hpost(1M)`, builds some data structures in memory, and boots the operating system. IEEE 1275-compliant OpenBoot PROM.
- OS** Operating system.
- OSR** Operating system resource.

P

- path group** A set of two alternate paths that provide access to the same device or set of devices.
- physical path** The electrical path from the host to a disk or network.
- platform** A single physical computer.
- POR** Power-on-reset.
- POST** See *power-on self-test (POST)*.
- power-on self-test (POST)** A test performed by `hpost(1M)`. This program takes uninitialized Sun Fire high-end system hardware and probes and tests its components, configures what seems worthwhile into a coherent initialized system, and hands it off to OpenBoot PROM. In the Sun Fire high-end system POST is implemented in a hierarchical manner with the following components: `lpost`, `spost`, and `hpost`.
- PROM** Programmable Read Only Memory.

R

- RAM** Random access memory.
- RARP** Reverse Address Resolution Protocol.
- rstop** See *Record Stop*.

Record Stop A correctable data transmission error.

RPC Remote procedure call.

S

SBBC See [BBC](#).

SC System controller. The Nordica board that assists in monitoring or controlling the system.

SEEPROM Serial EEPROM.

SMP Symmetric multi-processor.

SMS System Management Services software. The software that runs on the Sun Fire high-end system SC and provides control/monitoring functions for the Sun Fire high-end system platform.

SNMP Simple Network Management Protocol.

split-brain condition When both SCs think they are the main SC.

SRAM See [static RAM \(SRAM\)](#).

static RAM (SRAM) Memory chips that retain their contents as long as power is maintained.

System Board For next-generation Sun Fire servers, there are five types of system boards, four of which can be found in the Sun Fire high-end system. The system boards are the CPU/Memory board, the I/O board, the WCI board, the Sun Fire high-end system PCI controller board, and the Sun Fire high-end system compact PCI controller board.

T

TCP/IP Transmission Control Protocol/Internet Protocol.

TOD Time of day.

tunnel switch The process of moving the SC/Domain communications tunnel from one IO board to another in a domain. Typically occurring when a the IO board with the tunnel is being dynamically reconfigured out.

U

URL Uniform Resource Locator.

UltraSPARC The UltraSPARC processor is the processor module used in the Sun Fire high-end system.

V

virtual keyswitch The SC provides a virtual keyswitch for each domain which controls the bringup process for each domain. The `setkeyswitch(1M)` command controls the position of the virtual keyswitch for each domain. Possible positions are: `on`, `off`, `standby`, `diag`, and `secure`.

W

wPCI Sun Fire Link I/O assembly.

X

XIR eXternally Initiated Reset. Sends a “soft” reset to the CPU in a domain. It does not reboot the domain. After receiving the reset, the CPU drops to the OpenBoot PROM prompt.

Index

A

- addboard, 67, 82
- addcodlicense, 126
- adding domains, 67, 82
- addtag, 67
- automatic diagnosis and recovery, 101
 - component health status, 104, 106
 - diagnosis engines, types of, 103, 105, 106
 - domain restoration, 104
 - domains
 - hardware errors, 101
 - email event notification, 103, 107
 - error and fault event reporting, 103, 106
 - event log, 104
 - hardware error detection, 102, 105, 106
 - resource deconfiguration, 106
- available component list, 65

B

- blacklist
 - platform and domain, 148, 152

C

- cancelcmdsync, 189
- Capacity on Demand (COD), 121
 - Chassis HostID, 52, 131, 140
 - instant access CPUs (headroom), 123
 - prerequisites, 124
 - resources

- configuring, 128
- CPU status, 135, 139
 - monitoring, 124, 132, 134
- right-to-use (RTU) licenses, 122
 - allocation, 123
 - certificates, 122
 - keys, 125, 127
 - obtaining, 125
- Chassis HostID, 52, 131, 140
- chassis serial number, 52, 110, 117
- codd, 34
- commands
 - addboard, 67, 82
 - addcodlicense, 126
 - addtag, 67
 - cancelcmdsync, 189
 - console, 8, 9, 165
 - deleteboard, 70, 84
 - deletecodlicense, 126
 - disablecomponent, 149
 - enablecomponent, 150
 - flashupdate, 81
 - initcmdsync, 188, 190
 - moveboard, 71, 86
 - poweroff, 143
 - poweron, 143
 - reset, 146
 - resetsc, 155
 - runcmdsync, 189
 - savecmdsync, 188
 - setbus, 99
 - setcsn, 53
 - setdate, 76

- setdefaults, 72, 88
- setfailover, 184
- setkeyswitch, 91, 94, 98, 139
- setobpparams, 94, 95
- setupplatform, 65, 128
- showboards, 73, 89, 170
- showbus, 100
- showcmdsync, 189, 190
- showcodlicense, 127
- showcodusage, 133
- showdate, 76
- showdevices, 90, 170
- showenvironment, 170
- showfailover, 185
- showkeyswitch, 175
- showlogs, 104, 118, 140, 200
- showobpparams, 94, 171
- showplatform, 74, 89, 140, 171
- showxirstate, 173
- smsbackup, 217
- smsconfig, 221
- smsconnectsc, 11
- smsrestore, 218
- smsversion, 219
- testemail, 114

component health status, 104, 106

console, 8, 9

control board, 5

D

- daemons, 30
 - codd, 34
 - dca, 35
 - dsmd, 36
 - dxs, 37
 - efhd, 38
 - elad, 39
 - erd, 40
 - esmd, 40
 - fomd, 41
 - frad, 42
 - hwad, 43
 - kmd, 45
 - man, 48
 - mld, 49
 - osd, 50

- pcd, 51
- ssd, 54
- tmd, 58
- wcapp, 34

dca, 35

DCU, 3, 4, 62, 63

- assignment, 63

Degraded Configuration Preferences, 99

deleteboard, 70, 84

deletecodlicense, 126

diagnosis engines, 101, 110

disablecomponent, 149

domain configurable units

- DCU, 3, 4

Domain Configuration Units, 62

domain configuration units, 63

domain console, 165

domains, 1

- addtag, 67
- automatic restoration, 104
- console, 165
- hardware errors, 102, 104

dsmd, 36

dual control boards, 5

dxs, 37

dynamic reconfiguration

- global automatic, 64

dynamic system domains, 1

E

- efhd, 38
- elad, 39
- email event notification, 103, 107
 - email control file, 108, 111
 - email template, 108, 109
 - testing, 114
- enablecomponent, 150
- environment variables
 - SMSETC, 60
 - SMSLOGGER, 60
 - SMSOPT, 60
 - SMSVAR, 60
- erd, 40
- esmd, 40

event
 classes, 110
 code, 117
 codes, 110
 error reports, 118
 list of events, 118
events
 log, 118

F

files
 ntp.conf, 78
fomd, 41
frad, 42

G

global automatic DR, 64

H

hotspares, 124
hwad, 43

I

initcmdsycn, 188, 190

K

kmd, 45

L

logs
 event, 104, 118
 file maintenance, 200
 information types, 201
 log file management, 204
 message, 166, 199

M

man, 48
messages
 event, 117
 logging, 166, 199
mld, 49
moveboard, 71, 86

N

naming domains
 command line, 67
network interface card, 160
network time protocol daemon
 configuring, 78
NIC, 160
ntpd
 configuring, 78
NVRAM, 94

O

OpenBoot PROM (OBP), 92
osd, 50

P

pcd, 51
POST
 hardware failures, 106
poweroff, 143
poweron, 143

R

removing domains
 command line, 70, 71, 84, 86
reset, 146
resetsc, 155
runcmdsync, 189

S

- savecmdsycn, 188
- setbus, 99
- setcsn, 53
- setdate, 76
- setdefaults, 72, 88
- setfailover, 184
- setkeyswitch, 91, 94, 98, 139
- setobpparams, 94
- setupplatform, 65, 128
- showboards, 73, 89, 170
- showbus, 100
- showcmdsycn, 189, 190
- showcodlicense, 127
- showcodusage, 133
- showdate, 76
- showdevices, 90, 170
- showenvironment, 170
- showfailover, 185
- showkeyswitch, 175
- showlogs, 104, 118, 140, 200
- showobpparams, 94, 171
- showplatform, 74, 89, 140, 171
- showxirstate, 173
- SMS
 - daemons, 30
 - features, 3, 4
- SMS daemons, 30
- smsbackup, 217
- smsconfig, 221
- smsconnectsc, 11
- SMSETC, 60
- SMSLOGGER, 60
- SMSOPT, 60
- smsrestore, 218
- SMSVAR, 60
- smsversion, 219
- solaris heartbeat, 173
- Solaris operating environment, 105
- SRS Net Connect, 103
- ssd, 54
- Static Versus Dynamic Domain Configuration, 63
- status of domains

- domain status, 74, 89

- Sun Management Center, 103
- system controller, 1

T

- testemail, 114
- tilde usage, 10
- tmd, 58
- To Set Up the ACL, 65

W

- wcapp, 34

X

- xntpd
 - configuring, 78